

27

HANDBOOK
OF THE
**B.L. 6-INCH 26-CWT. MARK I
HOWITZER ON MARK I TRAVELLING
CARRIAGE.**
(LAND SERVICE.)

1919.



LONDON:
PUBLISHED BY HIS MAJESTY'S STATIONERY OFFICE.

To be purchased through any Bookseller or directly from
H.M. STATIONERY OFFICE at the following addresses:
IMPERIAL HOUSE, KINGSWAY, LONDON, W.C. 2, and 28, ABINGDON STREET, LONDON, S.W. 1.
87, PRINCE STREET, MANCHESTER; 1, ST. ANDREW'S CRESCENT, CARDIFF;
23, FORTH STREET, EDINBURGH;
or from E. PONSONBY, LTD., 116, GRAFTON STREET, DUBLIN.

1920.

Price 3s. Net.

1355.04
W19

MILITARY BOOKS

Published by



Authority.

LONDON:

PUBLISHED BY HIS MAJESTY'S STATIONERY OFFICE.

To be purchased through any Bookseller or directly from
H.M. STATIONERY OFFICE at the following addresses:
IMPERIAL HOUSE, KINGSWAY, LONDON, W.C.2, and 28, ABINGDON STREET, LONDON, S.W.1;
37, PETER STREET, MANCHESTER; 1, ST. ANDREW'S CRESCENT, CARDIFF;
23, FORTH STREET, EDINBURGH;
or from E. PONSONBY, LTD., 116, GRAFTON STREET, DUBLIN.

(The prices in brackets are those at which the books are obtainable, post free, by Officers, Non-Commissioned Officers, and Men, in the manner prescribed by Appendix XXIII of the King's Regulations and Orders for the Army, 1912. Applications should be made on Army Form L.1372, and addressed to the Secretary, War Office, S.W.1.)

- ABYSSINIA.** Expedition to. 2 vols. and maps. 1870. Half Morocco, £5 5s. Cloth, £4 4s.
- ACCOUNTS. ARMY.** See FINANCIAL INSTRUCTIONS.
- AFRICA.** Continent of. Geology of. Notes on. 1906. 3s. (2s. 4d.)
- AIRCRAFT WITH ARTILLERY.** Co-operation of. 1920. 1s. (10d.)
- ALLOWANCES. ARMY.** Regulations. 1914. (Reprinted 1918). 9d. (9d.)
See also FIELD ALLOWANCE and PAY OF OFFICERS and SEPARATION ALLOWANCE.
- AMHARIC LANGUAGE.** Short Manual of the. With Vocabulary. 1909. 5s. (3s. 6d.)
- ANIMAL MANAGEMENT.** 1908. (Reprinted 1918). 2s. (1s. 9d.)
- ANIMAL MANAGEMENT, &c.** Catechism of. 1d. (1d.)
See also HORSES.
- ARABIC GRAMMAR.** Two parts. 1887. (Sold to Officers only). 10s. (10s. 10d.)
- ARMOURERS.** Instructions for:—
Care, repair, browning, &c. of Small Arms, Machine Guns, "Parapet" Carriages, and for the care of Bicycles 1912. (Reprinted, with Amendments, 1916). 2s. 6d. (2s. 1d.)
Addendum, Jan. 1918. Care and repair of Rifles, Magazine, .303-inch pattern. 1914. (In the press)
- ARMY LIST.** The Monthly. Officers on the Active List. (Publication was suspended during the War):—
Jan. 1919, and after. Each, 5s. (4s. 1d.)
Quarterly Supplement. Officers Retired from the Active List; Victoria Cross; Orders of Knighthood; Foreign Orders; Soldiers' Balances Undisposed of; &c. &c. Jan. 1919, and after. 1s. (1s.)
- ARMY LIST.** The Quarterly (not issued in October, 1914). Each 15s. (10s. 11d.)
- ARMY ORDERS.** Monthly. Each 3d. (3d.)
- ARMY ORDERS.** Covers for. 9d. (9d.)
- ARMY REVIEW.** Quarterly. July 1911 to Oct. 1914. (Vol. I, Nos. 1 and 2, out of print). 1s. (Up to July 1914, 1s.; Oct. 1914, 11d.)
(Subsequent publication suspended)
- ARMY SERVICE CORPS.** See SERVICE.
- ARTIFICERS.** Military. Handbook. 10th Edition. 1915. 9d. (9d.)
- ARTILLERY AT THE PICARDY MANŒUVRES** in 1910. Translated from the French. 2s. 6d. (2s.)
- ARTILLERY, Royal:**—
Rangefinders. *See that item.*
Standing Orders for:—
Lieut.-Colonel's Command, R.G.A. (Coast and Siege). 1d. (1d.)
Training:—
Coast. Vol. 1. (In the press)
Field. 1914. (Reprinted 1918). 1s. (11d.)
Ditto. Examples of Ranging. To supplement those given in Sec. 227. 2d. (2d.)
Garrison.—
Vol. I. 1914. 6d. (6d.)
Vol. II. (Siege). 1911. (Reprinted, with Amendments, 1914). 9d. (8d.)
Vol. III. 1911. (Reprinted, with Amendments, 1914). 1s. (11d.)
- ARTILLERY COLLEGE.** Reports upon the 14th to 18th Senior Classes. Each 1s. (9d.) *See also ORDNANCE COLLEGE.*

MILITARY BOOKS, published by Authority—continued.

(As to prices in brackets, see top of page 2.)

ARTILLERY INSTRUMENTS:—

- Handbook of. 1914. 1s. 6d. (1s. 4d.)
Ditto. Amendments. 1d. (1d.)
Ditto. Addendum to. 2d. (2d.)
Ditto. Appendix, Dec. 1916 (Periscopes, &c.); and Amendments to p. 111 of the Handbook. *With plates.* 1d. (1d.)

ARTILLERY MUSEUM in the Rotunda, Woolwich. Official Catalogue. 1906. (Sold at the Rotunda. 1s. 6d.)

ARTILLERY AND RIFLE RANGES ACT, 1885, and MILITARY LANDS ACTS, 1892 to 1903. Byelaws under:—

- Aldeburgh, 1896; Ash (Aldershot Camp), 1887; Finborough, 1901; Hythe, 1894; Inchkeith Battery, 1896; Kinghornness, 1896; Landguard, 1887; Lydd—Dungeness, 1895; Middlewick, 1890; Millbrook, 1888; Orchard Portman, 1896; Scarborough, 1902; Scraps Gate, 1886; Shoeburyness, 1895; Southwold, 1896; Strensall, 1900; Wash, 1891; Whitelaven Battery (Cumberland), 1896. Each 1d. (1d.)

Purfleet, 1911. 1s. (9d.)

Salisbury Plain, 1900. 4d. (4d.)

ARTILLERY STORE ACCOUNTS AND THE CARE AND PRESERVATION OF EQUIPMENT OF ROYAL ARTILLERY, HORSE, FIELD, AND HEAVY BATTERIES. Notes on. Sept. 1914. 6d. (5d.)

ASSISTANCE OF OFFICERS AND MEN AND THEIR DEPENDANTS.

Funds, Associations, Societies, &c., for the. 1920. 2d. (2d.)

AUSTRIA. CAMPAIGN OF 1866 AGAINST. See GERMANY.

BARRACKS. Care of. Instruction in. 1901. 9d. (7d.)

BASHFORTH CHRONOGRAPH. Experiments with, to determine the resistance of the air to the motion of projectiles. Report on. 1870. 1s. (9d.)

BERMUDA MILITIA ARTILLERY. Regulations, 1914. 9d. (7d.)

BICYCLES. Military. Handbook on. 1911. (Reprinted, with Amendments, 1914.) (Reprinted 1916.) 1d. (1d.)

BOUNTY TO SOLDIERS. See FIELD ALLOWANCE.

BRITISH MINOR EXPEDITIONS, 1746 to 1814. 1884. 2s. 6d. (1s. 11d.)

CADET LIST.

} See TERRITORIAL FORCE.

CADET UNITS.

CAPE OF GOOD HOPE RECONNAISSANCE SURVEY, 1903-1911.

Report on the. 1s. 6d. (1s. 1d.)

CASUALTY LISTS, WEEKLY, WAR OFFICE AND AIR MINISTRY.

No. 1, Aug. 7, 1917, to No. 83, March 4, 1919. Each 8d. (3d.)

CAVALRY. Technical Operations; Cavalry in an Army; Cavalry in Battle. Translated from the French of Captain Loir, XX Army Corps Staff. With a Preface by General Langlois. *With Maps.* 3s. 6d. (2s. 9d.)

CAVALRY OF THE LINE. PEACE ORGANIZATION OF THE; and Arrangements for Mobilization consequent on the establishment of Cavalry Depôts. (Special A.O., July 19, 1909). 1d. (1d.)

CAVALRY SCHOOL, NETHERAVON. Standing Orders. 1911. 2d. (2d.)

CAVALRY TRAINING. 1912. (Reprinted, with Amendments, 1915). 1s. (11d.)

See also ITALIAN CAVALRY.

CEREMONIAL. 1912. (Reprinted 1919). 6d. (6d.)

Do. Provisional Amendments, June 1914. (*With Plates and Key.*) (Reprinted 1919) 2d. (3d.)

CHEMISTRY. PRACTICAL. Quantitative and Qualitative. A Course of. 1914. 5s. (3s. 8d.)

CHEMISTS OF THE RESEARCH DEPARTMENT. Rules and Regulations specially relating to. 1913. 1d. (1d.)

CHIROPODY. Manual of. 2d. (2d.)

CLOTHING AND NECESSARIES (including Materials). Priced Vocabulary of. 1915. Provisional. 1s. (11d.) (New edition in the press)

Ditto. Amendments, Jan., April, Aug., Nov. 1916; Feb., April, Dec. 1917; March, Nov. 1918, Jan., Nov. 1919. Jan., 1920. Each 1d. (1d.)

CLOTHING Regulations:—

Part I. Regular Forces (excluding the Special Reserve). 1914. 6d. (6d.)

Part II. Special Reserve. 1914. 3d. (3d.)

COLCHESTER GARRISON. Standing Orders. 1913. 9d. (7d.)

COMMANDS, Military, and Staff in the United Kingdom. Reorganization of. (Special A.O., Jan. 6, 1905, with alterations to date. Issued with Special A.O., Nov. 11, 1907.) 3d. (3d.)

COMPANY TRAINING. Notes on. For the use of the Special Reserve, Territorial Force, and newly-raised Units of the Regular Army. Sept. 1914. 1d. (1d.)

CONSTITUTION. The German. (Edition without Notes.) 1920. 6d. (6d.)

COOKING AND DIETARY. Military. Manual of. 1918. 6d. (6d.)

COOKING. Military. Manual of. 6d. (5d.)

CO-ORDINATION OF VOLUNTARY EFFORT resulting from the formation of the D.G.V.O. Department. A National Scheme of:—

Appendices III. and IV. A Detailed Report of the Work of the Recognized Associations. 1920. 5s. (3s. 7d.)

(The Report of the Director-General, with Appendices I. and II., was published as [Cmd. 173] of Session. 1919. Price 2d. (2d.)

MILITARY BOOKS, published by Authority—continued.

(As to prices in brackets, see top of page 2.)

- COST ACCOUNTING SCHEME FOR 1919-20.** Provisional Instructions relating to. Part I. For the guidance of Staff, Regimental and Departmental Officers at Home. 3*d.* (3*d.*)
- CREWS OF WAR DEPARTMENT VESSELS AND BOATS AT HOME STATIONS.** Regulations for the Appointment, Pay, and Promotion of. 1911. 2*d.* (2*d.*)
- CYCLIST TRAINING.** 1917. Provisional. 6*d.* (5*d.*); Amendments, Aug. 1918. 1*d.* (1*d.*)
- DEMobilIZATION. ARMY.** Regulations:—
- Part I. With Diagram showing Method of Dispersal; and Map of Dispersal Stations and Areas in the United Kingdom. 1*s.* 6*d.* (1*s.* 5*d.*)
- Part II. With Plan of Hutment Lines showing suggested Appropriation of Buildings for use as a Dispersal Station; and Map of Dispersal Stations and Areas in the United Kingdom. 6*d.* (6*d.*)
- Part III. (In the press)
- Do. Chap. XXIV. Labour Units. 2*d.* (2*d.*)
- Do. Chap. XXV. Part I. Dispersal of Officers of the Army Chaplain's Department. 1*d.* (1*d.*)
- Do. Chap. XXV. Part II. Ordnance Services. 2*d.* (2*d.*)
- Do. Chap. XXVI. Q.M.A.A.C. 2*d.* (2*d.*)
- Do. Chap. XXVII. Animals. 3*d.* (3*d.*)
- Do. Chap. XXXII. The Volunteer Force. 2*d.* (2*d.*)
- Do. Chap. XXXIII. British West Indies. Contingents. 2*d.* (2*d.*)
- Addenda to Chap. V. Special Registration. 1*d.* (1*d.*)
- Amendments:—
- Nos. 3 to 24. Each 1*d.* (1*d.*)
- To Parts I. and II. 1*d.* (1*d.*)
- DESPATCHES.** See WAR OF 1914-18.
- DISABLED AND DISCHARGED SOLDIERS IN FRANCE.** Training and Treatment of. Report by Sir Henry Norman, Bart., M.P., Liaison Officer of the Ministry of Munitions to the French Ministry of Inventions. 4*d.* (4*d.*)
- DISEASES, MEDICAL, IN THE TROPICAL AND SUB-TROPICAL WAR AREAS.** Memoranda on. 1919. With Plates, Diagrams, Text-figures, and Index. 2*s.* 6*d.* (2*s.*)
- DRAINAGE MANUAL.** For the use of Royal Engineer Officers, and other persons, employed on the Construction and Maintenance of Drainage Works in connection with War Department Buildings in the United Kingdom or in similar climates. Revised Edition. 1907. (Reprinted 1915). 6*s.* (4*s.* 4*d.*)
- DRAWING PLATES.** Military:—
- Attack of Dufor's Countermines or 2nd plate of Mines; Carnot's First System; Detached Forts; Concealed Defences, 1, 2, 3, 4; Printing Plate, A, B, C, &c.; Detail Plate, No. 1; Do., No. 2; Neighbourhood of Woolwich; Village and Surrounding Ground. Each 2*d.* (2*d.*)
- Attack of Fortress—Preliminary Operations; Do., Distant Attack; Do., Close Attack; Neighbourhood of Metz. Each 3*d.* (3*d.*)
- Neighbourhood of Woolwich. Southern Side. 1*s.* 6*d.* (1*s.* 1*d.*)
- Woods and Villages. 6 plates. Each 6*d.* (5*d.*)
- DYNAMICS.** Notes on. See ORDNANCE COLLEGE.
- EDUCATIONAL TRAINING.** Part I. General Principles. (In the press)
- EGYPT. BRITISH FORCE IN.** Standing Orders for the. 1912. 1*s.* (10*d.*)
- EGYPT. CAMPAIGN OF 1882 IN.** Military History. With Case of Maps. Condensed Edition. 1908. 3*s.* 6*d.* (2*s.* 8*d.*)
- EGYPTIAN EXPEDITIONARY FORCE.** A brief record of the Advance of the 1919. 6*s.* (4*s.* 6*d.*)
- ELECTRICAL COMMUNICATIONS, FIXED.** Instructions as to. 1912 (Reprinted, with Amendments, 1916). 4*d.* (4*d.*)
- ELECTRICITY.** Notes on. 1915. 1*s.* (11*d.*) (Under revision)
- ELECTRIC LIGHT AND POWER** of the German Army. Notes on. 1920. 1*s.* 6*d.* (1*s.* 2*d.*)
- ELECTRIC LIGHT APPARATUS, DEFENCE.** Instructions for the Working of. 1915. 1*d.* (1*d.*)
- ENCOUNTER, THE BATTLE OF.** By Hans von Kieseling. Part I. Practical. Translated. 1*s.* 6*d.* (1*s.* 3*d.*)
- ENERGY EXPENDITURE** of the Infantry Recruit in Training. The. 1920. 3*s.* (2*s.* 2*d.*)
- ENGINEER SERVICES** Regulations. Peace:—
- Part I. 1910. (Reprinted, with Amendments published up to May 1, 1915) 1*s.* (11*d.*)
- Part II. 1911. Technical Treatises. (Reprinted, with Amendments to May 1, 1915). 9*d.* (8*d.*)
- ENGINEER TRAINING.** 1912. (Reprinted, with Amendments, 1914). 6*d.* (6*d.*)
- ENGINEERING.** Field. Manual of. 1911. 9*d.* (9*d.*)
- ENGINEERING.** Military:—
- Part I. Field Defences. 1908. 1*s.* 6*d.* (1*s.* 3*d.*)
- Part II. Attack and Defence of Fortresses. 1910. 9*d.* (8*d.*)
- Part III*a.* Military Bridging—General Principles and Materials. 1913. 1*s.* (11*d.*)
- Ditto. Ditto.—Ditto. Index to. 1*d.* (1*d.*)

MILITARY BOOKS, published by Authority—continued.

(As to prices in brackets, see top of page 2.)

Engineering. Military—continued.

- Part IIIb. Military Bridging—Bridges. 1914. (Reprinted 1918). 2s. (1s. 8d.)
 Part IV. Mining and Demolitions. 1910. (Reprinted, 1915, with Amendments to 1912 inclusive). 1s. (11d.)
 Part V. Miscellaneous. 1914. 1s. (11d.)
 Part VI. Military Railways. 1899. (Out of print)

ENTRANCE. ARMY. Regulations:—

- R.M. Academy. Admission to, and for First Appointments therefrom to the Royal Artillery and Royal Engineers. (Under revision)
 R.M. College. Admission to, and for First Appointments therefrom to the Regular Army. (Under revision)
 Military Forces of the Self-governing Dominions and Crown Colonies. Officers of the. 1912. 1d. (1d.)
 Militia and Imperial Yeomanry. Officers of. 1907. 1d. (1d.)
 Special Reserve of Officers, Malta Militia, Bermuda Militia, Channel Islands Militia and Territorial Force. Officers of the. 1912. 1d. (1d.) (Issue suspended)
 University Candidates. Provisional. 1920. 1d. (1d.)
 Warrant Officers and N.C.O. of the Regular Army. Combatant Commissions as Second Lieutenants. 1914. Provisional. 1d. (1d.)
 See also MEDICAL CORPS.

EQUIPMENT. INFANTRY. Pattern 1908 Web. 1913. 2d. (2d.)

See also VALISE EQUIPMENT.

EQUIPMENT Regulations:—

- Part 1. 1912. (Reprinted, with Amendments published in Army Orders up to Aug. 31, 1914). 1s. (11d.)
 Part 2. Details—

Secs.	Secs.
I. Infantry (Regular Army). 1913. (Reprinted, with Amendments published in Army Orders up to Dec. 31, 1915). 6d. (5d.)	Xl. Signal Company (South Africa). (Regular Army). 1912. 2d. (2d.)
Ia. Mounted Infantry. 1912. 6d. (5d.)	Xm. Bridging Train (Regular Army). 1912. 2d. (2d.)
II. Cavalry (Regular Army). 1914. 3d. (3d.)	Xn. Field Squadron (Regular Army). 1914. 2d. (2d.)
III. Army Service Corps (Regular Army). 1913. (Reprinted, with Amendments published in Army Orders up to Dec. 31, 1915). 6d. (6d.)	XIa. Horse Artillery. Q.F. 13-pr. (Regular Army). 1913. 8d. (8d.)
V. Royal Army Medical Corps (Regular Army). 1914. 2d. (2d.)	XIb. Field Artillery. Q.F. 18-pr. (Regular Army). 1914. 9d. (8d.)
VI-IX. R.M. Academy; R.M. and Staff Colleges; Garrison Staff and Schools of Instruction; Military Prisons, Detention Barracks and Military Provost Staff Corps. (Regular Army.) 1914. 2d. (2d.)	XIc. Field Artillery. Q.F. 4-5-in. Howitzer. (Regular Army.) 1913. (Reprinted, with Amendments up to Aug. 1, 1914). 9d. (8d.)
Xa. Engineer. General. Fortress, Survey, Railway, and Depot Units. Peace and War. (Regular Army.) 1914. 2d. (2d.)	XId. Reserve Brigades with Q.F. 18-pr. Equipment, Horse and Field Artillery, Staff and Depôts, Riding Establishment, School of Gunnery (Horse and Field), and Mounted Band. (Regular Army.) 1914. 6d. (6d.)
Xb. Field Troop (Regular Army). 1912. 2d. (2d.)	XIe. Mountain Artillery with B.L. 2-75-in. Equipment. Mountain Battery and Ammunition Column. Mule Transport. (Regular Army.) 1914. Provisional. 6d. (5d.)
Xc. Field Company (Regular Army). 1914. 2d. (2d.)	XIIa. Royal Garrison Artillery (Regular Army). 1914. 2s. 6d. (1s. 11d.)
Xd. Divisional Signal Company (Regular Army). 1914. 2d. (2d.)	XIIb. Royal Garrison Artillery, Siege Artillery, Movable Armament, and Machine Guns in Armaments. 1913. 1s. (10d.)
Xe. Signal Company (Wireless) (Regular Army). 1912. 2d. (2d.)	XV. Camel Corps School, Egypt (Regular Army.) 1914. 2d. (2d.)
Xf. Headquarters Signal Units (Regular Army). 1914. 2d. (2d.)	XVI. Special Reserve. 1913. 4d. (4d.)
Xg. Signal Company (Cable) (Regular Army). 1912. 2d. (2d.)	XVII. Officers Training Corps. 1919. 1d. (1d.)
Xh. Signal Squadron (Regular Army). 1914. 2d. (2d.)	Practice Batteries and Drill Guns (Fixed Mountings) of the Royal Garrison Artillery. (Part 2, Secs. XIIa. and XVI., and Part 3.) 1909. 1s. 6d. (1s. 2d.)
Xj. Signal Troop with Cavalry Brigade (Regular Army). 1912. 2d. (2d.)	
Xk. Signal Troop with a Cavalry Brigade not allotted to a Cavalry Division (Regular Army). 1914. 2d. (2d.)	

MILITARY BOOKS, published by Authority—continued.

(As to prices in brackets, see top of page 2.)

Equipment Regulations—continued

- Part 3. Territorial Force. 1914. 6d. (6d.)
 Ditto. Details:—
 Sec. IX. Artillery. 1912. (Out of print)
 Ditto. Amendments. April 1912; Feb. 1914. Each 1d. (1d.)
 Sec. X. Engineer. 1912. 3d. (3d.)
 Amendments to Part 1. Feb. 1916. 1d. (1d.)
 Amendments to Part 2. Feb., July (two issues), Aug. 1914. Each 1d. (1d.)
 Amendments to Parts 1, 2, and 3. Nov. 1913. 1d. (1d.)
 Amendments to Parts 1, 2, and 3. March, July 1913; April, Aug. 1914.
 Each 2d. (2d.)
 Amendments to Part 2, Sec. XVII. Feb. 1920. 1d. (1d.)

EXAMINATION PAPERS. (All published papers of which the dates are omitted are out of print):—

- Qualifying Certificates. Sept. 1905; March 1906; Sept. 1909; March, Sept. 1910; March, Sept. 1911; March 1912. Each 6d. (5d.)
 Entrance: R.M. Academy, R.M. College, Qualifying Test for Commissions. Nov.-Dec. 1913. 1s. (11d.)
 Entrance: R.M. Academy; R.M. College; Indian Army College, Wellington. Supplementary First Appointments in the Royal Marines. Appointments in the Indian Police Force. Appointments in the Police Force of Ceylon. Cadetships in the Royal Navy (Special Entry). June-July 1915. 1s. (11d.)
 Entrance: R.M. Academy; R.M. College; Indian Army College, Wellington. Nov.-Dec. 1915. 1s. (10d.)
 Entrance: R.M. Academy; R.M. College; Indian Army College, Wellington. Supplementary First Appointments in the Royal Marines. Cadetships in the Royal Navy (Special Entry). June-July 1916. 1s. (1s.)
 Entrance: R.M. Academy; R.M. College; Indian Army College, Quetta. Nov. 1916. 1s. (1s.)
 Entrance: R.M. Academy; R.M. College; Indian Army College, Quetta. Cadetships in the Royal Navy (Special Entry). March 1918. 6d. (6d.)
 Entrance: R.M. Academy; R.M. College; Royal Air Force. Nov. 1915. 2s. (1s. 7d.)
 Freehand Drawing at the Army Entrance Examination of Nov. 1913. Specimen Paper to illustrate the kind of questions that will be set in. 6d. (5d.)
 R.M. Academy, Fourth Class; R.M. College, Fourth, Third, and Second Divisions, July, Dec. 1904; June 1905. Each 1s.
 R.M. Academy, Fourth Class; R.M. College, Senior Division. Dec. 1905; June, Dec. 1906; July, Dec. 1907. Each 1s.
 Staff College. Admission. Aug. 1909; July 1911; June-July 1912; June-July 1913. Each 1s. (6d.)
 Officers for Promotion. Dec. 1912; Dec. 1913; April 1914. Each 1s. (6d.)
 Militia, Imperial Yeomanry, and University Candidates. March, 1904; Sept. 1905; Oct. 1906. Each 1s.
 Special Reserve, Militia, Territorial Force, and University Candidates. Oct. 1911; March, Oct. 1912; March, Oct. 1913. Each 1s. (6d.)
 Special Reserve, Militia, Territorial Force, Non-Commissioned Officers, and University Candidates. March 1914. 1s. (6d.)
 Officers Training Corps:—
 Cadets of the Senior Division. Certificate A. Dec. 1908. 6d. (5d.)
 Cadets of the Junior and Senior Divisions. Certificates A and B. Spring of 1909; May, Nov. 1911; March, Nov. 1912; March 1914. Each 6d. (6d.)
 Foreign Languages. Modern. June 1919. 1s. (11d.)

FAMILY ALLOWANCE. See PAY FOR SOLDIERS and SEPARATION ALLOWANCE.

FIELD ALLOWANCE to the Commander of an Army and to the Commander of an Army Corps or Group of Divisions; **Promotion of Lieutenants** of the Army Veterinary Corps, Special Reserve, and Territorial Force; **Bounty to Soldiers.** Special Army Order, June 20, 1916. 1d. (1d.)

FIELD ALMANAC. 1918. 1d. (1d.)

FIELD SERVICE MANUALS:—

- Ammunition Column, Divisional. New Armies. 1915. 3d. (3d.)
 Artillery. Heavy (B.L. 60-pr.) Battery and Ammunition Column. Expeditionary Force. 1916. 3d. (3d.)
 Ditto. Horse. Brigade. 13-pr. (Q.F. 1908. 3d. (3d.)
 Cavalry Regiment. Expeditionary Force. 1913. 3d. (3d.)
 Engineers. Bridging Train. Expeditionary Force. 1915. 3d. (3d.)
 Ditto. Field Company. Expeditionary Force. 1915. 3d. (3d.)
 Ditto. Field Squadron. Expeditionary Force. 1914. 3d. (3d.)
 Ditto. Works Company. Expeditionary Force. 1910. 3d. (3d.)
 Headquarters Units. Expeditionary Force. 1911. 3d. (3d.)
 Infantry Battalion. Expeditionary Force. 1914. 3d. (3d.)
 Infantry (Mounted) Battalion. Expeditionary Force. 1914. 3d. (3d.)
 Medical Service, Army. Expeditionary Force. 1914. 3d. (3d.)
 Signal Service. Signal Company (Air-Line). Expeditionary Force. 1913. 3d. (3d.)
 Ditto. Ditto. (Cable). Expeditionary Force. 1913. 3d. (3d.)
 Ditto. Ditto. (Divisional) Expeditionary Force. 1915. 3d. (3d.)

MILITARY BOOKS, published by Authority—continued.

(As to prices in brackets, see top of page 2.)

FIELD SERVICE POCKET BOOK. 1914. (Reprinted, with Amendments, 1916). 1s. (11*d.*); Addendum No. 1. Shortened Form of Service for the Burial of the Dead. 1*d.* (1*d.*)

FIELD SERVICE REGULATIONS :—

Part I. Operations. 1909. (Reprinted, with Amendments, 1914). 6*d.* (6*d.*)
Part II. Organization and Administration. 1909. (Reprinted, with Amendments to Oct. 1914). 1s. (10*d.*)

Ditto. Amendments, April 1915. 1*d.* (1*d.*)

Ditto. Addendum, Jan. 1917, for the guidance of Troops operating in France and Belgium. Duties and Responsibilities of the Quartermaster-General, the Director-General of Transportation, and the General Officer Commanding Lines of Communication Area. 1*d.* (1*d.*)

Ditto. Additions and Corrections, March 1917. Duties and Responsibilities of the Engineer-in-Chief, and of Chief Engineers; &c. 1*d.* (1*d.*)

FINANCIAL INSTRUCTIONS IN RELATION TO ARMY ACCOUNTS.

1910. (Reprinted, with Amendments to Oct. 1, 1917). 6*d.* (5*d.*)

FIRE MANUAL. ARMY. 1917. 2*d.* (3*d.*)

FLYING CORPS. ROYAL. Training Manual:—

Part I. 1914. Provisional. 1s. (10*d.*)

Ditto. Amendments. Jan. 1916. 1*d.* (1*d.*)

FOREIGN LANGUAGES. STUDY OF. Regulations. 1919. 2*d.* (2*d.*)

FOREIGN PRESS. Supplements to the Daily Review of the :—

Economic. Fortnightly, commencing with that of Aug. 20, 1918, to Aug. 12, 1919. Each 6*d.* (6*d.*)

Medical (Compiled by the Medical Research Committee). Monthly, commencing with that of June 1918 to April 1918. Each 1s. (10*d.*)

Political. Vol. VII. Weekly, Aug. 9, 1919.

Sec. I. No. 1. Central Europe. 6*d.* (6*d.*) (Out of print)

Sec. II. No. 1. East and North-East Europe. 6*d.* (6*d.*) (Out of print)

Sec. IV. No. 1. Western Europe. 6*d.* (6*d.*) (Out of print)

Sec. V. No. 1. America and the Pacific. 6*d.* (6*d.*) (Out of print)

Reconstruction. Fortnightly, commencing with that of Aug. 13, 1918, to July 30, 1919. Each 6*d.* (6*d.*)

Reconstruction. Fortnightly. Aug. 13, 1918, to July 30, 1919. Each 6*d.* (6*d.*)

Technical. Fortnightly, commencing with that of May 28, 1918, to Aug. 4, 1919. Each 6*d.* (6*d.*)

Index to the Economic and Reconstruction Supplements May to Nov. 1918. 1s. (11*d.*)

Index to the Medical Supplement. Vol. I., Jan. to Dec. 1918. 1s. (10*d.*)

Ditto Ditto Vol. II., Jan.-April, 1919. 1s. (10*d.*)

Index to the Technical Supplement. Vol. I., July to Dec. 1918. 6*d.* (6*d.*)

FORTIFICATION. PERMANENT. For the Imperial Military Training Establishments and for the Instruction of Officers of all Arms of the Austro-Hungarian Army. 7th Edition. Translated. 4s. (2s. 11*d.*)

FRANCE. DISABLED AND DISCHARGED SOLDIERS IN. See DISABLED.

FRANCO-GERMAN WAR, 1870-71. Translated from the German Official Account:—

First Part—History of the War to the Downfall of the Empire—

Vol. 1 (Secs. 1 to 5). Outbreak of Hostilities to Battle of Gravelotte.

Vol. 2 (Secs. 6 to 9). Battle of Gravelotte to Downfall of the Empire. (Out of print)

Second Part—History of the War against the Republic—

Vol. 1 (Secs. 10 to 13). Investment of Paris to Re-occupation of Orleans by the Germans. £1 6s. (18s. 6*d.*)

Vol. 2 (Secs. 14 to 18). Events in Northern France from end of Nov. in North-west from beginning of Dec. Siege of Paris from commencement of Dec. to the Armistice. Operations in the South-east from middle of Nov. to middle of Jan. £1 6s. (19s.)

Vol. 3 (Secs. 19 and 20). Events in South-east France from middle of Jan. to Termination of Hostilities. Rearward Communications. The Armistice. Homeward March and Occupation. Retrospect. £1 11s. 6*d.* (£1 2s. 3*d.*)

Also separately, Sections in paper covers, and Plans unmounted:—

Section.

1. Events in July. Plan. 3s. (2s. 2*d.*)

2. Events to Eve of Battles of Wörth and Spicheren. 3rd Edition. (Out of print)

3. Battles of Wörth and Spicheren. 3rd Edition. (Out of print)

4. Advance of Third Army to the Moselle, &c. 2nd Edition. (Out of print)

5. Operations near Metz on 15th, 16th, and 17th August. Battle of Vionville—Mars la Tour. 2nd Edition. (Out of print)

MILITARY BOOKS, published by Authority—continued.

(As to prices in brackets, see top of page 2.)

Franco-German War—continued.

Section.

6. Battle of Gravelotte—St. Privat. (Out of print)
7. Advance of Third Army and of Army of the Meuse against Army of Ohalons. (Out of print)
8. Battle of Sedan. (Out of print)
9. Proceedings on German Coast and before Fortresses in Alsace and Lorraine. Battle of Noisseville. General Review of War up to September. 4s. 6d. (8s. 4d.)
10. Investment of Paris. Capture of Toul and Strassburg. 6s. (4s. 6d.)
11. Events before Paris, and at other points of Theatre of War in Western France until end of October. 5s. 3d. (3s. 11d.)
12. Last Engagements with French Army of the Rhine. Occurrences after fall of Strassburg and Metz to middle of November. 4s. 6d. (3s. 5d.)
13. Occurrences on Theatre of War in Central France up to Re-occupation of Orleans by the Germans. 6s. (4s. 6d.)
14. Measures for Investment of Paris up to middle of December. 4s. (3s.)
15. Measures for Protecting the Investment of Paris and Occurrences before French Capital to commencement of 1871. 2s. 6d. (1s. 11d.)
16. Proceedings of Second Army from commencement of 1871 until the Armistice. 3s. 6d. (2s. 8d.)
17. Proceedings of First Army from commencement of 1871 until the Armistice. 3s. (2s. 3d.)
18. Occurrences on South-eastern Theatre of War up to middle of January, 1871. Events before Paris from commencement of 1871 to the Armistice. 8s. (6s.)
19. Occurrences on South-eastern Theatre of War from middle of January, 1871. Proceedings in rear of German Army and in Coast Provinces, from Nov 1870 until the Armistice. 13s. 6d. (9s. 8d.)
20. General Retrospect of War from beginning of Sept., 1870, to Cessation of Hostilities. Armistice and Peace Preliminaries. Return of German Army and Peace of Frankfurt. The Occupation. The Telegraph, Post, Supply of Ammunition, Commissariat, Hospital Service, Divine Service, Military Justice, Recruitment, and Home Garrisons. Results. 5s. (3s. 9d.)

Analytical Index. 1s. 6d. (1s. 1d.)

Plans—

4. Battle of Colombey-Neuilly. 3d. (3d.)
- 5A. Battle of Vionville—Mars la Tour. Position of Contending Forces at Noon. 3d. (3d.)
- 5B. Battle of Vionville—Mars la Tour. Position of Contending Forces from 4 to 5 p.m. 3d. (3d.)
- 9A. Battle of Sedan. Position of Contending Forces towards Noon. 3d. (3d.)
- 9B. Battle of Sedan. Position of the Germans in the afternoon shortly before the end of the struggle. 3d. (3d.)

See also SIEGE OPERATIONS.

FRENCH WORDS AND PHRASES with English Pronunciation. Short Vocabulary of. Notes on French Measures. Abbreviations and Terms used on French Maps, with English Equivalents. 1d. (1d.)

GERMAN ARMY:—

- Cavalry. Drill Regulations. 1909. 3d. (3d.)
- Electric Light and Power. Notes on. 1920. 1s. 6d. (1s. 2d.)
- Foot Artillery. Drill Regulations. Part IV. THE FIGHT. 1909. 8d. (3d.)
- Manœuvres Regulations. 1908. 3d. (3d.)

GERMANY. The Campaign of 1866 in. With 22 Plans in portfolio. 1872. (Re-printed 1907). 6s. (4s. 10d.)

Ditto. Moltke's Projects for. 1s. (10d.)

Ditto. Moltke's Correspondence during. Précis. With 4 Plans. 1s. (10d.)

GUERNSEY AND ALDERNEY ROYAL MILITIA. Regulations. With the Militia Laws relating to the Islands. Provisional. 3s. (2s. 2d.)

GUNS. Handbooks for:—

- 303-inch Hotchkiss Machine. Provisional. 6d. (5d.)
- M.L. Stokes 3-inch Trench Mortar Equipments. Land Service, 1919. (1920). 1s. 6d. (1s. 2d.)

See also MACHINE GUNS; MUSKETRY REGULATIONS, PART I.; and RIFLE, ROSS MAGAZINE.

HISTORICAL RECORDS OF THE BRITISH ARMY:—

- Horse Guards. 5s. (3s. 7d.)
- 7th Hussars. 4s. (2s. 11d.)
- Dragoon Guards, 3rd, 4th, 6th, and 7th. Each 4s. (3s.)
- Dragoons, 1st, 3rd, 7th, 14th, and 16th. Each 4s. (3s.)
- Ditto. 12th and 13th. Each 3s. (2s. 3d.)
- Marine Corps. 3s. (2s. 2d.)
- Foot, 2nd, 6th, 7th, 8th, 10th, 11th, 13th, 15th, 16th, 17th, 18th, 19th, 21st, 22nd, 36th, 39th, 46th, 53rd, 67th, 71st, 72nd, 73rd, 74th, 86th, 87th, and 92nd. Each 4s. (3s.)
- Do. 14th, 56th, 61st, 70th, and 88th. Each 3s. (2s. 3d.)

HANDBOOK
OF THE
B.L. 6-INCH 26-CWT. MARK I
HOWITZER ON MARK I TRAVELLING
CARRIAGE.
(LAND SERVICE.)

1919.



LONDON:
PUBLISHED BY HIS MAJESTY'S STATIONERY OFFICE.

To be purchased through any Bookseller or directly from
H.M. STATIONERY OFFICE at the following addresses:
IMPERIAL HOUSE, KINGSWAY, LONDON, W.C. 2, and 28, ABINGDON STREET, LONDON, S.W. 1;
37, PETER STREET, MANCHESTER; 1, ST. ANDREW'S CRESCENT, CARDIFF;
23, FORTH STREET, EDINBURGH;
or from E. PONSONBY, LTD., 116, GRAFTON STREET, DUBLIN.

1920.

Price 3s. Net.

24940



(B 14096) Wt. 43220—PP 1991 3M 4/20 H & S TS No. 1564 G.H. 28



CONTENTS.

	PAGE		PAGE
PART I.		PART V.	
HOWITZER—		CARE AND PRESERVATION OF—	
Particulars	5	Howitzer	37
Description	5	Carriages	38
Breech mechanism	6	Instructions for filling, &c.,	
Breech closing mechanism	7	of hydraulic buffer and	
Firing mechanisms	7	recuperator... ..	39
Obturation	9	Sighting	51
Instructions for removing and		List of lubricants	52
replacing breech fittings	10		
PART II.		PART VI.	
CARRIAGE—		MISCELLANEOUS STORES—	
Description	12	Apparatus, illuminating sights	53
Trail	13	Bit, vent	53
Axletree and wheels	14	Borer, vent axial	53
Brake gear	15	Box, obturator	53
Saddle	15	Brush, piassaba	53
Traversing gear... ..	16	Cap, rammer	53
Cradle	16	Compressor, air, portable	53
Quick-loading gear	17	Cover, breech	56
Cradle clamp	17	Cover, muzzle	57
Hydraulic buffer	18	Cover, rocking bar sight	57
Tanks, gravity	19	Funnel, filling cylinder	57
Cut-off gear	20	Implements, ammunition	57
Recuperator	20	Lanyards, firing... ..	58
Action of buffer and recuperator	22	Mats, gun wheel	58
Elevating gear	23	Measure, filling hydraulic buffer	58
DIMENSIONS AND WEIGHTS	24	Press, obturator, &c.	58
		Pump, liquid, portable... ..	59
PART III.		Rammer	59
SIGHTING—		Rimers, vent axial	59
Sight operating gear	25	Sling, housing draught link	59
Sight, rocking-bar	25	Sling, projectile... ..	59
Clinometer, sight	26	Stave end, No. 17	59
Carrier, No. 7 dial sight, No. 5	27	Syringe, extracting liquid	59
Sight, dial, No. 7	27	Trays, loading	59
Sight, dial, No. 1	30	Wrenches, breech mechanism... ..	60
Instructions for testing sights	31		
PART IV.		PART VII.	
LIMBER—		AMMUNITION—	
Frame	33	Table	61
Axle and wheels	33	Projectiles	62
Limber box	33	Fuzes	63
Fittings for draught	34	Adapters... ..	71
PACKING—		Gaine, No. 2	71
List of stores	35	Cartridges	71
Diagram (to face)	36	Tubes	72

CONTENTS—*continued.*

PLATES.	No. of PLATE.
Howitzer	I
Breech mechanism	II to IV
Percussion lock "P.H." and Box slide "V"	V and VI
Carriage	VII to XI
Brake gear	XII
Method of assembling girdles	XIII and XIV
Hydraulic buffer and recuperator	XV
Enlarged view of ram head, Mark III	XVI
Snifting valve	XVII
Gravity tanks and isolating valve	XVIII
Cut-off gear	XIX and XX
Method of setting cut-off gear	XXI
Pressure gauge in position	XXII
Elevating, traversing, quick-loading and sight operating gears	XXIII
Sight, rocking-bar	XXIV
Sight, dial, No. 7	XXV and XXVI
Sight, dial, No. 1	XXVII
Target, sight testing	XXVIII
Limber	XXIX
Compressor, air, portable	XXX and XXXI
Apparatus, illuminating sights, No. 1	XXXII
Projectiles.	XXXIII to XXXVIII
Fuzes	XXXIX to XLVI
Cartridge	XLVII
Tube	XLVIII

NOTE.—*This book is corrected up to June, 1919. Any alterations which may be suggested should be forwarded direct to the Chief Inspector of Armaments, Inspection Department, Royal Arsenal, Woolwich.*

HANDBOOK

OF THE

B.L. 6-inch 26-cwt. Howitzer, Mark I.

PART I.

PARTICULARS.

Material	Steel (wire construction).
Weight (including breech mechanism)	1-ton, 5-cwts. 2-qrs.
Length, total	87.55-inches.
Bore	{	Calibre	6-inches.
		Length	79.8-inches = 13.3-calibres.
		Capacity	2,365-cubic inches.
Chamber	{	Diameter	6.45-inches.
		Length	11.53-inches.
		Capacity	390-cubic inches.
Rifling	{	System	Polygroove, plain section.
		Length	65.475-inches.
		Twist	Uniform, 1 turn in 15-cals.
			
Grooves	{	Number	36.
		Width	0.349-inch.
		Depth	0.05-inch.
Obturation	Pad.
Venting...	Axial.
Firing mechanism	Martini-Netford percussion lock or P.H., percussion lock and slide box "V."

HOWITZER BODY.

(Plate I.)

The howitzer is made of steel and consists of an "A" tube, muzzle stop ring, a series of layers of steel wire, jacket, guide ring, breech ring and breech bush. Over the exterior of the "A" tube are wound a series of layers of steel wire extending from the breech end to the stop ring, which is shrunk over the "A" tube at the muzzle. The jacket is shrunk over the exterior of the "A" tube, wire and muzzle stop ring and is secured longitudinally by corresponding shoulders and by the breech bush, which is screwed into the rear end; the bush is also prepared for the reception of the breech screw. The breech ring (which is prepared for the reception of the breech mechanism and furnished on the under-side with a lug for the attachment of the body of the hydraulic buffer and recuperator of the carriage) is screwed over the jacket at the rear and is prevented from turning when in position by means of two securing screws. The guide ring is shrunk round the jacket, towards the muzzle.†

† Guide rings of existing howitzers will be secured in position by three set screws. In future manufacture the guide ring will be screwed over the jacket.

A steel stud with locking plate and keep pin for use with the connecting stud nuts of the carriage, is provided in the rear face of the lug on the breech ring. A recoil indicator consisting of a bracket with two fixing screws, plunger with keep pin and plunger spring, is attached to the guide ring on the left side and serves as a reader for the recoil scale on the cradle. A steel stop plate is secured to the front face of the lugs by two screwed rivets.

Longitudinal projections on the sides of the jacket and guide ring with gunmetal bearing strips form guides for the howitzer when in the cradle of the carriage.

Left and right side cover plates of gunmetal are provided on the howitzer connecting the front and rear guides. The bodies of the cover plates are prepared with a recess for holding lubricant and furnished with upper and lower lubricating pads with retaining plates and joint strips so arranged as to lubricate the guide ways for the howitzer in the cradle of the carriage. The cover plates are fitted to the left and right sides respectively of the howitzer body of which they form part and are secured in position by means of supporting studs in the front face of the guide projections on the jacket and securing screws in the rear face of the guide projections on the guide ring. A lubricator filling plug with loop, chain and securing screw is provided in the upper side of the cover plates.

Guide ring lengthening blocks are provided for use with howitzers having short guide rings. The lengthening blocks are of steel and are secured by screws to the rear face of the projections on the guide ring.

The chamber is cylindrical, coned at the entrance and reduced in diameter at the front end.

A plane for clinometer is prepared on the right upper side of the breech ring.

Axis lines are cut on the upper side and on the horizontal axis at the breech and muzzle ends. Fine horizontal and vertical axis lines are also cut on the breech and muzzle faces.

The actual weight of the howitzer (without breech mechanism) is engraved on the top of the breech ring and a line denoting centre of gravity (without mechanism) is cut transversely on the upper side of the jacket.

The nature, mark, register number, manufacturer's initials and year of manufacture are engraved on the upper portion of the breech face.

BREECH MECHANISM.

(Plates II to IV.)

The breech mechanism is worked by means of a lever on the right side of the breech. On pulling the lever to the rear, the breech screw is automatically unlocked and swung into the loading position. After loading, one thrust on the same lever inserts the breech screw and turns it into the locked position.

BREECH CLOSING MECHANISM.

The breech is closed by a parallel screw of the Welin type, which is divided circumferentially into 12 equal parts, four of which are plain and the remaining eight screw-threaded, thus giving a two-thirds bearing surface to the breech screw in the locked position. The screwed parts are of varying diameters, the breech opening of the howitzer being prepared in a corresponding manner. The interruptions in the howitzer are arranged to accommodate the segments of the screw of largest diameter; thus, when the screw is unlocked, these segments pass into the interruptions and the segments next smaller in diameter unlock into the spaces left vacant by the larger ones.

The interior of the screw is recessed to fit over a pintle on the front of the carrier and is bored through its centre for the reception of the axial vent.

The breech screw is supported when withdrawn by a bronze carrier hinged to the right side of the breech ring, the dead weight of the mechanism being taken on a bronze washer between the carrier and the bottom lug on the breech ring. Upon the front of the carrier is a pintle, forming a pivot for the breech screw, which is secured thereon by means of a retaining plate and an eccentric actuating pin in the rear end of the breech screw, so arranged as to admit of the breech screw being revolved through one-twelfth of a circle on the pintle in locking and unlocking.

By depressing the eccentric pin against a spring, it can be rotated through 180°, the plate being thus drawn back flush with the hole in the breech screw, for assembling or dismantling.

This arrangement also permits of the carrier being withdrawn independently of the breech screw, should the latter become fast in the breech.

A recess for a crosshead is provided in the right side of the breech screw. The crosshead is actuated by means of a crank and breech mechanism lever in the carrier, so as to revolve the screw in locking and unlocking. A roller with axis pin on the rear face of the breech screw and a cam on the breech end, are also provided, to give a turning movement to the breech screw in closing.

A control arc is provided in the carrier hinge joint of the breech ring, over which the lower end of the breech mechanism lever rides and thus prevents the breech screw rotating as the mechanism is swung into the loading position. The arc is also used as a friction brake, to control the swing-out of the breech mechanism when opening the breech at angles of elevation by slightly raising the lever and has a recess into which the lower end of the lever falls when it is slightly raised and thus retains the mechanism in the open position.

The breech mechanism lever is retained in the closed position by means of a catch in the lever, which engages a steel catch plate in the carrier.

FIRING MECHANISM.

There are two different firing mechanisms in use with these howitzers as follows:—(1) Martini-Metford percussion lock mechanism and (2) lock, percussion, "P.H." and box, slide, "V" mechanism.

(1) *Martini-Metford Percussion Lock Mechanism.**(Plates II, III and IV.)*

A steel vent bolt passes through the centre of the breech screw and the pintle on the carrier, being feathered to the latter to prevent it turning and is retained in the breech screw by means of a spiral spring and nut. Through the longitudinal axis of the vent bolt is fitted a vent bush spindle prepared with a firing channel and chambered at the rear end to suit the "tube, percussion, S.A. cartridge." The vent bush spindle is furnished at the rear end with a converted Martini-Metford percussion lock which is screwed to the vent bush spindle and prevented from turning by a securing block and keep pin and is secured in the axial vent bolt by a nut and copper washer at the front end.

A bronze safety shutter, actuated by the breech screw in locking and unlocking, is provided in the exterior of the carrier and serves to prevent the insertion of the firing peg into the lock until the breech screw is locked in the howitzer.

A retaining pin with keep pin is provided in the left side of the carrier for retaining the vent axial nut and safety shutter in position.

The No. 35 firing lanyard is attached to the loop of the firing peg and is pulled from the right side.

Method of Using Martini-Metford Converted Lock.

The "tube, percussion, S.A. cartridge" will always be inserted into the tube chamber after the breech of the howitzer is closed and the breech mechanism lever home. After inserting the tube into the tube chamber the firing peg will be placed in the hole in the lock for its reception from the right side and pushed home. The breech of the lock will then be closed by pushing the actuating lever of the lock to the front. The howitzer can then be fired by pulling out the firing peg.

The firing peg must always be inserted in the lock before closing the breech of the lock, and care must be taken to see that the peg is in position when the actuating lever is pushed forward in closing.

A certain number of Mark III axial vents have been issued with which a converted Martini-Metford lock with securing collar and rivet is screwed over the rear end of the vent bolt. These locks are described as "special." The vent bolt is prepared with a fire channel through the longitudinal axis and is chambered to suit the "tube, percussion, S.A. cartridge." A recess is formed in the outer edge of the securing collar on the lock for the reception of the retaining pin in the left side of the carrier.

The method of using the "special" lock is the same as shown above.

(2) *Lock, Percussion, "P.H." and Box, Slide, "V."**(Plates V and VI.)*

The firing mechanism with percussion lock "P.H." and slide box "V" consists of an axial vent originally provided with a vent bush spindle which is generally similar to, but not interchangeable with

the vent bush spindle belonging to the Martini-Metford percussion lock. The outer end of the vent bush spindle is chambered to suit the "tube, percussion, S.A. cartridge," and is prepared on the exterior with a screw thread for the reception of the slide box "V."

The *box, slide, "V"* consists of a steel body screwed internally to suit the outer end of the vent bush spindle and prepared for the reception of the percussion lock "P.H." In the interior of the slide box is pivoted an extractor lever, the inner end of which engages the percussion tube in the vent and having a lug on the outer end by means of which it is actuated in working the lock. A steel stop plate for the actuating lever catch of the lock is provided on the exterior and secured by two screwed rivets. The slide box is prevented from turning when in position by a securing screw.

The *percussion lock, "P.H."* consists of a steel frame with firing hole bush and furnished with a striker, striker nut, cap, main spring and rebound collars and main spring. The lock slides vertically in the slide box and is worked by means of an actuating lever with retaining catch plunger and spring pivoted on the exterior of the frame. The striker is withdrawn and the main spring compressed by a steel wedge fork on the No. 33 firing lanyard (*see* Plate V) which engages the under-side of the striker cap when placed in position and is released in firing by pulling the lanyard clear of the lock.

Original axial vents for use with vent bush spindle, slide box "V" and percussion lock "P.H." are described as Mark V and so stamped. Existing vents of earlier pattern, on conversion for use as above, are described as Mark IV*, III**, II**, I**** and I***** respectively and so stamped.

Axial vents of later manufacture, described as Mark VI, are for use with slide box "V" and percussion lock "P.H.," but without the vent bush spindle, and differ from Mark V pattern in being furnished at the outer end with a No. 4 vent head chambered to suit the "Tube, percussion, S.A. cartridge" and prepared on the exterior with a screw thread for the reception of the slide box "V." Existing vents which have been prepared for the reception of vent bush spindles will, on conversion to Mark VI pattern with No. 4 vent head, have the hole for vent bush spindle plugged and will be described as Mark V*, IV**, III***, II***, I***** and I***** respectively and so stamped. Existing vents which do not require plugging will, on conversion to Mark VI pattern, be described as Mark III^s, II^s, I*^s and I^s respectively and so stamped.

OBTURATION.

(Plate IV.)

The obturator, which is of the steep-coned type, is supported on the axial vent and is held tightly between the mushroom-shaped head of the latter and the front face of the breech screw by the spring and nut, vent axial.

The pad of Marks I and II obturators consists of asbestos worked up in mutton suet or rape oil to a proper consistency, enclosed in a strong canvas cover in the case of Mark I and wire-woven cover in the case of Mark II and pressed into shape in a hydraulic machine.

The pad is enclosed between a front copper protecting disc, around the outer edge of which is a split steel ring and a rear inner and outer steel ring, the outer one being split.

A certain number of Mark III obturators have been made which differ from Marks I and II obturators in the following particulars:—

The Mark III obturator has no front copper protecting disc, the pad being made correspondingly thicker, so as to render the obturator interchangeable with Marks I and II. The pad is made of Canadian asbestos worked up in hydrogenated whale oil, and enclosed in a wire woven cover.

Pads belonging to Mark III obturators can be used with Marks I and II obturators, but without the front copper protecting disc. Pads belonging to Marks I and II obturators are not interchangeable with Mark III obturators.

The disc, where fitted, is stamped with the word "FRONT" and the pads have the word "FRONT" stencilled on the side which corresponds with the front disc and "REAR" on that which corresponds with the inner and outer rear rings, in order that they may be correctly assembled on the vent.

If correctly assembled the whole should fit together compactly.

Thin steel adjusting discs are provided for insertion behind the rear steel rings and pad when found necessary.

Action.—When the breech screw is swung into the howitzer, the obturator enters the chamber with ease; on turning the breech screw the pad is pressed home into the coned seating of the howitzer by the travel of the screw. The bore is thus closed by the pad which is in contact with the bore all round its circumference, while the mushroom-head of the axial vent receives the force of the gas on discharge. On firing the howitzer the pressure acts on the mushroom-head of the vent and compresses the pad against the breech screw, causing it to expand. This expansion is radial to the axis and equal in every direction and is sufficient to prevent the escape of gas. On the pressure being removed elasticity comes into play and the obturator can be withdrawn from the coned seating so soon as the screw is unlocked.

For instructions regarding the fitting, testing, adjusting and treatment of obturating pads and discs, see page 57.

TO REMOVE THE BREECH FITTINGS.

Before commencing to remove the fittings the breech screw and carrier must be swung into the loading position.

MARTINI-METFORD PERCUSSION LOCK MECHANISM.

Lock, percussion, Martini-Metford.—Remove the nut and washer from the front end of vent bush spindle and withdraw the lock and vent bush spindle from the axial vent to the rear, except with Mark III vents. In the case of Mark III vents, remove the keep pin from the "pin, retaining, axial vent nut and safety shutter" and withdraw the latter clear of the recess in the securing collar on the lock. Open the lock and unscrew the latter with securing collar and remove the lock with securing collar to the rear.

“P.H.” PERCUSSION LOCK AND “V” BOX SLIDE MECHANISM.

Lock, percussion, “P.H.”—Remove the extractor axis screw from the slide box “V” and turn the actuating lever of the lock to the open position, then withdraw the lock and extractor lever from the slide box in a downward direction.

Box, slide, “V.”—Remove the securing screw and unscrew the slide box from the vent bush spindle or axial vent and withdraw to the rear.

GENERAL.

Are control and cam rotating breech screw.—Remove the fixing screws and withdraw the control are or rotating cam respectively. (These fittings should not be taken off unless absolutely necessary.)

Vent axial, safety shutter and obturator.—Remove the keep pin from the “pin, retaining, axial vent nut and safety shutter” and withdraw the latter clear of the recesses in the vent axial nut and safety shutter. Unscrew the vent axial nut (or “lock with securing collar” in the case of Mark III vents) and remove the nut and safety shutter to the rear. Withdraw the axial vent and obturator from the front end of the breech screw.

Breech screw.—Insert a screwdriver in slot of “pin, actuating, retaining plate,” press in the pin and partially revolve it by means of the screwdriver until the indicating arrow on the pin corresponds with the middle of the word “dismantle” on the breech screw, then withdraw the breech screw from the front of the carrier.

Roller.—Remove the keep pin and roller axis pin and withdraw the roller.

Breech mechanism lever.—Remove the keep pin and nut from the crank shaft and withdraw the breech mechanism lever.

Breech mechanism lever bearing, crank shaft and crosshead.—Remove the keep pin and nut of the breech mechanism lever bearing securing screw and withdraw the securing screw. Withdraw the bearing and crank shaft from the carrier; at the same time remove the crosshead from the inner end of the crank shaft from inside the carrier.

Catch, breech mechanism lever.—Drive out the securing pin of the spring retaining block, slide the catch downwards in the breech mechanism lever and withdraw the catch, then remove the spring and retaining block.

Carrier.—Remove the keep pin from the carrier hinge pin and withdraw the latter, then remove the carrier and bearing washer.

The undermentioned fittings are not intended to be removed except on account of repair, as securing screws or stop rivets would have to be drilled or cut out to effect their removal:—

Pin, retaining, axial vent nut and safety shutter.

Plate, catch, breech mechanism lever.

Plate, retaining, breech screw.

TO ASSEMBLE THE BREECH FITTINGS.

The converse of the above takes place in re-assembling the fittings on the howitzer.

PART II.

CARRIAGE, TRAVELLING, B.L. 6-INCH 26-CWT. HOWITZER,
MARK I.*(Plates VII to XI.)*

The carriage is designed to admit of the howitzer being fired between 0° and 45° elevation.

The howitzer is mounted on a cradle along which it is free to recoil under the control of a hydraulic buffer and is returned to the firing position through the medium of a hydro-pneumatic recuperator. A cut-off gear is fitted to the saddle and buffer to shorten the recoil as the elevation increases in order to prevent the howitzer fouling the trail or ground, the recoil being approximately 52-inches with the howitzer horizontal and 24-inches at 45° of elevation.

In addition a quick-loading gear and depression stop are fitted, so that after firing, the howitzer can be brought rapidly into the loading position ($7\frac{1}{2}^{\circ}$ elevation) and *vice versa*, the gearing being so arranged that the sight line is not interfered with.

The cradle is pivoted by trunnions to a saddle and between the latter and the cradle is fitted the elevating gear.

The saddle is pivoted at its front end to the trail in such a manner that its rear end can be traversed 4° right and 4° left across the top of the trail, so that small changes in direction can be given without disturbing the spade which is fitted to the under-side of the trail at its lower end. The movement of the saddle is controlled by a screw and nut traversing gear, an indicator being fitted to show the angle of traverse.

The trail carries a cradle clamp with pawl which secures the cradle in the travelling position in order to prevent any strain coming on the elevating, traversing and quick-loading gears and is provided with a draught link at its front end for use when travelling in series.

The trail is supported on a 1st class "B" axletree and wheels and carries screw brakes which are for use in firing and travelling.

The sighting arrangements are on the reciprocating principle, consisting of a rocking-bar sight, a bracket to take the No. 5 carrier with No. 7 dial sight on the left side and a bracket with supporting pillar for the No. 1 dial sight on the right side.

The principal parts of the carriage are:—

- Trail with spade.
- Axletree and wheels.
- Brake gear.
- Saddle.
- Traversing gear and traversing indicator.
- Cradle with quick-loading gear.
- Cradle clamp.
- Hydraulic buffer with cut-off gear.
- Hydro-pneumatic recuperator.
- Elevating gear.

TRAIL.

The trail consists of two nickel steel side brackets joined at the front by a transom and at the rear by top and bottom plates. The top plate has two slats fixed across it to prevent the loading numbers slipping. The transom is pierced vertically to receive the pivot pin of the saddle. Each side bracket carries a M.B. clip on top about its centre, along which clips on the rear end of the saddle slide. The top front end of each side bracket is faced with a M.B. facing strip on which the saddle rests and is also fitted with holding-down clips (with lubricators) to engage with front guides on the saddle. Bearings are fitted on the under-side near the front for the attachment of the axletree and brackets are secured to each side piece for the attachment of the brake arms and on the top plate for the cradle clamp. The lower end is fitted with locking plates, spade, trail eye, lifting handles and sockets to take handspikes for lifting purposes. The trail eye is fitted with a preserving clip for the purpose of taking the wear off it. Clips to hold the portable air compressor in position whilst charging the recuperator are riveted to the top plate near the lower end and spring clips are provided on the left side, about the centre, to hold a steel cylindrical case with cap, in which is carried the "Memo. of examination." Fittings are provided on the trail for housing a rammer, piassaba brush, two handspikes, loading tray, end stave, and No. 9 lubricating can. A leather pocket is riveted to the trail on the right side in which is carried two "rimers, vent axial." A draught link is attached to brackets at its front end and serves to connect another carriage when travelling in series, the front end of the link being forked and provided with a pin for this purpose.

When not in use the draught link is housed to the muzzle of the howitzer by means of a wire rope sling. It is passed through the draught link, over the chase in front of the guide ring and is fastened by means of the spring hook and thimble, as shown at Fig. "A."

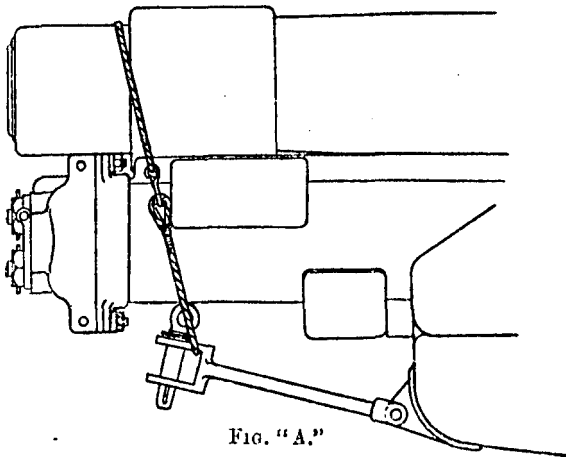

FIG. "A."

AXLETREE AND WHEELS.

Axletree.—The axletree is a 1st class “B,” No. 306. The body is a steel forging which fits bearings in the trail and is provided with cranked extensions through which it is bolted to the latter. The extensions are fitted with 1st class “B” arms. Brackets attached to the shoulders are recessed and provided with L-leathers held in by steel plates. The L-leathers surround the inner ends of the pipe boxes and prevent the ingress of dirt, &c. The outer end of each arm is fitted for a linch pin and an adjusting collar. The collar has a number of recesses, through which the linch pin passes, cut in one face; the recesses vary in depths from $\cdot 2$ -inch to $\cdot 5$ -inch, increasing by $0\cdot 05$ -inch, so that any reduction in the length of the pipe box, due to wear, may be compensated for.

Wheels.—The wheels are 1st class “B,” No. 12, of double spoke construction, 5-feet in diameter, with a 6-inch steel ring tire.

The nave consists of two M.B. flanges and a M.B. pipe box, which is in one casting with the back flange. The inner end of the pipe box is shaped to fit into the dust excluder on the axletree, while its outer end is screw-threaded to receive a M.B. bearing for the drag washer and a dust cap. The bearing screws up against a shoulder on the pipe box; it forms a stop for the dust cap, the latter being secured to it by two pins. The pipe box is shaped internally to fit over the axle arm and is provided with two grease boxes.

The drag washer is free to revolve around the bearing and is held in position by the dust cap.

The front flange is bolted to the back flange by 14 nave bolts which pass in between the feet of the spokes and are nutted up front and back alternately.

The spokes are of oak, 14 in number, the back spokes are dished, the front ones being straight. Their upper ends fit into spoke shoes which are riveted to the felloes. The felloes are of ash, seven in number, connected together by the tongue of every alternate spoke passing into the joint, thus forming dowels. The tire is held on the felloes by 14 bolts, two to each felloe; they are countersunk on the outside and nutted up on the bosom of the wheel.

The wheels are held on the axle arms by the adjustable collars and linch pins mentioned above.

In some cases extension felloes are fitted to the outer face of the wheel. They are of ash, 7 in number and are secured by clip bolts which fit around the spokes close to the bosom of the felloe. The bolts pass through the extension felloes and are nutted up on the outside. The sole of each extension felloe is fitted with a steel strake, secured to the felloe by screws.

Where the extension felloes are not fitted, girdles are provided, the method of assembling which is shown on Plates XIII and XIV.

The girdle comprises ten channels and ten wood shoes and, in use, is to obviate the possibility of the wheels sinking into soft ground and to facilitate travelling. The channels are provided with holes at each end and are coupled together by means of pins and spring washers. When attached to the wheel the channels are in the form of an endless band. A wood shoe is fitted between each

channel on the connecting pins by means of wing nut attachments on each shoe.

The girdles are attached or detached by means of a pinch bar for the channels and a key for the wing nuts.

BRAKE GEAR.

(*Plate XII.*)

The brake gear is of the swinging arm type, each side acting independently.

The gear on either side consists of a brake arm which is pivoted to the side bracket of the trail. The outer end of the arm carries a shoe in which is secured a C.I. brake block to bear against the tire of the wheel. To the centre of the brake arm is pinned a spring carrier, over the front end of which are placed six discsprings which are held between a shoulder and a nut on the carrier and give the necessary resilience in the gear to prevent the wheels becoming dead locked; to the carrier is secured the rear end of the brake screw (which serves as an actuating rod), the front end of which is screw-threaded to work in a nut to which is attached a handwheel. The travel of the screw through the nut is limited by a stop collar keyed to the screw. The nut is carried in a swivel bearing pivoted to a bracket attached to the axletree and is prevented from having any end movement by a shoulder in front and screw cap in rear, consequently when the handwheel is turned the brake screw is drawn through the nut, thus pulling on the brake arm and bringing the block against the tire of the wheel. The reverse action takes place in taking off the brakes.

When girdles are employed on the wheels the brake screws and carriers are disconnected from the brake arms and the arms and screws folded into the trail, where they are secured to brackets by housing pins.

SADDLE.

The saddle consists of two nickel steel side pieces connected at their front ends by a curved transom. The transom has a bushed opening in its centre, screw-threaded to receive a traversing pivot by means of which the saddle is pivoted to the trail. Trunnion bearings are formed at the top of the side brackets for the reception of the cradle trunnions, which are held in position by capsquares. At the front and rear of each side piece are guides and clips respectively which engage with clips on the trail to prevent the saddle lifting on firing.

A locking bracket for the spring plunger of the quick-loading gear to engage in and so hold the cradle in the loading position, is riveted to the inside of the right side piece and a bracket to carry the elevating gear and sight bracket is riveted to the outside of the left side piece at the rear. There is also a bracket riveted to the right side piece in which is secured a pillar for the No. 1 dial sight.

Leather cases to carry the No. 7 dial sight in its carrier and sight clinometer, are fitted to the left side of the saddle and a case to carry the No. 1 dial sight is fitted to the right side.

TRAVERSING GEAR.

(Plate XXIII.)

The traversing gear is interposed between the rear end of the saddle and the trail on the left side. It consists of a M.B. bearing which is pivoted in a bracket on the trail in which a steel traversing screw is held by means of a collar formed on it and a hand-wheel for operating the gear which is secured on its outer end by a nut.

The threaded portion of the screw works in a M.B. link nut, one end of which is attached to an arm on the elevating gear case by a connecting pin, while the other, or free end, enters the steel cover which is provided for the traversing screw. One end of the cover is screwed into the pivot bearing and is provided with a nut by means of which the cover may be adjusted for length or play, while at the other end is a leather packing ring and cap to prevent the ingress of grit or dirt.

The maximum angle of traverse is 4° right and 4° left, the amount of traverse being indicated by a pointer on the saddle reading graduations on a scale plate fixed to the bracket on the trail, the bracket being formed with two traversing stops.

One revolution of the handwheel equals $\frac{1}{4}^\circ$ of traverse.

Note.—The traversing gear must be placed at zero before connecting the cradle clamp to the cradle.

CRADLE.

(Plate XV.)

The cradle is -shaped and is provided about its centre with trunnions to fit into the trunnion bearings of the saddle in which they are held by hinged cap squares. Roller bearings surround the cradle trunnions to reduce the friction in elevating and depressing the howitzer. Caps, with flanges to fit outside the saddle bearings, are screwed into the trunnions and are retained by set screws. A top plate is fitted to the cradle, in which are formed top guideways to take the guides of the howitzer and under guideways in which slide the guides on the body of the hydraulic buffer and recuperator. The front end is closed by a cap to which are attached the piston rod of the hydraulic buffer and ram of recuperator. The cap is fitted with a door which enables the recuperator to be charged with air or the air pressure to be tested without removing the cap. On the left side are fitted brackets for the quick-loading gear and on the right side for the cut-off and quick-loading gears: brackets are also provided on the underside at the front for a depression stop. The rear part of the cradle projects beyond the breech of the howitzer to support the latter in the recoiled position and is prepared to form a rest for the loading tray in loading. This projection is prepared on the underside to receive the cradle clamp securing pins.

A leather pad with brass facing plate, contained in a M.B. bracket is fitted to the front end of the cradle to act as a beating face to the howitzer in running-up.

A scale of degrees is marked on the left side of the cradle to indicate the correct amount of recoil according to the elevation at which the howitzer is fired and is read by a spring pointer, fixed to the front guide ring of the howitzer.

QUICK-LOADING GEAR.

(Plate XXIII.)

This gear is provided for bringing the howitzer rapidly from the loading to the firing position and *vice versa*. It consists of a longitudinal actuating lever which is pivoted near its front end to a bracket on the right side of the cradle. A cranked arm is formed at the front end of the lever; the arm is forked and to it is pinned a spring plunger, which is supported in a bracket on the right of the cradle and which engages in a recess in a locking bracket on the saddle when the howitzer is in the loading position. Just in rear of this arm the lever is shaped to work against a small friction roller carried on a second longitudinal lever on the right end of a cross spindle carried in bearings on the underside of the cradle, on the left end of which is a bent lever which has a spring plunger pinned to its upper end, supported in a bracket on the left of the cradle, which engages a recess in the elevating arc when in the firing position.

Action.—After firing, the hand lever is raised; this, acting through the second lever, cross spindle and bent lever, withdraws the firing or left plunger from its recess in the elevating arc, compressing the spring and brings the cradle and howitzer to the loading angle, viz., $7\frac{1}{2}^{\circ}$ elevation, at which position the loading or right plunger engages with the recess in the locking bracket on the saddle. A stop (see page 43) is provided to bring the howitzer to rest at the proper loading angle. It consists of a wood block bolted to brackets on the under-side of the cradle, which, when the howitzer is depressed after firing, fouls the transom of the saddle. If it is required to depress below the loading angle the block must be removed. Before working the quick-loading gear the stop must be in position, or damage will be done to the gear. Loading being completed, the hand lever is pressed down, withdrawing the loading or right plunger from its recess and elevating the cradle, till the firing or left plunger, which rides along the arc, comes opposite its recess, into which it engages under the action of its spring, thereby locking arc and cradle together, and the latter can then only be moved by means of the elevating gear.

Note.—The quick-loading gear must be disengaged for traveling by withdrawing the locking plunger from the elevating arc, the hand lever being supported by the pawl of the cradle clamp.

CRADLE CLAMP.

(Plates IX and X.)

The cradle clamp consists of a steel bar shaped at each end to engage with a pin on each trail bracket. The bar is formed with two double lugs on its upper surface through which it is pinned to

projections on the underside of the cradle when travelling and to the housing brackets on the trail when not in use.

To obviate the possibility of the plunger hole of the quick-loading gear becoming distorted by shock while travelling, the clamp is provided with a pawl for the purpose of supporting the hand lever of the quick-loading gear and thus hold the plunger in the disengaged position.

The pawl is of steel, formed with a flange at one end by which it is riveted to the cradle clamp and shaped at the other end to engage with the hand lever of the quick-loading gear. Thus, with the clamp in position, the hand lever of the quick-loading gear fouls the pawl, raising the lever and so withdrawing the plunger from the elevating arc.

The cradle clamp is made removable so that it can be removed to clear the loading numbers when working at the breech of the howitzer.

Note.—The traversing gear must be at zero when connecting the cradle clamp to cradle.

HYDRAULIC BUFFER, &c.

(Plate XV.)

The buffer and recuperator cylinders are contained in a steel cylinder block forming a body, which fits inside the cradle and is provided with a guide on either side to slide in guideways in the top plate of the latter. The body is attached at its rear end to the breech ring of the howitzer by two connecting studs with nuts and thus recoils with it, while the piston rod of the buffer and ram of recuperator being attached to the front cap of the cradle remain stationary. In future manufacture the nuts securing the breech ring of the howitzer to the recuperator body will be kept in position by a locking plate instead of by castellated nuts secured by a split pin. Four parallel openings are bored through the body, viz., top one for buffer cylinder, bottom, for liquid cylinder of recuperator and a H.P. cylinder on either side.

Hydraulic Buffer.—The buffer cylinder has two spiral grooves cut in its interior surface to rotate the rotating valve during recoil and run up. The front end is closed by a steel stuffing-box which is screwed into it against a steel joint ring and a fibre washer to make a tight joint. The stuffing-box contains an L-shaped leather or rubber packing ring,† which is held in position by a hollow gland, with M.B. butt ring, in which is placed a compressed packing ring. In front of this is placed a sleeve against the flange of which bears a spiral spring, the whole being kept in position by a cap which screws on to the stuffing-box and bears against the spring. The stuffing-box and cap are kept from unscrewing by locking plates.

The rear end is closed by a steel control cylinder forming a buffer extension which is screwed in against a fibre washer to make a tight joint and is kept from unscrewing by a locking plate. It is provided with a projecting portion at the front which acts as a guide when inserting the control cylinder into the hydraulic buffer.

† When L-rubbers are fitted, a plate notifying the same is attached to the front end of the recuperator body.

Holes and slots are provided in the projecting portion to allow oil to pass on run-up, or air to escape when filling. Internally it is bored out to form a control cylinder, and provided with a M.B. bush at the entrance; a small passage bored through it places the control cylinder in communication with the buffer cylinder. This passage is closed by the stem of a plug adjusting run-out on which are formed flats, by means of which the rate of run-up of the howitzer is regulated. The piston rod and piston are of steel in one forging with the control plunger. The piston is lined with a R.B. ring (in halves) around its outer circumference, to prevent it scoring the cylinder. The rod passes out through the stuffing-box at the front end and is nutted up to the front cap of the cradle. Inside the cap, the rod has feathered to it a steel sleeve on which is formed a toothed bevel segment which forms a part of the cut-off gear. The piston has two plain ports for the passage of liquid from one side to the other on recoil and run-up.

The control plunger projects from the rear of the piston and has a flat cut on it for a greater part of its length. The remaining portion is cylindrical and is a good fit inside the control plunger cylinder. The base of the plunger is prepared for the reception of the rotating valve and its fittings.

The rotating valve is of R.B. and fits in rear of the piston over the control plunger, around which it is free to revolve. It has two shaped ports for the passage of liquid and has two studs or feathers on its periphery to work in the spiral grooves of the buffer. The valve is held up against the rear face of the piston by a steel thrust ring which is feathered to the control plunger and in turn is held by a nut and keep pin, the nut being provided with slots to admit of adjustment between thrust ring and rotating valve.

The front end of the buffer cylinder is provided with a filling or air hole closed by a screwed plug and vulcanized fibre washer.

A sniffing valve is fitted in a hole (formerly the left air-hole) in the front end of the buffer cylinder; it is actuated by a spindle, which passes out through the cradle cap, and is fitted with a knob. This arrangement permits of air, which may have accumulated in the buffer cylinder, being released without removing the cradle cap.

GRAVITY TANK.

(Plate XVIII.)

A G.M. tank to hold 5-pints of liquid is secured by four fixing screws to the guide ring of the howitzer on the right side. Its duty is to replace any loss of liquid from the buffer cylinder. The tank is provided at the top with a filling-hole fitted with a brass gauze strainer and closed by a screwed plug with dermatine† washer; a small relief valve is nutted to the bottom of the plug and fits inside the strainer. To prevent a vacuum forming in the tank, six holes are bored vertically through the filling-hole plug and are closed on the under-side by a dermatine† washer which is held in position by the nut securing the relief valve and thus forms an air valve; the nut is rounded to allow of movement of the washer. The top

† Washers will be of Navy red material in future supply.

of the tank is closed by a gunmetal cover with dermatine† washer, which permits of the tank being cleaned out when required. To indicate the liquid level a sight glass, with reflector, is fitted to the bottom of the tank in rear and a copper feed pipe, in two parts, with suitable connections, places the tank in communication with the rear end of the buffer cylinder. The Mark II tank differs principally from the Mark I described above in having the filling-hole formed in the tank cover instead of in the body of the tank and in the strainer being conical in shape instead of cylindrical.

Tanks of future manufacture, will, to enable the tank and pipe to be cut off should they become damaged, be provided with an isolating valve (*Plate XXIII*); which consists principally of a M.B. body, a steel spindle and spindle head. Leakage past the valve is prevented by a ring of asbestos packing with M.B. neck rings and a M.B. gland.

A key is provided for adjusting the valve, if required, and is prepared at one end with a squared portion, which engages a recess in the spindle.

CUT-OFF GEAR.

(*Plates XIX and XX.*)

This gear consists of a link bolted to the trunnion bearing on the right side of the saddle. Held in a guide on the right side of the cradle is a steel actuating rod, the rear end of which is forked and pinned to the link, while its front end is attached to a short, vertical lever which is formed on the outer end of a short spindle. The latter passes inside the cradle cap and carries on its inner end a bevel segment which engages with the bevel segment feathered to the piston rod. Thus, on elevating the howitzer, the rod pulls upon the short lever rotating the cross spindle, bevel segments, piston rod and piston, thereby decreasing the flow space between the ports in the latter and those in the rotating valve, which is held fast by its feathers and grooves in the cylinder. This increases the resistance set up in the buffer cylinder during recoil, thereby shortening the recoil of the howitzer. The recoil varies from 52-inches, howitzer horizontal, to 24-inches at 45° elevation.

Equipments provided with Martini-Metford or "R.II." lock firing mechanisms will, in order to obviate damage to the mechanism, be fitted with a Mark II actuating rod, trunnion link and connecting pin, to enable the recoil to be shortened by about 5-inches.

The rod is of increased length and has the end for attachment to the link made solid; the link has the hole for connecting pin at 3.4-inches, instead of 6.3-inches, from the centre, while the connecting pin is provided with a nut instead of keep pin.

RECUPERATOR.

(*Plate XV.*)

The recuperator is on the hydro-pneumatic principle and consists of a liquid cylinder in which works a ram and two H.P. cylinders which contain liquid and compressed air. The H.P. cylinders are

† Washers will be of Navy red material (compressed asbestos fibre) in future supply.

connected at their rear ends by an equalising passage, while they are also connected to the front of the liquid cylinder by an opening in the cylinder through which liquid is forced on recoil and run-up.

The liquid cylinder consists principally of a steel tube which is screwed into the lower opening in the cylinder block; thus, between the exterior of the tube and the wall of the opening in the block, an annular space is formed surrounding the tube throughout its entire length and filled with liquid when the system is charged. This space is in communication with the rear of the H.P. cylinders by openings in the cylinder block and with the liquid cylinders by means of holes formed in the tube in front of the throttle valve seating.

The liquid cylinder has its rear end closed by a perforated dust cap. Fitted to the centre of the cap is a stud which carries a rubber washer held in position by a brass disc and nut. The perforations allow any liquid which may leak past the piston head to get clear, otherwise the howitzer would not return fully to the firing position after recoil. The holes in the cap also prevent a vacuum forming in the cylinder in rear of the ram.

The front end is closed by a stuffing-box, packing and cap, in the same manner as the buffer cylinder, except that the steel joint ring in rear of the stuffing-box is omitted. Near its front end, the cylinder is reduced in diameter to form a seating for a throttle valve which fits loosely around the ram and is kept up to its work by a spiral spring, one end of which bears against the valve and the other end against the centring collar.

A manganese bronze centring collar is fitted on the ram between the stuffing box and throttle valve in order to keep the valve spring in position.

The valve is provided with a coned head to fit tightly on its seating. Holes are bored through the head to allow liquid to pass back again into the cylinder after recoil.

The Mark III recuperator ram is of steel; its front end is secured by a screwed collar inside and a nut outside, to the front cap of the cradle. Screwed into the collar and ram is a stud which engages between two stop pegs screwed into the front cap of the cradle on the inside to prevent the ram moving with connecting nut when being tightened up or released. Its rear end is provided with a packed piston. The packing is divided into two parts, front and rear. The front part consists of two U-rubbers with supporting rings and stop ring, held in position by a nut screwed and pinned to the ram. To prevent an intensified pressure being placed on the rear "U" rubber a steel stop ring, in halves, is fitted into an annular recess formed in rear of the rear supporting ring. The rear part consists of a compressed packing ring and supporting ring, held in position by a spiral spring compressed by a nut screwed on to the rear end of the piston head. The nut is kept from unscrewing by a spring plunger contained within the piston head and fitting a squared opening in the nut.

The Mark I* and II* rams are Mark I and II rams respectively, which have been modified to take a detachable head generally, similar to the head of the Mark III.

The ram is hollow and at its front end is prepared to take an

"adapter, oil filling," to which the pipe from the "pump, liquid portable," is connected when filling. Two small holes at the rear connect the interior of the ram with the liquid cylinder. When the adapter is not in use the opening at the front is closed by a screwed plug.

The H.P. cylinders are plain tubes, their front ends being closed by steel plugs. An equalising passage, formed in the cylinder block connects them at their rear ends, which are also connected to the front of the liquid cylinder from a point in front of the throttle valve, by the annular space which surrounds the liquid cylinder.

The front closing plugs are fitted with air-holes at such a level as to ensure the correct charging of the recuperator with liquid when the howitzer is level both longitudinally and transversely and in addition, the left plug is fitted with an air valve and prepared to take an "adapter pressure gauge" to which is connected the copper pipe leading from the portable air compressor when charging or a pressure gauge when testing the air pressure in the system. When the adapter is not in use, the opening is closed by a screwed plug.

ACTION OF BUFFER AND RECUPERATOR.

Before firing, the operation of elevating prepares the buffer for the correct length of recoil.

On firing, the howitzer recoils along the top of the cradle, taking with it the buffer and recuperator cylinders, the piston rod of the former and ram of the latter remaining stationary. As the buffer is drawn back, the liquid passes through the ports in the rotating valve and piston from front to rear. At the commencement of recoil the ports in the piston are uncovered more or less by the rotating valve (the amount of opening varies with the elevation), but as the recoil proceeds the rotating valve is caused to revolve on the piston rod by the grooves in the cylinder, thus causing the ports to be gradually closed, which graduates the pressure and absorbs the energy of recoil of the howitzer.

At the same time the ram of the recuperator forces the liquid from the liquid cylinder into the H.P. cylinders, the throttle valve being forced off its seating for this purpose; the liquid entering into the H.P. cylinders raises the air pressure in the system.

On the recoil ceasing, the throttle valve closes, the air expands and forces the liquid back through the holes in the throttle valve into the liquid cylinder, thus returning the howitzer into the firing position. The latter is prevented from running up with violence by the resistance set up in the hydraulic buffer by the passage of the liquid from rear to front of piston, by the slowness with which the liquid is forced through the restricted holes in the throttle valve and also by the control plunger, which latter, as the howitzer nears the firing position, enters its chamber and displaces the liquid therein, first over the tapering flat on the plunger and also past the adjustable valve through the side channel, but finally through the latter means only.

ELEVATING GEAR.

(Plate XXIII.)

The elevating gear is supported in a bracket attached to the saddle on the left side at the rear. Supported in bearings in this bracket is an oblique shaft which has a hand-wheel at its rear end and a worm near its front end. The worm gears into a worm-wheel formed on the outer end of a short cross spindle, on the inner end of which is a spur pinion which engages into the elevating arc. The worm shaft is fitted with friction washers at either end of the worm and an adjusting bush with locking plate at its front end. The wheels and pinions are closed in by a metal cover secured to the bracket by screws. The elevating arc fits loosely around the cradle trunnion and has a recess to take the firing or left plunger of the quick-loading gear. When this plunger is engaging in its recess, the cradle and arc are locked together and elevation or depression can only be given by working the gear. The arc carries on its upper side at the front end a connecting link for the attachment of one end of the connecting rod of the sight operating gear.

The arc is fitted with a steel emergency clamp for use in the event of the plunger or plunger bracket being broken, so as to enable the cradle to be locked to the arc. The clamp is of steel, formed in three parts and secured to the elevating arc by two studs with nuts and two screws. A scale plate, graduated up to 45° , is attached to the bracket supporting the sight, the graduations being indicated by a pointer attached to a bracket on the saddle. One revolution of the handwheel equals 1° of elevation.

Note.—To avoid damage to equipments not having a pawl fitted to the cradle clamp, when travelling over rough roads the elevating gear should invariably be thrown out of engagement with the cradle when connecting the latter to the "cradle clamp." This is done by raising the actuating lever of the "quick-loading gear" and rotating elevating handwheel two or three turns, thus throwing the plunger out of gear with the elevating arc.

DIMENSIONS, &c.

CARRIAGE AND LIMBER.

		ft.	in.
Height	{ to axis of howitzer—trail spade buried to open sight line to No. 7 dial sight line to No. 7 dial sight eyepiece	4	3
		4	10
		5	4.8
		4	9 $\frac{1}{4}$
	maximum	{ carriage, over sight, firing position... .. carriage, travelling position, sight removed limber, over top of guard irons	5
		5	5 $\frac{1}{2}$
		5	2
Width, maximum, of carriage over axles	...	7	10

DIMENSIONS, &c.—*continued.*Carriage and Limber—*continued.*

						ft.	in.	
Length of	{	carriage with howitzer	17	6	
		limber {	with pole. Centre of axle to point of pole	12	9½	
						5	9	
Length (Total)	{	without pole (end of pole on ground)	31	7	
		without pole (to front of engine draught connector)	24	6	
		between axletrees	13	9	
Greatest projection beyond track of wheels on each side.	{	carriage	0	7½	
		limber {	with outrigger gear	1	9	
						0	6½	
						6	7	
Wheels	{	track {	carriage	6	1	
			limber	5	0	
		height {	carriage	4	8	
			limber	48	0	
Space required to turn in	{	with outrigger and pole	45	4	
		without outrigger and pole			
						deg.	min.	
Angle of lock	45	0	
Elevation, maximum	45	0	
Depression (firing)	0	0	
Slope of trail. Trail spade buried							2.027	in 10

WEIGHTS.

						cwts.	qrs.	lbs.
Carriage (with 1st class wheels and no girdles)	47	0	22
Carriage, with howitzer	72	2	22
Limber	10	0	0
Behind team	82	2	22
Pressure of trail on ground	2	0	0
Pressure on limber hook	1	2	0

PART III.

SIGHTING.

(Plates XXIII to XXVII.)

The carriage is provided with the following sighting arrangements:—

Sight, rocking-bar.	} Left Side.
Sight, dial, No. 7.	
Carrier, No. 7 dial sight, No. 5.	
Clinometer, sight.	
Sight, dial, No. 1.	Right Side.

SIGHT OPERATING GEAR.

(Plate XXIII.)

The sights on the left side are moved through the same angle as the howitzer by means of a parallel motion operated from the elevating arc. For convenience in laying, the sights are placed as far back as possible and, as they cannot be attached to the cradle, the parallel motion is necessary to transmit the motion from the elevating gear to the sights. When the quick-loading gear is worked no movement of the sights takes place as the cradle is then unlocked from the elevating arc, but on working the elevating gear the arc is moved, which, transmitting its movement through the sight operating gear, causes the sight to be rotated on its pivot. The upper end of the link on the elevating arc is formed into a crosshead which is slotted to take a sliding block held in position by two adjusting screws. The screws pass through the front and rear end of the crosshead, respectively and their points bear against the block. By means of this block and screws the sight is adjusted for elevation. To the sliding block is attached the front forked end of a parallel rod, the rear end of which is attached to the top of the sight bracket by a front and rear securing nut. By manipulating these nuts the correct length of rod for the proper movement of the sight is obtained, when the sight is first set up, or on repair.

SIGHT, ROCKING-BAR.

(Plate XXIV.)

The sight bracket is pivoted at its lower end to a bracket on the saddle and is fitted with bearings to which is pivoted an oscillating bracket which can be rocked in a plane at right angles to the axis of the piece by the cross-levelling gear. The latter consists of two nuts and a screw with milled head and is interposed between the oscillating and sight brackets; a cross-level carried on the back of the former indicates when the sight is level transversely. In future manufacture of sights the cross-level carrier will be secured to a

supporting bracket attached to the body of the range bracket instead of being carried on the oscillating bracket. By working this gear till the bubble of the cross-level is central any difference in level of wheels is allowed for. The oscillating bracket is in the form of a casing and carries the sight gear, which is protected by a cover secured to the casing by screws.

The sight gear consists of a quadrant or range bracket pivoted at its lower end inside the oscillating bracket; the quadrant is fitted with an inside toothed rack. Gearing into the rack is a pinion carried on a cross spindle on the outer end of which is secured the range drum. Between the drum and pinion the spindle carries a worm-wheel into which gears a worm on the upper end of an oblique spindle, at the lower end of which is a handwheel for actuating the gear. To allow of any backlash between the rack and pinion being taken up, the pinion is made in two parts. These are so arranged that one may be slightly rotated in relation to the other and locked.

Thrust balls are interposed between the worm and its bearings to reduce the friction caused by end thrust.

The range drum is fitted with a range dial ring graduated to 45° , the graduations being indicated by a pointer on the oscillating bracket. The dial ring is held in position by a clamping ring with screws.

In future manufacture the range dial will be graduated in whole degrees only and the reader will be provided with a minute vernier scale, reading from 0 to 60-minutes in multiples of 5-minutes for the purpose of applying odd minutes of elevation.

Consequent on this modification the "Ring, range dial," "Ring, clamping, range dial" and "Reader, range dial" will each be known as *Mark II*.

Brackets on the quadrant support the sight clinometer, sight bar and No. 5 carrier with No. 7 dial sight. The side of the dial sight clamp is cut away and a loose dog clamp fitted in its place, so as to ensure a firm grip on the dial sight.

The sight bar is a tubular steel bar pivoted horizontally near its front end through an eccentric bush in the bracket on the quadrant in which it is secured by a washer, nut and pin. The front end of the bar carries an adjustable acorn foresight, protected when not in use by a cap with chain, while its rear end is slotted to fit over a projection on the deflection nut.

A bracket is provided on the top right side in which is cut a V notch for use in conjunction with the acorn foresight. The deflection gear is carried in a crosshead formed at the rear of the quadrant and consists of a screw with milled head, nut in two parts with spring, scale plate and graduated drums. The scale plate is attached by screws to the back of the crosshead and is graduated to 5° R and 5° L, the graduations being indicated by an arrow on the nut. The scale plate is scribed with a red mark to indicate "True zero" for use when testing the sights. The drums fit over the ends of the screw, one either end and are graduated in intervals of 5-minutes, with indicating arrows on the crosshead. The graduations on the scale plate and micrometer drums are filled in with black wax on a bright metal background, and against each numbered

graduation, the letter "R" or "L" is marked to signify "Right" or "Left" deflection respectively.

Drift is allowed for by inclining the sight at an angle of $4^{\circ} 30'$ to the left and giving it a permanent deflection of $25'$ right.

CLINOMETER, SIGHT.

(Plate XXIV.)

The sight clinometer is used to allow for the "angle of sight" and admits of 20° elevation or 20° depression. It is constructed so that it may readily be attached to the rocking-bar sight. It consists principally of a cradle with a worm spindle and a toothed arc with a spirit level. The cradle is fitted on the under-side with spring clips for fixing it to the quadrant and with radial grooves on the top, in which the arc slides; the worm spindle passes through the centre of the cradle and is supported at each end by movable bearings, one of which is pivoted to the cradle and the other free to slide in grooves for a limited distance, so that the worm on the spindle may be readily disengaged from the teeth in the arc when necessary for quick adjustment. The worm is kept up to its work by a flat spring with a bearing surface on its under-side and each end of the spindle is fitted with a micrometer collar marked to read minutes in multiples of 5 which is fitted with a "P" bubble. The "P" bubble spirit glass is painted with a radium compound on its underside, which makes it self-luminous for use at night, and the letter "R" is painted in red on the cradle in order that clinometers fitted with such bubbles may be readily distinguished. The arc consists of a toothed segment with a spirit-level above; it slides in the grooves on the cradle and the teeth engage with the worm on the spindle; an adjustable pointer is fitted below the level for reading the degrees of elevation and depression engraved on the cradle.

When not in use the clinometer sight is carried in a leather case on the left side of the saddle.

CARRIER, NO. 7 DIAL SIGHT, NO. 5.

The No. 5 carrier consists of a steel bar, which can be clamped into a bracket on the quadrant. The upper portion is shaped to take the dial sight. It is also fitted with an arrangement for giving deflection up to 10° right or left. This consists of an upper and lower bracket.† The upper bracket is connected to the dial sight by means of four screws and a feather; fitted through it is a worm with a minute micrometer head at each end, readers for which are fitted on the bracket, a leather dust excluder being attached to the bracket by five screws to prevent the ingress of dirt or grit. Along one face is fixed the deflection degree scale. The lower bracket, which is fixed to the carrier, has worm teeth cut on it, into which the worm gears. There is also a reader for the deflection degree scale attached to it. Against each numbered graduation, the letter "R" or "L" is marked, to signify "Right" or "Left" deflection respectively.

† In future manufacture of carriers the deflection brackets will be omitted.

SIGHT, DIAL, No. 7.

(Plates XXV and XXVI.)

The No. 7 dial sight is employed for indirect laying. The upper part of the sight can be revolved through a complete circle independently of the eyepiece, thereby allowing the layer to see objects in any direction without moving the position of his eye. Owing to the height of the sight, the layer can lay on objects directly behind him, the line of sight being above his head.

Mark III.—The optical arrangements are so designed that an object viewed through the sight is always seen erect. They consist of:—

F, the *upper prism*, which is mounted in the upper portion of the sight. Its face can be turned in any direction with reference to the eyepiece K, the angle between the two being indicated on the dial plate A by means of a reader on the bracket N.

G, The *centre prism*, which by means of bevel gearing is made to revolve at half the speed of the upper prism F; this arrangement ensures the object layed on always appearing erect.

H, a double reflecting roof prism.

J, the object-glass.

K, the eyepiece, with two eye lenses.

M, a glass diaphragm, upon which are engraved vertical and horizontal lines, with gaps near their centres. A radium dot is placed just below the optical centre on the vertical graticule and is for use at night.

A glass window in the eyepiece allows the lines to be illuminated at night.

The magnification of the system is 4-diameters and the field of view is 10° . There are no arrangements for focussing the sight.

The principal mechanical parts are the following:—

B, the *supporting pillar*, in which are suitably mounted the eyepiece K, fitted with a dermatine eyeguard, the lower prism H and the object-glass J. The "plug, supporting pillar," V is screwed into its lower end and on it is a castellated nut, which is prevented from unscrewing by a split pin. Near the upper end of the supporting pillar is a coned seating W, which fits accurately on to a coned bearing on the carrier.

The projection X, which fits into a slot in the carrier, prevents the sight revolving.

C, the *worm-wheel bracket*, is firmly secured to the supporting pillar B. In it is mounted the slow motion traversing gear, which consists principally of a worm spindle S, the worm on which engages with the worm-wheel D. On either end of the spindle is mounted a milled head and an adjustable micrometer scale drum. The drums are graduated in opposite directions in divisions of 10 minutes, right angles being denoted by white lines on a black background and left angles by black lines on a brass background. For future manufacture the distinctive marking will be omitted, the graduations being filled in with black wax on a bright metal background; *right* angles being indicated by the letter "R," and *left* angles by the letter "L." The drums can be adjusted by loosening the caps inside the milled

heads with a special wrench and turning them independently of the milled heads. The readers for the drums are on the worm-wheel bracket. Each turn of the worm spindle moves the upper part of the sight through 5° . The worm spindle is mounted in an eccentric, which when turned by raising a lever near the left drum, throws the worm out of gear with the worm-wheel. This enables the upper part of the sight to be revolved rapidly. Two projections are formed on the worm-wheel bracket, the front one, which is provided to engage a recess formed in certain carriers in order to prevent the sight from turning, is not used with the No. 5 carrier; the rear one fits into a groove in the upper bracket of the carrier and in conjunction with four screws which engage holes in the upper bracket, ensures the sight revolving when deflection is being put on.

D, *the worm-wheel*, has teeth, which engage with the worm spindle S, cut on its lower portion. It extends upwards and is firmly secured to the upper prism holder E and the dial plate A by screws, &c.

Y, *the centre prism holder*, fits accurately in the supporting pillar B. To it is attached the prism mount P, in which the centre prism G is firmly held.

The prism holder is free to revolve and is forced to do so at half the speed of the upper prism holder E, by means of three bevel wheels. The axis of the vertical bevel wheel Z is formed on a projection from the prism holder. This wheel engages with the lower bevel wheel Z¹, which is fixed to the supporting pillar and also with the upper bevel wheel Z², which is fixed to the upper part of the sight. When the upper part of the sight is revolved the axis of the centre bevel wheel and consequently the central prism, are forced to revolve at half the speed of the upper part of the sight.

E, *the upper prism holder*, as previously mentioned, is rigidly attached to the dial plate and worm-wheel. In it are suitably mounted the upper prism and a glass window.

A diaphragm is hinged to the case of the upper prism holder, by means of which the focus and parallax at short distances can be corrected without any appreciable loss of light.

The diaphragm, which is fitted with a shutter, is only for use at short distances of approximately 20 yards or under.

A spring is provided which retains the diaphragm and shutter in position when closed.

In the centre of the diaphragm is a hole $\cdot 25$ -inch in diameter, and in the shutter one of $\cdot 125$ -inch diameter.

If the object to be viewed is only a few feet away, the shutter is to be used and the object viewed through the small hole.

When the dial sight is used at a distance of more than 20 yards the diaphragm is to be lowered from the front of the window.

To enable the line of sight through the upper prism to be elevated or depressed, a small toothed arc is attached to the mount of the prism. The teeth of this arc engage with a worm spindle R. At the top of this spindle are mounted a milled head and adjustable drum, engraved with a zero mark. The reader is engraved on the prism holder; 17° elevation or depression can be given. The letters "E" and "D" are engraved against each numbered graduation to denote "Elevation" and "Depression" respectively.

A crosshead with open sights (or view finder) is mounted on the right side of the upper prism holder. Its movement is regulated by that of the upper prism, but as the latter has a reflecting surface the former has to move twice as quickly. This is arranged for by a toothed wheel on the prism mount gearing with a toothed wheel, having only half the number of teeth, on the pivot of the crosshead with open sights.

Engraved on the under portion of the crosshead is a zero mark, indicated by an arrow on the upper prism holder.

A, *the dial plate*, as previously mentioned, is firmly fixed to the worm-wheel and upper prism holder. It is cast with two lug pieces on it to prevent any play between the dial plate and the case upper prism holder. Two scales, each reading from 0 to 180 in single degrees, are engraved round the dial plate; right angles being denoted by white lines on a black background and left angles by black lines on a brass background. For future manufacture the distinctive marking will be omitted, the graduations being filled in with black wax on a bright metal background, *right* graduations being indicated by the letter "R" and *left* by the letter "L." The graduations are read by a reader on the reader bracket N. This reader can be adjusted by loosening two screws in its rear surface and moving it to one side.

The *Mark II* differs from the *Mark III* as follows:—

- (1) The dial plate is not cast with two lug pieces on it.
- (2) The slope of the dial plate is steeper, which causes the reader plates to be slightly lower.
- (3) The boss on the top of the dial plate is slightly smaller in diameter, necessitating a smaller clamping collar and lead lining.
- (4) The vertical scale graduations on the upper prism holder crosshead and the micrometer head, excepting the zero and index marks, are omitted.

Mark I.—The *Mark I* sight differs from the *Mark II* in the following particulars:—

One of the milled heads on the worm spindle is smaller.

A vertical scale, with graduations to 15° elevation and depression is fixed to the upper prism holder and the micrometer scale drum is graduated in intervals of 10 minutes.

Certain internal parts are of steel instead of bronze.

Marks I and II sights are brought up to *Mark III* type when passing through Woolwich for repair.

SIGHT, DIAL, NO. 1, MARKS I* AND II.

(Plate XXVII.)

The dial sight consists of a circular carrying plate with degree scale ring, a crosshead and pin and a sight plate with pointer. The carrying plate is hinged at the centre to the crosshead and the crosshead is hinged transversely to the crosshead pin. This arrangement admits of an adjustment right or left to compensate for any difference that may occur in level of the wheels and for elevation or depression being given to the plate and sight. The degree scale ring is fixed to the periphery of the carrying plate by screws; it is marked in degrees (white on black for right side and black on brass for left), 180 on each side of zero, the required angle being read by

means of a pointer fixed to the rear end of the sight plate. Should it be found, by examination, that when the sight line and axis of the howitzer are parallel, zero is *not* indicated, the pointer is so formed as to admit of the required adjustment being made. The sight plate is pivoted to the centre of the carrying plate and jointed near its centre; the joint pin is provided with a thumb nut for clamping the plate in the extended or folded position; the plate is fitted with an acorn-pointed fore-sight at the front end and notched to form a hind-sight at the rear end. A clamping screw is provided to fix the sight plate at the required angle. The sight is fixed to the bracket by the crosshead pin, which fits into a corresponding socket in the supporting pillar and is secured by a keep pin.

When not in use the dial sight must be kept in the leather case provided on the right side of the saddle.

TESTING AND ADJUSTING SIGHTS.

Any adjustment required to optical arrangements must be carried out by an armament artificer.

(1) *To Test the Range Drum.*—Lay the howitzer horizontal by means of a clinometer known to be in adjustment. Set the sight gear on stops. Range drum should be reading zero; if not, adjust as follows:—

Adjustment.—Slacken the screws securing the retaining plate, revolve drum to zero and re-clamp.

(2) *The bubble of the cross-level should be in the centre of its run when the top of the sight is level transversely.*

Test.—Place a clinometer set at zero across the top of the dial sight carrier (having first removed the dial sight) and bring the bubble of the clinometer to the centre of its run by working the cross-levelling gear. The bubble of the cross-level should now be in the centre of its run; if it is not so, then it must be adjusted by an artificer.

(3) *The bubble of the sight clinometer should be in the centre of its run when set at zero, with the howitzer laid horizontal and range drum also at zero.*

Test.—Place a clinometer set at zero on top of the clinometer plane of howitzer and bring the bubble to the centre of its run by working the elevating gear of the carriage. Set sight clinometer and range drum at zero. Place the clinometer, still set at zero, on the top of the carrier of the dial sight; its bubble should be in the centre of its run. If it is not so, adjust by the screws of the sliding block at the front end till the bubble is in the centre of its run.

NOTE.—This adjustment should seldom be required and should only be made by a qualified artificer.

The bubble of the sight clinometer should now be in the centre of its run; if it is not, adjust as follows:—

Adjustment.—Bring the bubble of the sight clinometer to the centre of its run by working the milled head. Slacken the screws securing the reader of the degree scale and the nuts securing the micrometer scales, shift reader and micrometer scales to zero and re-clamp.

ALIGNMENT TESTS.

Before carrying out the alignment tests the carriage should be placed on a firm platform, or on hard level ground and manipulated until the howitzer is level transversely. If these arrangements cannot be conveniently made, the base line of the target testing sights, if used, must be set parallel to the slope of the wheels.

(1) *To ascertain if the lines of sight through the open sight and dial sight are parallel to the bore as regards elevation.*

Test.—Set the range drum of the rocking-bar sight and the gear rocking the upper prism holder of the No. 7 dial sight at zero. Select a clearly defined object at least a mile away; fix cross lines at the muzzle and using the axial vent as a sighting hole, lay the bore on the distant object accurately for elevation by means of the elevating gear. The lines of sight through the open sight and dial sight should fall on the same distant object; if they do not, then adjust in following order:—

Open Sight.—Slacken the clamping nut at the bottom of the foresight and screw the latter up or down till the line of sight is on and re-tighten clamping nut.

No. 7 Dial Sight.—Revolve the milled head at the top of the sight till latter is on. Slacken the nut securing the micrometer collar, revolve the latter to zero and re-clamp. The arrow on the side will not now be quite opposite zero and if confusion is likely to arise, it should be erased and a new one scribed opposite the zero mark.

NOTE.—After carrying out the above adjustment the sight clinometer must be re-tested.

(2) *To ascertain if the lines of sight through open sight and dial sight are parallel to the bore as regards line.*

Test.—Set range drum of the rocking-bar sight at zero and deflection gear of dial sight carrier at 25-minutes left deflection. Set the deflection gear of the rocking-bar sight to the red mark on the scale (true zero) and lay the bore on the distant object accurately for line. The lines of sight through open sight and dial sight should be on the distant object; if not, adjust as follows:—

Open Sight.—Slacken the clamping nut at the bottom of pivot of sight bar and nuts of cotter pin. Ease the cotter slightly and by means of a spanner, turn the eccentric bush until the sight is on and re-clamp.

Dial Sight.—Bring the dial sight on to the distant object by the deflection gear of the carrier. Slacken the screws securing the reader of degree scale and nuts of micrometer scales, shift the reader and scales to 25-minutes left and re-clamp.

Should a distant object not be available, a target must be constructed, as shown in Plate XXVIII and set up 50 yards in front of muzzle. Then with the bore laid on B, the open sight and dial sight must be adjusted on S and D respectively both for elevation and line.

HANDBOOK OF THE B.L. 6-INCH, 26-CWT., MARK I HOWITZER ON
MARK I TRAVELLING CARRIAGE, 1919.

Amendment.

Page 32.

After last line on page, add the following :—

“ *Test of Sight Operating Gear.*

(“ NOTE :—The sight should occasionally be tested for wear of the link motion.)

“ Having carried out Test 1 on page 31, lay the howitzer at 15 degrees elevation with a field clinometer ; bring the bubble of the sight clinometer to the centre of its run by the range handwheel. The range drum should read 15 degrees. If it does not, note the reading. Repeat this procedure at 30 degrees elevation.

“ If the error at 15 degrees exceeds 5 minutes, or if at 30 degrees it exceeds 15 minutes, the sight and sight operating gear should be sent to Ordnance Workshops for repair.”

PART IV.

LIMBER.

(Plate XXX.)

Frame.—The limber consists of a frame which comprises four futchels of flanged steel, connected by a trough-shaped splinter bar in front and by a plate in the centre and rear. To the back of the centre futchels is riveted a steel limber hook (No. 38), with feathered key. Each centre futchel is connected to the splinter bar by a round diagonal stay.

Axletree and Wheels.—The axletree (No. 251) is of tubular steel, with second-class "C" pattern arms. It passes through bearings formed in the futchels and is held in position by brackets, one on either side, which are feathered to the axletree shoulders and bolted to the outside futchels. The brackets are fitted with dust excluders similar to those described for the carriage.

The outer end of each arm is fitted for a lynch pin and an adjusting collar, which has a number of recesses (through which the lynch pin passes) cut in one face; the recesses are of varying depths, from 0·2-inch to 0·5-inch, increasing by 0·05-inch, so that any reduction in the length of the pipe box, due to wear, may be adjusted.

The wheels are second-class "C" pattern, No. 45, Mark III, of double-spoke construction, 4-feet 8-inches in diameter, with a 3-inch steel ring tire, removable P.B. pipe box, 2 steel flanges, 12 spokes and 6 fellocs.

The nave consists of two flanges of corrugated steel, which are connected by bolts. The inner flange is fitted with a steel ring to strengthen it and the outer flange with a centring ring. The pipe box passes through the centre of the flanges and is secured by a nut, which is prevented from working loose by a flat spring, which is fixed to the outer flange and engages with one of a number of ratchet teeth on the rim of the nut. For future manufacture, the spring and ratchet teeth will be replaced by a locking plate, which fits over the octagonal nut and has two arms, through which it is bolted to the flange, the nave bolts being used for this purpose.

A dust cap is screwed on the outer end of the pipe box; it encloses the adjusting collar, lynch pin and the end of the axletree arm. The inner face of the cap is recessed for the reception of a corresponding projecting ring on the nut, the cap being secured to the nut by a split keep pin.

The pipe box is provided with a lubricating hole, which is closed with a $\frac{1}{2}$ -inch screw.

The drag washer is free to revolve round the nut and is secured by the dust cap.

Limber Box.—The limber box is of deal and is bolted to the top of the futchels in rear. The lid, which is covered with canvas, is hinged to the front and secured in rear by a hasp and turnbuckle.

The top of the box is fitted with guard irons and blanket straps. There are also fittings at the sides and ends to take a felling axe,

shovels, &c. Hand leathers, and also clips for two rifles, are fitted to the front of the box.

The box is fitted internally with trays and partitions to carry tools, spare packings, &c. (see page 35).

Fittings for Draught.—The splinter bar is fitted to take a No. 2 connector for traction draught, which is the normal method of transport.

The *No. 2 Connector* is V-shaped, with a draught bolt fitted at the apex for connecting to a tractor and with lugs at the forked ends for attachments to the loops on the futchels. The draught bolt is fitted with a volute spring. The spring is retained between the apex of the V-shaped link and a bearing plate by two collar stays and the bolt which passes through the spring, link and bearing plate. An eye is formed at one end of the draught bolt for attachment to a tractor.

In addition, a staple for a No. 19 pole, with No. 4 pole bar for horse draught, is fitted between the centre futchels at the front and a socket for the end of the pole is fitted between them just in front of the axletree.

The splinter bar is fitted with draught hooks for the No. 12 swingletrees and to enable quadruple horse draught to be used, outriggers for the swingletrees of the two outside horses, are hinged to each end of the splinter bar. When in use the outriggers are braced by a stay connected to the loop of the dragwasher.

Note.—Limbers issued in future will be without fittings for horse draught.

STORES CARRIED IN LIMBER BOX.

Articles.	No.	Remarks.
Bit, vent, 14-inch	1	
Box, obturator	1	
Funnel, filling cylinder, No. 3	1	
Gauge, pressure, No. 5, Mark I	2*	
Measure, filling, hydraulic buffer, No. 1... ..	1	
Pins, keep, split sets	1	In tin box.
Screwdrivers, G.S., 6-inch	1	
" adjusting sights, No. 1	1	
Spanner, No. 1	1	The details of uses of these spanners are given in an Appendix to the M.S. Table.
" No. 2	1	
" No. 3	1	
" No. 4	1	
" No. 5	1	
" No. 6	1	
" No. 11	1	
" No. 12	1	
" No. 14	1	
" No. 23	1	
" No. 93 } (wheels) {	1	
" No. 189 } {	1	
Spanners, adjusting sights { No. 1	1	
{ No. 2	1	
{ No. 4	1	
Tommyies { No. 1 (for use with spanner No. 1, &c.)	1	
{ No. 2 { " spanners Nos. 11 & 12)	1	
{ No. 3 { " spanner No. 13)	1	
Tool, withdrawing split pins	1	
Wrench, breech mechanism, No. 137	1	
" " " No. 138	1	
CARRIED IN TRAY NO. 1.		
Box, spare springs, washers, &c.	1	
Buffer, hydraulic :—		
Packings sets	2	
Rings, compressed packing	2	
Springs, gland	1	
Gear, elevating and loading :—		
Springs, plunger { L.H.	1	
{ R.H.	1	
Recuperator :—		
Packings sets	2	
" plaited hemp, for air valve spindle (in tin)	1	
Rings, compressed packing	2	
Springs, gland	1	
" piston	1	
" throttle valve	1	
CARRIED IN TRAY NO. 2.		
Adapter, oil filling	1	
" pressure gauge	1	
Spanner, No. 13	1	

* Includes 1 spare per battery.

LIMBER, B.L. 6-INCH 26-CWT. HOWITZER.

PACKING OF LIMBER BOX.

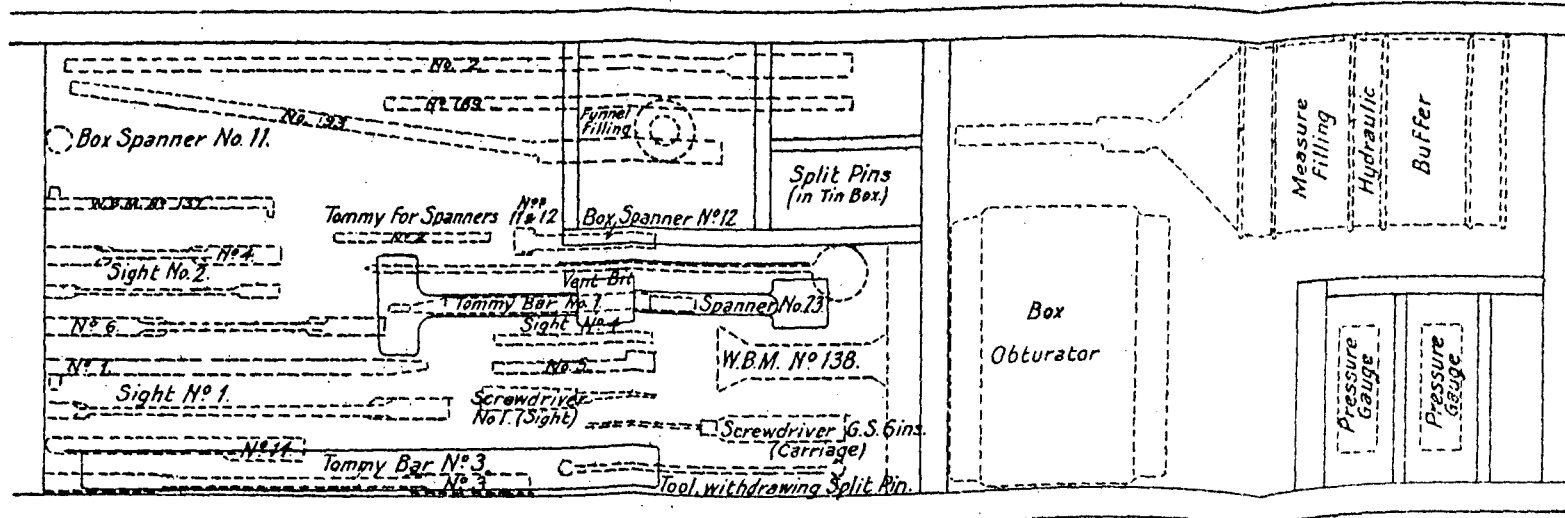

TRAY N° 1.

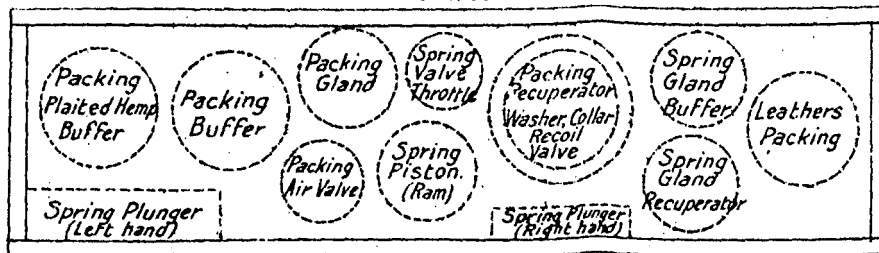

TRAY N° 2.

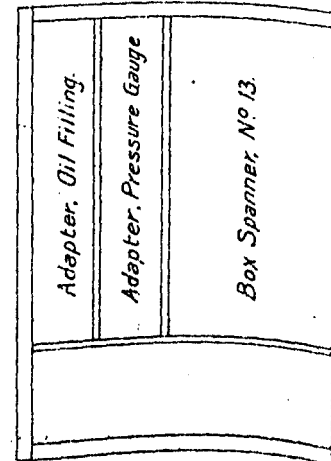

PART V.

CARE AND PRESERVATION.

HOWITZER AND FITTINGS.

The breech fittings and also the projections on the exterior of the howitzer which form guides for the latter when sliding in the cradle of the carriage should be kept clean and oiled or greased and maintained in good working order; all working surfaces must be well lubricated, the fittings being taken off periodically for this purpose.

The threads of the breech screw should be free from burrs; should the screw not work easily when the obturator has been detached, the defect may often be remedied by careful filing, but no portion of the thread should be cut away to remove a crack, &c.

The breech should be kept covered up when possible to prevent dust and grit getting into the interstices of the breech fittings, which might impede their easy working. A cover is provided for this purpose.

The lubrication of the gun-slides is automatic and only takes place when the howitzer recoils on firing. As occasion offers, therefore, the lubrication of the slides should be attended to so as to make sure that they are always well lubricated and that there is sufficient lubricant in the recesses in the side cover plates.

The obturating pad should be examined to see that the canvas or wire covering is intact and in proper order for use. If the cover is found to be loose, or to overlap either of the protecting rings, the obturator should be exchanged.

The spare pad will be kept under compression in the "box, obturator."

The protecting and adjusting discs and steel rings should also be carefully examined and if the discs be fuzed, or the steel rings eroded, burred, or cracked, should be replaced by new.

When fitting the pad and discs on the vent axial, care must be taken that they are in correct order. The face of the pad marked "front" should be towards the muzzle. One or more steel adjusting discs may be required between the obturator and the face of the breech screw when the pad is compressed by firing, but the obturator should always turn freely.

The obturating pad should be a close fit in the coned seating in the howitzer when the breech is closed.

In order to ascertain this, slightly cover the seating with grease (a mixture of oil and tallow), then close and open the breech, the outer end of the pad should now be covered with grease from contact with the greased seating in the howitzer. When it is found, after the above test, that the pad does not fit the seating closely, adjusting discs should be added until the breech closes tightly and with some difficulty. The breech should then be opened and closed until the pad of the obturator becomes compressed. Before use, the pad and discs should be well covered with tallow.

Every opportunity should be taken to keep the obturator and vent axial cool. This can be done by pouring water over it in position, or by sousing it thoroughly with the sponge during or after firing.

After a long, rapid, firing series, the vent head becomes exceedingly hot and the pad very soft; when this is the case, it should be thoroughly soused with water before taking apart.

When a new pad is brought into use it should be expanded with a full charge.

CARRIAGES, &C.

Cradle.—The guideways on the cradle in which the howitzer slides should be kept clean, free from burrs and well lubricated.

Elevating Gear.—To be kept clean, well lubricated and the teeth of pinions and wheels greased. If there is any play in the gear it should be taken up by manipulating the adjusting bush at the front end of the worm spindle.

Traversing Gear.—To be kept clean and well lubricated. Any play in the gear must be taken up by screwing up the adjusting nut.

Brake Gear.—Must be kept clean and well lubricated. When girdles are employed on the wheels the brake arms must be disconnected and the actuating rods and arms housed into the sides of the trail. If the brake gear is taken to pieces for any purpose, care must be taken in assembling, that the arrows on the rod and keyed sleeve are in coincidence.

Cradle Clamp.—Must always be used when travelling to prevent any strains coming upon the elevating, quick-loading and traversing gears. Before connecting to the cradle it should be seen that the traversing indicator is at zero and that the plunger of the quick-loading gear is withdrawn from its recess in the elevating arc, with the pawl of the cradle clamp engaging the hand lever of the quick-loading gear.

Wheels.—The grease chambers inside the pipe boxes must be kept full of grease. When it is required to replenish them the carriage or limber should be raised and the wheels removed. The axletree arm and the interior of the pipe box should be thoroughly cleaned and fresh lubricant supplied.

With the No. 45 wheels, used with the limber, should they complain while on the line of march, the lubricating screws should be removed and oil poured in, but at the first available opportunity the wheels should be removed and lubricated as above.

Wear in the direction of the length of the pipe box must be taken up by removing the dust cap and linch pin, turning the adjusting collar round to a shallower slot and replacing linch pin and dust cap.

Shrinkage in the feet of the spokes must be taken up by tightening up the nuts of the nave bolts and in the case of the No. 45 wheel, following up with the nut, pipe-box.

Hydraulic Buffer and Recuperator.—Before firing, careful attention should be given to the following points:—

- (i) That the hydraulic buffer is correctly filled and that the correct quantity of reserve oil is in the tank, where fitted.
- (ii) That the recuperator is correctly charged with both liquid and air.
- (iii) That there is no leakage at the stuffing boxes.
- (iv) That the cylinder block is securely nutted up to the howitzer lug and that the piston rod of the buffer and ram of the recuperator are properly secured to the front cap.
- (v) That the cut-off gear is in correct adjustment.
- (vi) That all gears and working surfaces are clean and well lubricated (for list of lubricating holes *see* page 52).

WARNINGS.

A.—Before removing the front cradle cap steps must be taken to prevent the howitzer from slipping back, either by lashing it firmly to the cradle or by placing a bar through the holes in the rear of the cradle and interposing a wood block between the bar and howitzer.

Similar precautions must be taken should it be necessary at any time to empty the system of air pressure.

If the cradle cap is to be left off for a long time, the elevating handwheel should be taken off.

B.—On no account must oil be added to the recuperator after filling. Should sufficient oil have been lost to reduce the pressure below 450-lbs. per square inch, the recuperator must be completely emptied and refilled.

C.—Every care must be taken to lay and maintain the cradle perfectly level in order to ensure correct filling (*see* Figs. 1 and 2). This is very important as, with the cradle elevated only half a degree three pints and, with one degree, five pints, too much oil can be put in before it will overflow at hole "D." (*see* Figs. 3 and 4).

D.—Care should be taken to see that plugs are removed from both holes "D" and "E" as, if either is left in when filling and the cradle is not level crosswise, too much oil may be put in and cause serious damage to recuperator (*see* Fig. 3).

NOTE.—Hole "E" is now being made larger (*see* Fig. 1) in order to assist in correctly filling the recuperator.

E.—The greatest care must be taken to see that the recuperator is correctly filled as too much oil may cause serious damage and put the howitzer out of action. When properly filled the recuperator should contain 28-pints of oil and this amount must never be exceeded.

F.—It is essential that the oil used in the buffer and recuperator should be clean and free from grit, as sand and grit will cause damage to the working parts. The oil should be strained before use.

G.—If the cradle cap is removed and the recuperator is charged with air the securing collar of the recuperator ram must on no account be removed without first releasing the air pressure. The collar bears against the stuffing box cap and prevents the ram from being forced out to the rear when under pressure and disconnected from the cradle cap.

H.—Should it be necessary at any time to remove from either H.P. cylinder the front end plug which contains the hole and plug "D" or "E," care must be taken to see that both holes are practically on the vertical centre line in the bottom position (*see* Fig. 5) when the plug is replaced and the joint made tight.

I.—It is important that the buffer should be kept full when in action, as a buffer only partly full means a violent recoil and a wrecked carriage. The tank, where fitted, should therefore be kept full, the howitzer elevated slightly from time to time and the snifting valve operated, for if there is any air in the buffer oil cannot flow from the tank until the air is expelled. Should the tank or connecting pipe be damaged so as to render them unserviceable, the isolating valve at rear end of the connecting pipe should be screwed down tight (*see* Fig. 8).

J.—Great care should always be taken, when replacing the front plugs, stuffing boxes, &c., after any of them have been removed for any purpose, that the locking plates with which they are provided are also replaced.

K.—During severe weather, buffers and recuperators should be protected as much as possible from the cold by covering them with sand bags, sacking or straw, &c. and when possible, by keeping gun pits warm by means of braziers or stoves. If this is done oil should be efficient at temperatures down to 0° F.

L.—Care must be taken that the wood depression stop is always in place as shown in Fig. 9.

The wood block is provided to stop the cradle at the loading angle (7½° elevation) and to relieve the locking bracket on the right side of the saddle of the shock of bringing howitzer and cradle to rest.

If the wood block is not in the position shown damage may be caused to the loading gear brackets.

It should never be moved from this position except for firing below 7½° elevation, or when requiring to fill or empty the hydraulic buffer or recuperator as indicated in the following pages.

Fig. 1.

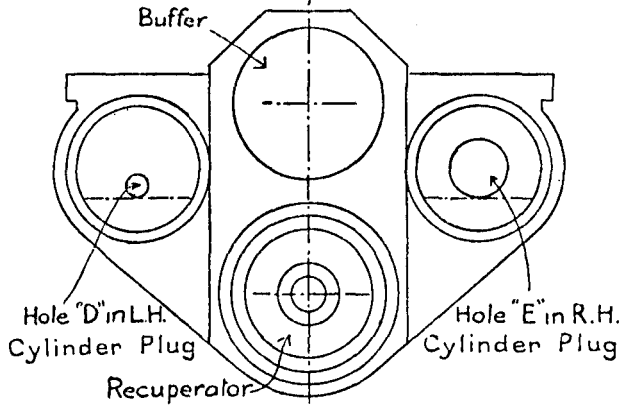

Recuperator fitted with Plug E of large diameter (1 7/8 ins.) in R.H.H.P. Cylinder.

Sectional view, looking from Breech to Muzzle, showing Recuperator level crosswise and oil at correct level.

Fig. 2.

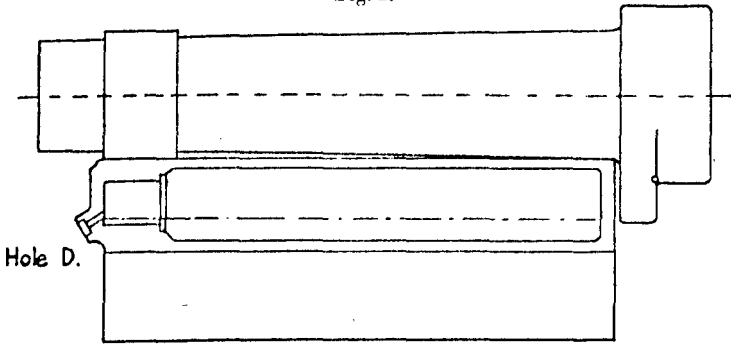

Recuperator level lengthwise and oil at correct level.

Fig. 3.

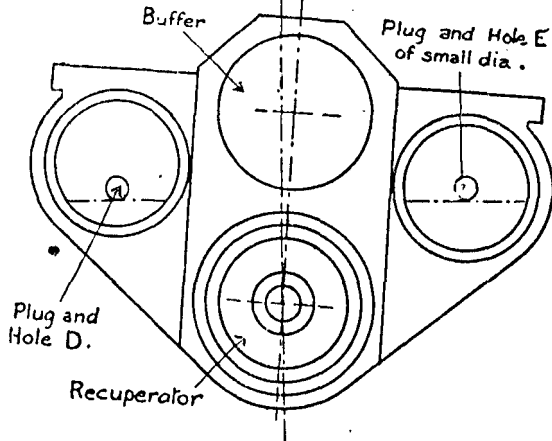

Recuperator out of level crosswise, causing dangerous excess of oil. Sectional view, looking from Breech to Muzzle, showing Recuperator fitted with original size of Plug E. (1/2 in. diameter).

Fig. 4.

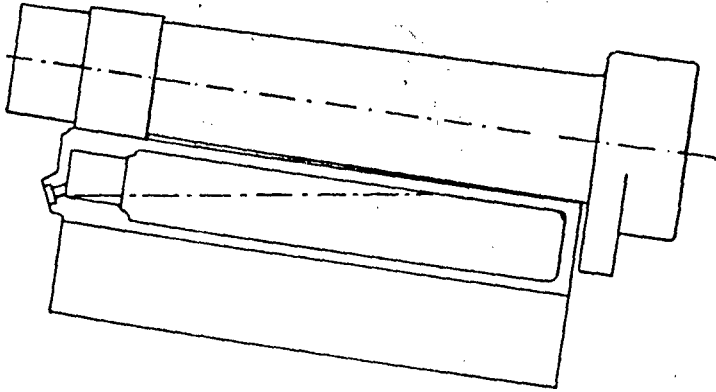

Recuperator out of level lengthwise, causing dangerous excess of oil.

Fig. 5.

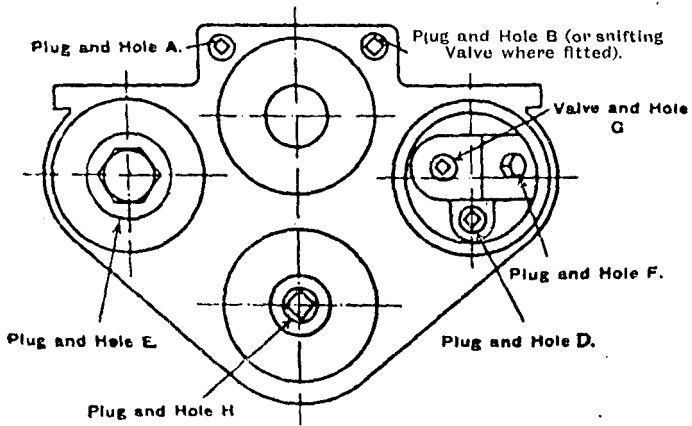

Recuperator front end, showing Filling-Holes.

Fig. 6.

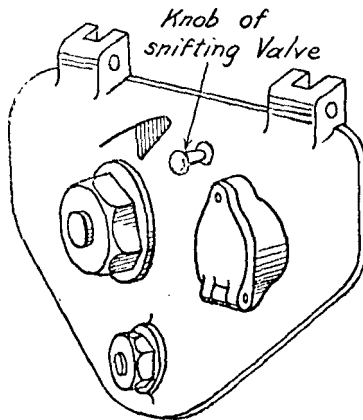

Fig. 7.

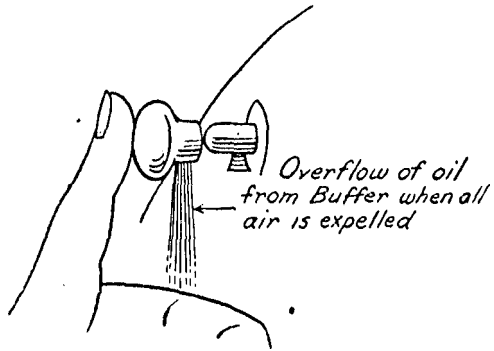

Fig. 8.

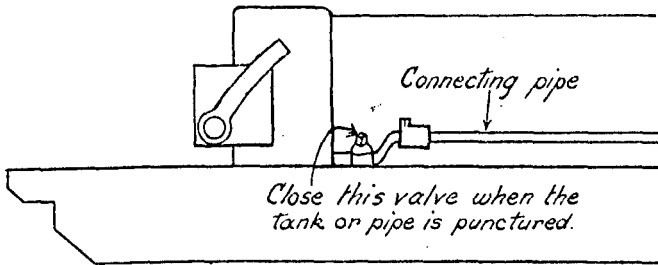
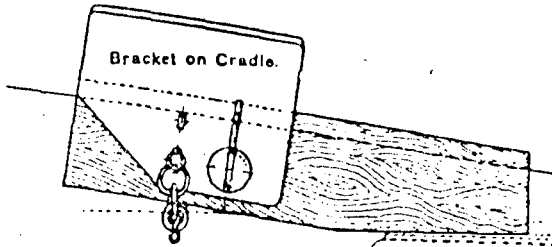

Fig. 9.



Depression Stop.

Cradle elevated to 7 ft. 30 ins. Stop (wood block).

To charge the recoil system.—This should be carried out in the following order:—

1. Charge recuperator with oil.
2. Charge H.P. cylinders with air.
3. Fill the hydraulic buffer.

RECUPERATOR.

To charge recuperator with oil:—

- (a) Lash howitzer to cradle; remove depression stop; disconnect cut-off gear and remove front cradle cap (*see* WARNING "A").
- (b) If the system has been charged with air remove plug "F" and open valve "G" to release air pressure.
- (c) See the recuperator is quite empty before commencing to fill (*see* WARNING "B"). For method of emptying (*see* page 49).
- (d) Set cradle horizontal, longitudinally and transversely, to a clinometer known to be in adjustment (*see* WARNING "C" and "D").
- (e) Remove plugs "D" and "E," also plug "H" (*see* WARNING "D").

NOTE.—The plug and hole "E" in the right H.P. cylinder are now being made of larger diameter, with hole "E" concentric with the cylinder, but the bottom of the hole level with the bottom of the hole "D" in the left H.P. cylinder, as before (*see* Fig. 1).

- (f) See that bucket of the liquid pump is empty, and then measure in exactly 29 pints of service buffer oil (*see* WARNING "E" and "F").
- (g) Attach pump connection and adapter oil filling at hole "H" and pump in oil till liquid overflows at holes "D" and "E" which should occur when the pump begins to draw in air with the oil. One pint of oil will then remain in the bucket and pump barrel, being below the pump suction level. Remove pump connection and adapter and replace plug "H" quickly to avoid losing oil.
- (h) Replace plugs "D" and "E" and cradle cap, taking care to see that the securing collar is on the ram with the locking stud in the correct position to engage between the pegs on the inside of the cap, secure piston rod and ram to cradle cap. Connect up cut-off gear and replace depression stop.

To make up liquid to correct quantity after leakage.—If the quantity of liquid lost is sufficient to reduce pressure below the minimum working pressure of 450-lbs., the recuperator must be completely emptied and refilled (*see* WARNING "B").

To charge recuperator with air :—

- (a) Before charging recuperator with compressed air see that it is filled with the correct quantity of liquid.
- (b) If the cradle cap is not in position it is very important to see that the securing collar is on the recuperator ram. The collar bears against the stuffing box cap and prevents the ram from being forced out to the rear when under pressure and disconnected from the front cradle cap. Care should be taken during pumping to see that the collar bears only against the stuffing box cap and not on the gland sleeve (see WARNING "A").
- (c) If the front cradle cap is in position care should be taken to see that the piston rod of buffer and ram of recuperator are properly nipped up to the cap.
- (d) Attach air compressor to clips on trail and connect up copper piping to the delivery fitting of the compressor. (For instructions for working the air compressor, see page 54.)
- (e) Remove plug, adapter hole "F" and attach pressure gauge adapter with pressure gauge in position.
- (f) Remove cap from adapter, pressure gauge and connect up pipe from air compressor, taking care to see that all joints are properly screwed up.
- (g) Open valve "G" and pump up until pressure gauge registers 600-lbs. per square inch.
- (h) Close valve "G" and disconnect compressor pipe from adapter and replace cap on adapter.
- (i) Open valve "G" and verify pressure.
- (j) Close valve "G" and tighten lock nut till it just grips. Remove adapter and pressure gauge and replace plug, adapter hole "F."
- (k) If not already in position, replace front cradle cap, nuts securing piston rod and recuperator ram and connect up cut-off gear.
- (l) Remove howitzer lashings.

To test the air pressure.—Lay howitzer level and swing door of cradle cap clear. Remove plug "F" from adapter hole in right H.P. cylinder and place adapter pressure gauge in position, blanking one end by the adapter cap. Attach pressure gauge to adapter, open valve "G" and gauge should register 600-lbs. per square inch. If it does not, more air must be pumped in as described under "*To make up air pressure after leakage.*" If correct, close valve "G," remove adapter with pressure gauge and replace plug "F." Replace door of cradle cap.

If, on examination, it is found that the pressure is between 450-lbs. and 600-lbs., it is not considered necessary to interfere with the liquid but simply that the air pressure should be raised up to 600-lbs. and only when pressure has fallen below 450-lbs. should the recuperator be emptied of both air and liquid and recharged.

To make up the air pressure after leakage.—Proceed as for charging recuperator with compressed air but before opening valve “G” to admit air into H.P. cylinder pump the pressure up to 600-lbs. per square inch in the pipe.

To tighten the glands.—Proceed as described under this head for “*Hydraulic Buffer*,” page 47.

To replace fibre packing washer in stuffing box.—The system must be emptied as described under “*To empty the Recoil System*,” on page 48, the defective washer may then be replaced by new, the fittings replaced in the reverse order and the system recharged. Opportunity should be taken to examine the L-rubber and also the compressed packing ring to see that they are in good working order.

To replace L-rubbers, compressed packing ring, glands, gland sleeve, butt ring or gland spring.—The system must be emptied as described under “*To empty the Recoil System*,” on page 49. The procedure is then similar to that given for the replacement of those parts under “*Hydraulic Buffer*,” page 48.

To replace centring collar, throttle valve, or throttle valve spring.—The system must be emptied as described on page 49, under “*To empty the Recoil System*.” The valve spring, throttle valve, or centring collar can then be drawn off the recuperator ram and replaced by new.

To replace the ram packing.—If during the run-up of the howitzer it is noticed that liquid is forced out through the holes in the dust cap at the rear end of the liquid cylinder, it denotes that the packing on the ram has become defective and, if the leakage cannot be prevented by tightening up the compressed packing ring, or by the addition of a supplementary packing ring, if not already in use, the packing should be exchanged as follows:—

The recuperator system must be emptied as described under “*To empty the Recoil System*” on page 49. Remove the throttle valve with centring collar and spring. Remove nuts securing cylinder block to howitzer and force howitzer back along the cradle to give clearance in working, supporting the rear end of the cradle if necessary. Remove dust cap and withdraw ram to the rear. The packing should then be replaced by new and the fittings replaced in reverse order. Run up howitzer to firing position and secure to cylinder block by securing nuts. Recharge the system as described on pages 44 and 45.

NOTE.—Before putting in new rubbers, care should be taken to see that they are smooth and clean and free from flaws and grit. They should be oiled all over immediately before assembling with a little of the same oil as is used in the recuperator.

After the recuperator piston is assembled it should be entered into the recuperator cylinder and should be just tight enough to require to be gently tapped with a mallet of about 7-lbs. weight. It must not on any account be so tight as to require to be driven up the cylinder with hard blows. If it will not pass up the cylinder by moderate tapping it should be taken out and examined to see what parts are too tight.

HYDRAULIC BUFFER.

To fill hydraulic buffer not fitted with tank:—

- (i) Lash howitzer to cradle; remove depression stop, disconnect cut-off gear; remove nuts securing piston rod and recuperator ram; remove cradle cap; elevate howitzer about 5 degrees (*see* WARNING "A").
- (ii) Remove plugs "A" and "B," and by means of funnel filling cylinder pour in liquid at "A" till it overflows at "B."
- (iii) Depress howitzer to 5 degrees depression, push piston rod into cylinder as far as possible and allow liquid to drain off.
- (iv) Replace plugs "A" and "B."
- (v) Replace cradle cap and nuts securing piston rod and recuperator ram; connect up cut-off gear.
- (vi) Remove howitzer lashings and replace depression stop.

NOTE.—Quantity of liquid = 18 pints.

To fill hydraulic buffer fitted with tank:—

- (i) The procedure is generally similar to that for filling hydraulic buffers not fitted with tanks (except para. iii), with the following additional instruction.
- (ii) Measure out about 24-pints of oil. This quantity includes 6-pints for the tank and connections.
- (iii) After filling buffer as described above, remove filling plug from tank and pour in remaining oil.
- (iv) When filling is completed, press knob on spindle of snifting valve to allow the escape from the buffer of any air which may have collected (*see* Figs. 6 and 7). (*See* WARNING "I.")
- (v) When buffer is full of oil and all air has been driven out, oil will flow out from knob of snifting valve spindle, if the knob is pressed (*see* Fig. 7).
- (vi) Replace filling plug of tank.

To make up liquid to correct quantity after leakage.—Leakage from the hydraulic buffer is automatically made up from the tank when such is fitted and is in operation, providing there is no air in the buffer, which can be seen by working the snifting valve. The quantity of oil in the tank should therefore be noted from time to time and the correct quantity maintained.

In the case of buffers without tanks, or where the tank is inoperative for some cause, proceed as for charging the hydraulic buffer not fitted with tank as described above.

To tighten the glands.—Lash howitzer to cradle, disconnect cut-off gear, remove cradle cap (*see* WARNING "A"). Tighten the cap of stuffing box by means of the spanner provided, replace cradle cap and connect up cut-off gear.

To replace the fibre washer or steel joint ring.—Lash howitzer to cradle, disconnect cut-off gear (*see* WARNING "A" and "G")

and remove cradle cap. Elevate howitzer to a position convenient for working while retaining as much of the oil as possible in the buffer. Remove stuffing box, catching any oil that may escape in clean receptacles. Replace defective washer or joint ring with new and replace stuffing box. Refill buffer as described on page 47. Replace front cradle cap and connect up cut-off gear, replace nuts securing piston rod and recuperator ram.

To replace the L-rubber rings.—Lash howitzer to cradle, disconnect cut-off gear and remove cradle cap (*see* WARNING “A” and “G”). Elevate howitzer to a convenient height for working while retaining as much of the oil as possible in the buffer. Remove cap of stuffing box and spiral spring. Remove stuffing box together with defective packing, care being taken to catch any oil that may escape in suitable vessels. Remove old packing, insert new and replace parts in the reverse order. Opportunity should be taken to examine the steel joint ring and fibre washer and see that they are in good order. Refill buffer as described on page 47. Replace cradle cap and nuts securing piston rod and recuperator ram. Connect up cut-off gear.

When putting the L-rubbers in the stuffing box see that the flat surface is well bedded down to the metal. If this is not done the joint may leak and cause damage to the stuffing box. See that all parts are clean and free from grit before replacement.

To replace compressed packing ring.—If leakage occurs at the glands and tightening up the caps does not prevent it, a supplementary packing ring must be used or, if a supplementary ring is already in use, the defective packing ring should be replaced by a new packing ring. This should be done as described for replacing the L-rubbers. Opportunity should be taken to see that the L-rubbers are in good order (*see* WARNING “A” and “G”).

The packing ring should be oiled all over with a little buffer oil immediately before assembling. The packing ring should pass over the piston rod with a moderate push. It should not be so slack that it will slip quite easily, nor so tight as to require to be driven, along the rod.

To replace glands, gland screw, gland spring or butt ring.—The procedure for replacing the parts is generally similar to that described for replacing L-rubbers.

TO EMPTY THE RECOIL SYSTEM.

To empty the hydraulic buffer:—

- (a) Lash howitzer to cradle; disconnect cut-off gear; remove depression stop; remove front cap (*see* WARNING “A.”)
- (b) Set cradle about horizontal.
- (c) Remove filling plug from tank (or plugs “A” and “B” where tank is not fitted). Remove stuffing-box and run off oil into clean receptacles.
- (d) Rock cradle up and down a few degrees to ensure draining tank, where fitted and passages of control chamber.
- (e) Replace stuffing box.

To empty the recuperator :—

- (a) Lash howitzer to cradle; disconnect cut-off gear; remove depression stop; remove front cradle cap (*see* WARNING "A").
- (b) Set cradle about horizontal.
- (c) Remove plug adapter hole "F" and open valve "G" and allow air pressure to escape.
- (d) Take off securing collar from ram and remove stuffing box from liquid cylinder and run off oil into clean receptacles.
- (e) Remove plug "H" to ensure draining recuperator ram.
- (f) Rock cradle up and down on trunnions from a few degrees elevation to a few degrees depression to ensure draining H.P. cylinders.
- (g) When certain that no more oil is left in the H.P. cylinders, depress the front end of cradle as much as possible by lifting the trail eye, in order to run all the oil out of the recuperator passages.
- (h) Replace stuffing box, plug "H" and collar securing ram.

POINTS REQUIRING ATTENTION.

Faulty run-out.—Should the howitzer fail to run-out satisfactorily this may be due to one or more of the following causes:—

- (i) Want of lubricating of gun slides.
- ii) Air in buffer cylinder.
- (iii) Incorrect setting of valve adjusting run-out.
- (iv) Weak recuperator.
- (v) Over-tightening of glands.

(i) *Want of lubricating of gun slides.*—*See* under "Care and preservation of howitzer, &c.," page 37.

(ii) *Air in buffer cylinder.*—This may be due to air which, as sometimes happens, has accumulated in the buffer cylinder owing to a small amount of air being sucked into the cylinder through the gland during run-up. Should this be so, press knob of snifting valve to liberate any air that may be held in compression in the cylinder, when the howitzer should move to the firing position.

(iii) *Incorrect setting of valve adjusting run-out.*—Should the howitzer fail to run-out fully after the first round, this may be due to incorrect setting of the valve adjusting run-out situated in the rear of the cylinder block. Open valve, the howitzer should then move to the firing position. If the howitzer then fails to run-out, it should be forced into the firing position and another round fired. If the howitzer again fails to run-out fully or should it remain at full recoil after the first round, the air pressure should be released and the amount of liquid adjusted as described on page 44. The system should then be recharged with air.

The run-out should, under all conditions, be smooth and steady, without hesitation, vibration or bump. The speed of run-out can be

regulated by the valve adjusting run-out which can be adjusted to give an easy run-out at either low, medium or high angles of elevation. Should the howitzer run-out with violence the valve should be screwed down until a satisfactory rate of run-out is obtained. If the howitzer runs out correctly at horizontal or low angles of elevation, it may be found that, with an increase in range, the run-out is too slow, in which case the valve should be opened to the extent found necessary. Similarly, a return to low angles of elevation may result in the howitzer running out with violence. The rate of run-out should, therefore, be watched and, if necessary, slowed down by means of the valve until correct.†

(iv) *Weak Recuperator*.—This may be due to loss of liquid through faulty packings or the loss of air owing to valve "G" not having been properly closed down or the plugs "D" and "E" not being properly screwed in. Every endeavour should be made to ascertain the true cause. The air pressure should be tested and, if necessary, adjusted as described on page 45, or, if the air pressure is below 450-lbs. per square inch, and this is due to loss of liquid, the system should be emptied and recharged (*see* WARNING "B").

(v) *Over-tightening of Glands*.—Glands should be tightened up, if possible, when the cradle is warm, as the packings then compress better. The gland packings should not, however, be tightened up more than is necessary to prevent *excessive* leakage, as endeavours to entirely prevent leakage may lead to undue tightness, thus affecting the rate of run-up of the howitzer and causing excessive wear of the working parts.

Faulty Recoils.—Frequent notice should be taken of the lengths of recoil as shown by the recoil indicator on the left side of the cradle, the cut-off gear being adjusted, if necessary, by disconnecting the eye securing the connecting rod, as indicated by engravings on the eye.

When checking the length of recoil and before any adjustment of the cut-off gear is carried out, the following points should be noted:—

- (a) The length of recoil should be checked after a few rounds have been fired, as, owing to the equipment not having settled down, the recoils for the first round or two may be found below normal.
- (b) As firing proceeds, the length of recoil will, owing to the abnormal resistance set up in the recuperator by the increased pressure resulting from the rise in temperature of the liquid, tend to fall below normal. This tendency will be most noticeable when firing at low angles of elevation, as the proportion of the work done by the recuperator is then greater than that done by the hydraulic buffer, while at the higher angles of elevation the reduction will not be so noticeable, as the proportion of work done is then reversed, *i.e.*, the greater part is done by the buffer.

† Care should be exercised in the manipulation of these and similar valves. These valves should be operated without any additional leverage.

- (e) Should excessive or violent recoils occur, these may be due to (i) a weak buffer, owing to insufficient liquid; (ii) a weak recuperator, through loss of air pressure; (iii) a combination of both (i) and (ii), or (iv) incorrect setting of cut-off gear:—
- (i) See that buffer is full. To ascertain this in the case of buffers fitted with tanks, elevate a few degrees and press knob of snifting valve. If buffer is full, oil will flow out from the spindle actuating the valve. In the case of buffers not fitted with tanks, or where the tanks are inoperative for some cause, proceed as for filling the buffer described on page 47. Where tanks are fitted see that tank is full. The oil level in the tank should never be accepted as an indication of the condition of the buffer, as oil will not flow from the tank into the buffer until all air in the latter has been liberated by operating the snifting valve. The only satisfactory proof of a full buffer is that, with the howitzer elevated a few degrees, oil flows from the spindle actuating the snifting valve on pressing the knob.
 - (ii) If the adjustment of the liquid in the buffer fails to give satisfactory recoil, the air pressure should be tested and, if found to be too low, should be replenished according to instructions given on page 46.
 - (iii) Proceed as in (i) and (ii) above.
 - (iv) To adjust the setting of the cut-off gear, proceed as laid down on Plate XXI.

SIGHTING.

The dial sight when issued is in correct adjustment, watertight and with all the cells and joints secured with fixing screws.

It is very unlikely that the interior will be required to be cleaned and the dial sight must on no account be taken to pieces, except by persons in possession of a certificate from the Ordnance College stating that they are qualified to do so.

The body of the dial sight must be cleaned with a clean soft cloth and a little oil, which must be rubbed off afterwards, care being taken that the glass is not touched.

The exterior of eyelens and window should be cleaned with chamois leather, specially kept for the purpose and only by a competent person, great care being taken that no oil or grease is allowed to touch the glasses. Fingers when apparently clean and dry may leave marks on the lens which will impair the definition of the telescope.

Owing to the construction of the carrier the deflection arrangements should be occasionally tested for backlash by laying on a well-defined object and traversing the sight from right and left alternately by means of the deflection screw until the vertical crossline is aligned. If the deflection scale does not read the same in both instances, the difference of reading indicates the backlash.

Backlash may be due to the small coned portion of the carrier which is removed when inserting the sight in its carrier, having become strained or not fitting properly.

To correct this, the removable portion of the coned surface of the carrier may perhaps be made to fit more perfectly by manipulating its fixing screws. If this fails, the coned surface of the removable portion should be slightly reduced with fine emery paper or a dead smooth file.

When not in use the dial sight in its carrier must be kept in its leather case on the left side of the saddle.

LIST OF LUBRICATORS.

Fitting to be lubricated.	Lubricator.	Position of lubricator.
BREACH MECHANISM.		
Bearing B.M. lever	1	On top side of carrier.
Safety shutter	1	On top left side of carrier.
Carrier hinge joint	1	On top of hinge pin.
Breach screw and pintle of carrier	1	On top side of breach screw.
CARRIAGE.		
Cradle... ..	3	On each side for howitzer slide.
Capsquare	1	On each trunnion.
Quick-loading gear	2	On right spring plunger.
" " "	1	On left spring plunger.
" " "	1	On each side connecting shaft.
Elevating bracket	3	For worm and spindle and arc pinion shaft.
Traversing gear	1	On pivot.
Sight supporting bracket	1	For right pivot.
Elevating arc... ..	1	Over cradle trunnions.
Gear, brake	1	On each side for actuating rod.
" "	1	In each actuating nut.
Cut-off gear	2	In cradle cap.
	1	In trunnion link.
Trail	2	Holding down clips on front.

PART VI.

MISCELLANEOUS STORES.

Apparatus Illuminating Sights No. 1.—This apparatus (*Plate XXXII*) is of torch pattern with two lampholders and is designed to fit in the telescope clips; when fixed in this position, the rigid lampholder should be in a position to illuminate the window of the dial sight No. 7, and the movable lampholder should illuminate the range drum; this latter lampholder may be removed from the clip when illumination of any other portion of the sight is required.

The apparatus consists of a steel tube containing a battery dry torch fitted at one end with a brass knurled cap that can be removed for changing the battery, and at the other end with a switch box and handle for controlling the lamps.

Damp-proof lampholders each containing a bulb electric 3.5 volt are fitted to the switch box, one rigidly and one on the end of a flexible tube. Each of the lampholders is fitted with a reflector and cap containing the glass disc and rubber washer. The cap of the lampholder on flexible tube is fitted with a metal guard to protect the glass. The flexible tube is held in position on the sight by a spring clip secured under the locking nut.

The switch box is fitted with a cover which can be removed if necessary by taking out the screws.

The battery consists of three cells electric dry "T" contained in a cardboard tube. The E.M.F. of the battery in series is 45 volts and the current required for each lamp is .3 amperes.

A later pattern has now been introduced; this is fitted with two C.T. cables, 12-inches and 20-inches long respectively, in the place of the fixed lampholder and the flexible tube and will be known as "Apparatus, Illuminating Sights No. 1, Mark II."

Bit, Vent, 14-inch.—This is of round steel furnished with a spiral bit at one end and hardened at the point; the opposite end is formed into a loop for convenience in handling. It is used for removing obstructions from the vent channel and for cleaning it.

Borer, Vent Axial, .303-inch Chamber.—The borer is of steel, shaped to suit the chamber for "Tube, percussion, S.A. cartridge" in the vent bush spindle of the axial vent. The front end of the borer is serrated for removing obstructions of a hard nature from the tube chamber; the other end of the borer is provided with a cross-handle.

The borer is used with Martini-Metford and percussion lock "P.H." mechanisms.

Box, Obturator.—The box is of wood with metal bolt and fly nuts to hold two obturators and adjusting discs.

Brush, Piasaba, B.L. 6-inch, Howitzer, Bore, Mark III.—This piasaba brush is fitted with a parallel head, consisting of an elm stock to which is attached 8 rows of piasaba tufts, a gunmetal retaining plate, spindle, securing nut with lock nut and socket. The elm stock is retained in position against the socket by the retaining plate and securing nuts; it is prevented from rotating on the spindle during use by a small cheescheaded screw, threaded into the

inner face of the socket and engaging with a recess in the elm stock. The stave is of ash $1\frac{1}{4}$ -inch diameter; it is fitted at one end with a joint for an end stave and is attached to the socket by means of a copper rivet. The overall length of the piasaba brush is 5-ft. 5-in.

Cap, Rammer, B.L. 6-inch Howitzer.—This cap is for use with the rammer when firing A.P. shell. The rammer cap is of manganese bronze, hollow on the face to form a clearance for the base fuze. The rim is 5-inches in diameter of beaded section and reinforced by means of four longitudinal webs. When required for use the cap is secured to the head of the rammer by a “screw, brass, flathead, 1-inch, gauge No. 12.”

Compressor, Air, Portable (Plates XXX and XXXI).—The compressor, which is hand-driven, comprises a No. 2 two-stage vertical air pump, mounted in a stand.

The two-stage air pump consists of the following principal parts:—

- Piston.
- Eccentric (or crank) shaft.
- Two eccentric rods (or straps).
- Gudgeon pin.
- Flywheel.
- Sprocket and chain wheels.
- Water cooled cylinder, with drain hole and plug for emptying purposes when compressor is not required for use.
- Five valves.

The piston is in the form of a double ram. It is connected to the eccentric shaft by means of an eccentric rod fitted at each side of the gudgeon pin. A flywheel is fitted to one end of the eccentric shaft whilst a small sprocket wheel (14 teeth) is attached to the opposite end.

The large (low pressure) suction valve with plug, cap and cover, is fitted horizontally at the bottom of the cylinder.

A small valve, with plug, cap and cover, is also fitted horizontally to the bottom of the cylinder but on the opposite side and opposed to the large valve in action, thus allowing the expulsion of the air drawn in by the low pressure piston.

On the top of the cylinder a bye-pass valve is fitted horizontally and two small valves with caps, plugs and covers fitted vertically; one of the latter allows the passage of the first stage compressed air into the high pressure cylinder and the other the expulsion of the doubly compressed air into the recuperator cylinder of the mounting, through the bye-pass valve.

The *Mark I* stand is of M.B. and is provided with two winch handles, two cranks for winch handles and a winch handle shaft which connects to the eccentric shaft of the pump, by means of sprocket wheels and chain. Two bars are provided for lifting the compressor.

The *Mark II* stand differs from the *Mark I* in being built up of corrugated pressed steel plate riveted together and provided with G.M. bearings for the handles.

Lubrication is effected by means of an adjustable sight-feed lubricator connected by a pipe to the large (low pressure) suction valve; also by the grease cup fitted to each of the two eccentric rods.

CARE AND PRESERVATION.—ALSO RUNNING INSTRUCTIONS.

All gearing, shaft bearings and driving chain must be kept well lubricated and free from dirt and grit as far as possible.

Before starting the compressor to work an outside examination should be made to see that the machine is clean and that no damage has occurred during transit.

The jacket should be filled with water and kept filled while in use; this is most important to prevent over-heating.

The lubricator feeding into the first stage suction valve must be set to feed at the rate of about four drops per minute, and in the case of pumps not fitted with air fitter the cover "37" on the suction inlet should be screwed back three or four turns and the compressor is then ready for use.

If the machine is working in an exposed position during frosty weather and is stopped and allowed to stand for any length of time, the jacket should be drained through the drain plug "35" provided for that purpose. If this is not done the cylinder may be fractured by frost.

When starting up again, if the jacket is empty, do not forget to refill it.

To keep the compressor in good working order, it should be worked daily; half-a-dozen turns of the handles should suffice for this. It should also be kept covered with the cover provided to prevent dust getting into the working parts. This is most important.

The cover is of service colour waterpooof canvas, formed to fit over the compressor, and provided with holes to admit of the use of the lifting bars without its removal. It is secured in position by four lengths of white line lashings passed through brass eyelets.

The working pressure for this machine is up to 600-700-lbs. per square inch, and should there be any falling off of the supply of delivered air the valves should be examined to see if they are clean; if they are found to be gritty the valves and springs should be removed and cleaned. If necessary, grind valves lightly to seats, coat with clean thin oil before replacing. If efficiency of pump is not improved, the piston rings should be examined and compressor head lifted off its base; rings should be taken out of piston grooves and tried in the cylinders. If spring of rings is destroyed the rings should be exchanged. When assembling the parts care should be exercised in seeing that all parts are clean and free from grit.

The joints between main cylinder and base and cylinder cap and cylinder, should be carefully made with brown paper soaked in oil.

Grease cups are provided for the working parts and these should be kept charged with semi-solid grease.

Dismantling and examination can be carried out in the following manner:—

Both the second stage valves are placed in the top cover and are easily accessible by removing the caps "19" and plugs "20."

The first stage suction and delivery valves are placed horizontally and are equally accessible by removing the caps and plugs.

It will be seen that the first stage delivery and the second stage suction and delivery valves, together with their seats, plugs and caps, are interchangeable.

To examine the main bearings in the pedestal, remove the key "33," the flywheel and the split pins and washers from the gudgeon pin "10," when the eccentric straps "6" can be removed from the eccentrics. The eccentrics should then be drawn off the feather keys, the latter removed from the shaft and the shaft drawn out of the bearing.

To withdraw the piston for examination, remove the securing pin "32," draw the gudgeon pin "10," unscrew the four nuts on the bottom flange of the water jacket, when the top part of the machine can be at once removed and the piston drawn out endways.

When charging, it is better to continue running the compressor from start to finish, changing men if fatigued without stopping. Should a stop be necessary the compressor will be much easier to start if the recuperator valve is closed and the bye-pass valve "36" opened on the delivery pipe. In that case, as soon as the compressor is started again, the valve "36" must be closed and the recuperator valve opened.

When the compressing operation is finished open bye-pass valve "36," taking care that the valve on the recuperator is first securely screwed down, also see that suction cover "37" is screwed up hand-tight to prevent dirt getting in.

When compressors are fitted into housings with hand wheels and chains complete, a means of tightening the chain is provided by placing washers underneath the base of the compressor, which washers can be removed and the compressor lowered to the extent of $\frac{3}{16}$ -inch to take up any slack on the chain due to wear or stretching of the same.

The following data is a guide to locating faults:—

If no pressure is obtainable the fault may be due to one of the following causes:—

EXTERNAL FAULTS.

- (1) Release valve open, meshes of wire gauze choked, or in the case of pumps not fitted with filter probably suction cover not screwed back.
- (2) Pipe or adapter joints, cylinder cover, or valve caps leaking.

INTERNAL FAULTS.

- (1) The L.P. inlet or L.P. delivery valves faulty, or valve seat joint defective.
- (2) Packing rings of L.P. or H.P. piston defective, or cylinders scored.
- (3) Air leak into water belt—due to faulty joint.

If pump is not working satisfactorily (with suction cover open), *i.e.*, pressure rising slowly, the defect may be due to any of the above causes. Should the fault occur at high pressure it will be

more probably due to defective H.P. delivery valve, H.P. packing, or scored H.P. cylinder.

Before charging recuperator it is advisable to test the pump system as follows:—

- (1) Close air charging valve on recuperator.
- (2) Work pump slowly till gauge registers 500 or 600-lbs. per square inch.
- (3) If the system is in good working order the gauge hand should now be stationary or only "creeping" back very slowly—the latter being permissible.

Should the hand fall quickly, the system should be examined for external faults; if unable to locate the fault, it may be tested by smearing black wheel grease over joints, when air bubbles will be observable where there is a leak.

NOTE.—Great care should be exercised in using the gauge. When taking or releasing the pressure, the valve should be opened gently in order to prevent damage to gauge.

In all correspondence relating to the machine the number of the machine should be quoted and where spare parts are required the numbers should be given.

Cover, breech.—The cover is of service colour waterproof canvas and is shaped to fit over the breech of the howitzer and the rear end of the cradle. It is secured when in position by means of $\frac{1}{4}$ -inch diameter ropes passed through brass eyelets in the edges of the cover and tied.

Cover, muzzle, No. 18.—The cover is made of double thickness service colour waterproof canvas and is formed to protect the muzzle of the howitzer to which it is secured when in position by a length of $\frac{1}{4}$ -inch diameter rope stitched at the middle to the cover and having a loop formed at one end.

Cover, rocking bar sight, No. 1.—The cover is made of double thickness service colour waterproof canvas and is formed to protect the rocking-bar sight. It is provided with an opening at one side and is secured when in position by a lace of white line passing through brass eyelets fitted at intervals round the edges.

Funnel, Filling Cylinder, No. 3.—The funnel, which is of block tin, is provided with a bent spout to fit into the filling-holes of the buffer and recuperator.

Implements, Ammunition, Key, No. 8 (Mark IV).—Is a steel key with suitable projections formed on it to fit the slots in the Nos. 11, 15 or 16 base fuzes, for inserting or removing purposes, or their corresponding plugs:

Implements, Ammunition, Key, No. 17.—The key is used for fixing the No. 80 type of fuzes.

The *Mark II* key is made of steel, one end being shaped to fit over the fuze; the lower edge of the ring portion is bevelled to suit all marks of fuzes without covers and is provided with a projection to fit the square notch in the flange of the fuze body. The upper edge of the ring is provided with a slot to fit over the projection on the cover when screwing in fuzes with cover.

The *Mark I* key differs from the *Mark II* in the upper edge not being prepared for use with fuzes with cover.

Implements, Ammunition, Key, No. 18.—This key, is for use in setting the No. 80 type of fuzes.

The *Mark II* is made of steel and is similar in shape to the No. 17, but is provided with a prong on its underside to engage with the stud on the lower time ring. It is fitted with a white cotton lanyard.

The *Mark I* key differs from the *Mark II* in the ring portion, being of lesser depth and consequently does not take such a good seating on the fuze.

Implements, Ammunition, Key, No. 19—Fixing No. 82 Fuze.—The *Mark III* key is made of steel, the ends being shaped and provided with projections to suit the flange on the body of the No. 82 time and percussion fuze, one end being used for fixing and the other for removing the fuze from the shell. The ends are marked accordingly.

The key is fitted with a white cotton lanyard.

Implements, Ammunition, Key, No. 32.—This key is alternative to the No. 17, *Mark II*, key, to which it is similar, except that it is double-handed and instead of the projection for fixing the earlier marks of fuzes being formed solid in the key, it is made separately of hardened steel, wedge-shaped, and driven into the key.

It is heavier and stronger than the No. 17.

Implements, Ammunition, Key, No. 36—Setting No. 82 Fuze.—This key consists of a steel bar with a semi-circular end shaped to suit the bottom time ring of the fuze and to show the setting mark. It has a projection in the centre of the semi-circular portion to suit the slot in the ring for setting purposes.

Implements, Ammunition, Key, No. 48.—The key consists of a plain bar of steel, 10-inches long, $\frac{3}{4}$ -inch wide, having the ends slightly rounded off. It is for use in removing or inserting plugs having suitable slots, also with the slotted cap of the fuze T, Nos. 183 and 188M.

Implements, Ammunition, Key, No. 53—2-inch Percussion or Graze Fuzes.—This key is for use in lieu of the No. 16 Key with 2-inch percussion or graze fuzes and for Adapter, 2-inch fuze-hole No. 2.

Each end is semi-circular in shape with the inner edge chamfered and a projection formed to engage in the slot provided for the purpose.

Lanyard, Firing, No. 33.—The No. 33 firing lanyard is of flexible steel wire rope, 6 feet long, with steel wedge fork and toggle. Two studs are provided in the side of the fork which also serves as a tool in assembling and dismantling the striker spindle. This firing lanyard is for use with percussion lock, "P.H." mechanism.

Lanyard, Firing, No. 35.—The No. 35 firing lanyard is made of hemp rope, 57-inches long, with steel firing peg, loop and wood toggle. The firing peg is of round steel, having a loop formed on one end for the attachment of the lanyard. This firing lanyard is for use with the Martini-Metford percussion lock.

Mat gun wheel.—The mats are made of $\frac{3}{8}$ -inch diameter cane wicker interwoven with ribs of cane or other suitable wood and reinforced longitudinally at intervals by two-strand galvanized wires. The ends of the mats are sheathed with No. 22 S.W.G. steel plate secured by steel bolts.

Measure, Filling, Hydraulic Buffer, No. 1.—This measure is of tin and holds 1 gallon. There are ribs round the inside surface, by which 1-quart, 1-pint, $\frac{1}{2}$ -pint and $\frac{1}{4}$ -pint may be measured. The lower end is provided with a spout and fitted tap. It is fitted inside with a wire gauze strainer.

Press, Obturator; Gauge, Thickness, Obturator; Tommy, Press, Obturator.—The press and gauge are intended for use in re-forming obturators which have become so distorted as to cause difficulty in placing them in position on the axial vent in the howitzer.

The press consists of a steel body, shaped internally to suit the contour of the obturator and fitted with a steel cover. The cover is secured by means of a steel bolt with disc spring washer and cross-handle. The bolt is provided with a square head by means of which the press can be held in a vice while the cross-handle is revolved when compressing or releasing the obturator. A steel tommy is provided for use with the cross-handle in compressing the obturator. Recesses are formed round the periphery of the press so as to admit of the application of the gauge for testing the thickness of the obturator while under compression.

The gauge is of flat steel plate and is for use in testing the thickness of the obturator.

Pump, Liquid, Portable, Mark I.—This pump is used to charge the recuperator with liquid. It consists of a cylindrical galvanized iron bucket provided with a lid. There are brackets inside the bucket, in which the pump is secured by a bayonet joint. The pump proper consists of a vertical cylinder divided into two chambers, in one of which works a packed plunger actuated by a grip handle at the top. The lower end of the pump is perforated for the entrance of liquid, which enters into the plunger chamber through an inlet valve. The bottom of the second chamber is fitted with a delivery valve and its top end has a screwed delivery nozzle, to which is attached a length of flexible hose, which connects the pump to the recuperator ram.

Rammer.—This is made of wood and consists of an elm head with removable ash stave. A white band 2-inches wide should be painted locally on the rammer stave to denote when shell is properly rammed home.

The Mark I differs from the Mark II in being made in one piece.

Rimer, Vent, Axial, 303-inch Chamber Nos. 1 and 2.—The No. 1 rimer is of bronze and steel, the bronze portion being shaped to suit the chamber for "Tube, percussion, S.A. cartridge."

The No. 2 rimer which is generally similar to the No. 1 rimer described above, but without the double joint on the shank, can be used with the percussion lock "P.H." firing mechanism in lieu of No. 1.

Sling, housing rear draught link.—The sling, which is for housing the rear draught link when not in use, is of steel wire rope, provided

at one end with a thimble and at the other with a spring swivel hook and thimble.

Slings, Projectile.—The sling, which is designed to carry one projectile, is for use in place of boxes when transporting shell in carts and wagons.

It consists of four wood battens, braced together by two bands of webbing. A handle and base are formed by webbing fixed to the web bands. A short length of line is provided to secure the projectile in the sling.

Stave, End, No. 17.—This is for use with the piasaba brush; it is of ash, $1\frac{3}{4}$ -inch diameter and is fitted with a metal joint. Length, 4-ft. $7\frac{1}{2}$ -in.

Tray, Loading.—A steel trough-shaped loading tray supported on a framework which is fitted with two bearers is provided. The front end of the tray is shaped to enter the breech opening and so protect the screw threads while ramming home the shell and is fitted with a stop on its underside. The underside of the framework is shaped to rest on the side plates of the cradle to support the tray in the correct alignment for loading.

The bearers are of tubular steel and are provided with marline grips and steel collars, to ensure a good hold for the hands.

The *Mark II* tray differs from the *Mark I*, described above, principally as follows:—The top edges of the projectile plate are beaded; the nose tray bracket has ribs formed at each side to which the front end of the stays are attached; the front and rear brackets are in one piece instead of being built up.

Wrenches, Breech Mechanism.—The following wrenches are used with the breech mechanism:—

No. 137.—For nut, vent axial and pin, actuating plate retaining breech screw.

No. 138.—For screws fixing control arc and rotating cam, screw fixing B.M. lever bearing, screw fixing B.M. lever catch plate and nut for crank shaft.

No. 173.—For nut, vent bush spindle.

No. 199.—For use when assembling and dismantling "V" slide box and P.H. percussion lock.

PART VII.

AMMUNITION.

Nature.	Mark (a).	Projectiles.		Bursting Charge.		Average Weight filled and fuzed.		Nature of Fuzes.	Cartridges.			Means of Firing.
		Nature.	Weight.	Nature.	Weight.	lb.	oz.		Nature.	Size.	Weight.	
Shell, B.L., H.E., 6-inch Howitzer, light.	XVI	H.E.	11 5 7	11 5 7	100	0	Percussion, with cap No. 106 or 106E.	—	—	—	—	
Shell, B.L., H.E., Stream line, 6-inch Howitzer, 86-lb.	Id	"	9 13 7	9 13 7	86	0	Percussion, No. 101 or 101E and gaine No. 2.	—	—	—	—	
Shell, B.L. or Q.F., Common pointed, 6-inch.	XIII	Shellite 67/40	5 3 6	5 3 6	100	0	Time, No. 188A, with No. 12 adapter and gaine No. 2 (b).	—	—	—	—	
Shell, B.L., Chemical, 6-inch Howitzer, light.	VIII	—	0 6 14	0 6 14	100	0	Percussion, with cap No. 105 or 106E.	—	—	—	—	
Shell, B.L. or Q.F., Incendiary, 6-inch.	II	Powder	0 0 12	0 0 12	100	0	Percussion, base, large, bronze, No. 16.	—	—	—	—	
Shell, B.L., Smoke, 6-inch.	I	"	0 9 0	0 9 0	103	0	Percussion, with cap No. 106 or 106E.	—	—	—	—	
Shell, B.L. or Q.F., Star, 6-inch.	VI	"	0 0 7	0 0 7	90	0	Time and Percussion, No. 82.	—	—	—	—	
Shell, B.L., Star or star signal, 6-inch.	VIII	"	0 0 7	0 0 7	100	0	Percussion, No. 101 or 101E and gaine No. 2.	—	—	—	—	
		"	0 0 7	0 0 7	100	0	Time, No. 183	—	—	—	—	
		"	0 0 7	0 0 7	100	0	Time, No. 183	—	—	—	—	

(a) Other marks may be met with.

(b) For air ranging.

SHELL, B.L., H.E., 6-INCH HOWITZER, LIGHT, MARK XVI.
(Plate XXXIII.)

The *Mark XVI* shell consists of a forged steel body having parallel walls which taper off slightly towards the base. The head which is made removable and struck with a radius of 2 calibres, is forged separately, the nose being screwed to the 2-inch fuze hole gauge and prepared to take an exploder container.

A steel plate disc is screwed or riveted into the base and a copper driving band is fitted into an undercut groove near the base, the groove having three waved ribs or knurling to prevent the band turning on the shell.

SHELL, B.L., H.E., STREAM LINE, 6-INCH HOWITZER, 86-LB.,
MARK ID.
(Plate XXXIV.)

This shell is of forged steel with tapered walls and a 9.25-calibre radius head, which is prepared to take a container, the latter being threaded internally to the 2-inch fuze hole gauge. The base, which is fitted with a steel base plate screwed or riveted in, is tapered off externally below the driving band at an angle of 8 degrees. The driving band is similar to that described above.

SHELL, B.L. OR Q.F., COMMON POINTED, 6-INCH, MARK XIIIa.
(Plate XXXV.)

The *Mark XIIIa* shell is of cast or forged steel with a 4-calibre radius head. The walls of the shell are parallel, tapering off at the shoulder.

The cavity is threaded at the base to take a base adapter which is threaded internally to receive the fuze and externally to take a base cover plate consisting of a screwed ring and perforated plate. Six holes are bored through the perforated plate to allow the gas to act on the pressure plate of the fuze.

A copper gascheck driving band is fitted into an undercut groove near the base; the groove has four waved ribs to prevent the band turning on the shell.

SHELL, B.L., CHEMICAL, 6-INCH HOWITZER, LIGHT, MARK VIII.
(Plate XXXVI.)

This shell is of iron or semi-steel with a 2-calibre radius head and tapering walls; the base is solid. The head is prepared to take a container for the bursting charge; the container is threaded internally to the 2-inch fuze-hole gauge.

A tapered charging hole is drilled in the body of the shell below the shoulder; the hole is closed after charging by driving in a steel charging hole plug.

The driving band is similar to that described for H.E. shell.

SHELL, B.L. OR Q.F., INCENDIARY, 6-INCH, MARK II.

(Plate XXXVII.)

The *Mark II* shell is of forged steel with parallel walls and a 2-calibre radius head.

The head is formed separate from the body and is secured to it by fixing screws and twisting pins. The base, which is solid, is fitted with a base plate screwed or riveted in and provided with a driving band similar to that described for Common Pointed Shell on page 62.

SHELL, B.L., SMOKE, 6-INCH, MARK I.

This shell is of forged steel with a 2 calibre radius head and parallel walls tapering slightly at the base and shoulder. A steel plate is screwed or riveted into the base.

The head is prepared to take a steel exploder container, the container being threaded to the 2-inch fuze hole gauge. A tapered charging hole is drilled in the body of the shell below the shoulder, the hole is closed after charging by driving in a steel charging hole plug.

The base is fitted with a copper gascheck driving band similar to that described for Common Pointed Shell on page 62.

SHELL, B.L. OR Q.F., STAR, 6-INCH, MARK VI.

(Plate XXXVIII.)

The *Mark VI* shell is of the parachute type. It is of forged steel with a 2-calibre radius head and parallel walls. The base, which is separate, is secured in position by three copper shearing pins and prevented from revolving in the shell by a steel pin.

The driving band is similar to that described for Common Pointed Shell on page 62.

SHELL, B.L., STAR OR STAR SIGNAL, 6-INCH, MARK VIII.

The *Mark VIII* shell is generally similar to the *Mark VI* star shell described above, differing chiefly in the base being secured in position by six shearing pins and prevented from revolving by three steel pins.

FUZES.

INSTRUCTIONS RELATING TO THE CARE OF NOS. 106 AND 106E
FUZES.

(1) The (safety) cap of the Nos. 106 and 106E fuzes must be removed and the wire seal broken *only* immediately prior to firing.

(2) If a No. 106 or 106E fuze has become uncapped in any manner except that referred to in (1), or has had the wire seal inadvertently broken, it is to be regarded as unfit for firing and is to be withdrawn from use.

(3) Fuzes withdrawn under paragraph (2) are to be examined to ascertain if the brass tape under the hammer head is present and correct; if this is so, the (safety) cap should be replaced and secured in position by a becket, and the fuze returned to the Ordnance Store for transmission to Woolwich. If examination shows that the brass tape is incorrect, or missing, the fuze may be in a *dangerous condition* and must be destroyed under expert supervision.

In securing the (safety) cap with the becket, difficulty may arise with fuzes, where the body is not provided with an eye through which the becket may be threaded; in such cases, wooden pegs should be driven in the fixing key holes in the body and the becket fastened round these.

(4) It is essential that the becket should be fastened in such a manner so as to prevent the cap coming off in transit to Woolwich. The method of fastening the fuze cap is as shown on Plate XXXIX.

FUZE, PERCUSSION, BASE, LARGE, BRONZE, NO. 16, MARK IV.

(Plate XL.)

The *Mark IV* fuze consists of the following parts:—Body, detonator pellet, pressure plate, screwed cap, protecting ring, centrifugal bolt, three springs, pea ball, small retaining bolt, locking pellet, steel needle, detonator plug, set screw for cap, retaining bolt for pea ball, screwed pin and four closing plugs.

The *body*, which is of aluminium bronze, is turned and screwed on the exterior to suit the shell; the interior is bored out and screwed, the bottom of the bore being coned and recessed for the detonator pellet. A hole is bored through the side of the body to receive the small end of the centrifugal bolt and closed by a screwed plug; a hole is also bored through the opposite side of the body to receive the small retaining bolt and is closed by a screwed plug. A third hole is bored and screwed at an angle of 45 degrees to the first hole to receive the screwed pin for the detonator pellet. Further holes are bored, one to receive the retaining bolt for pea ball and two others longitudinally one for the channel which contains five powder pellets and the other for the pressure plate: a hole is also bored from the powder pellet channel to the centre of the body. The top of the body has a circular recess for a compressed powder ring and two elongated holes are cut in the base for screwing in the fuze.

The interior of the *detonator pellet* is bored out and screwed at the top to receive the detonator plug and detonator and a flash hole is bored through. A hole is bored at right angles to the axis for the centrifugal bolt and further holes for the brass pin of the centrifugal bolt, locking pellet and small retaining bolt. The exterior of the pellet at the top is recessed to form a seating for the spring, and the bottom is reduced in diameter, forming a cone with flange and stem to suit the interior of the body. A slot in the pellet engaging with a pin screwed into the body prevents the pellet turning in flight.

The *detonator* contains about 3 grains of composition.

The *pressure plate* is of copper, it is cupped and has a lip round the edge to form a gascheck. Near the top the spindle of the plate

is reduced in diameter to enter the slot in the small retaining bolt, when in flight.

The *steel protecting ring* is screwed into the recess in the base below the pressure plate and secured by punch stabs.

The *screwed cap* has a curved top and the lower part is reduced in diameter and bored out to accommodate the spring and threaded to suit the body. The centre of the cap is threaded to take a steel screwed needle and six fire holes are bored through the flange; the cap is secured by a set screw.

The *centrifugal bolt* is fitted with a brass pin which engages in a hole in the detonator pellet to prevent the bolt turning; a flash hole is bored through the stem of the bolt.

The *small retaining bolt* prevents any movement of the centrifugal bolt except when in flight.

The *pea ball* seals the channel in the body containing the powder pellets and is held in position by its retaining bolt with spring.

The *locking pellet*, on impact, locks the detonator pellet in the forward position, it being forced into the recess for the centrifugal bolt in the body through the action of its spring.

The fuze requires no preparation before loading.

Action.—On discharge, the gas pressure crushes in the pressure plate, carrying forward the spindle, thus bringing the reduced diameter of the spindle opposite the small retaining bolt. The rotation of the shell causes the bolts to move outwards; the slot in the small retaining bolt fitting round the reduced part of the spindle allows the centrifugal bolt to withdraw its projecting end from the recess in the body and to bring its vertical flash hole in line with the fire channel in the pellet. At the same time, the retaining bolt in the base of the fuze, acted upon by centrifugal force, moves outwards, compressing its spiral spring, thus allowing the pea ball to move out of its seating and open the fire channel in the base.

On graze or impact, the detonator pellet moves forward, overcoming the spring and carrying its detonator on to the needle at the same time withdrawing the flange round its base from the groove in the bottom of the percussion chamber.

The locking bolt, engaging with the recess in the body, retains the pellet in the forward position and thus allows the flash from the detonator to pass down through the channel in the centrifugal bolt and pellet, through the hole left open by the pea ball, to the powder pellets in the vertical channel, thus firing the magazine in the front end of the fuze, the flash from which, passing through the six fire holes in the cap, explodes the bursting charge of the shell.

Packed one in a tin cylinder, No. 11 F. Weight, 2-lbs. 8½-ozs.

FUZE, PERCUSSION, No. 101E, MARK II.

(Plates *XLI* and *XLII*.)

The fuze consists of the following principal parts:—

Body, cap with needle, graze pellet, plug, detonator, creep spring, centrifugal bolt, detent, detent spring, safety shutter and adapter.

(B 14096)

E

The *body* is screw-threaded externally at its lower end to the 2-inch fuze-hole gauge, while its upper end is conical in shape and fitted with a rounded cap which is screwed into the upper end. Below the cap the body is bored out to receive the graze pellet and below this again a fire channel leads to the safety shutter. A second opening, of two diameters, is bored in the body parallel to the fire channel for the reception of the detent and its spring; after assembly and inspection of the empty fuze this opening is closed at the top by a brass or copper ball. Near the upper end of the opening of the larger diameter and through that of the smaller diameter a hole is bored at right angles for the centrifugal bolt. Around the outside of the body is a knurled ring, black band or groove to denote that the fuze is not fitted with a cocked pellet (as in the case of the No. 100 fuze) and slots are provided to receive the "Key, No. 53" for fixing purposes. A groove is formed round the lower end of the body for the purpose of punch stabbing the fuze into the shell.

The lower end of the body is bored out and screwed to receive an adapter.

The *cap*, which is screwed into the upper end of the body, has a steel needle screwed in from the top.

The *graze pellet* is hollow and is screwed internally at its lower end for the plug. Its upper end is stepped to form seatings for the centrifugal bolt and creep spring. The space between the bottom of the pellet and the top of the shutter is filled by a paper cylinder.

The *plug*, which is screwed into the graze pellet from the underside, has a central fire channel through it. It forms a support for the detonator.

The *detonator* consists of a copper cup containing 1.7 grains of detonating composition; the top of the composition is covered by a brass disc and copper washer and its underside by a brass disc, the whole being held in the cup by the top edge of the latter being spun over. It fits inside the graze pellet, in which it is held by the plug.

The *creep spring* is interposed between the upper end of the graze pellet and the underside of the cap.

The *centrifugal bolt* is fitted in an opening at the upper end of the body, the opening being closed by a screw plug. The bolt is kept in position by the stem of the detent, which passes up behind it. Its inner end fits over a shoulder on the upper end of the graze pellet.

The *detent* consists of a body with pin connected by a ball and socket joint; the stem of the latter passes up through a hole in the top of the fuze and behind the centrifugal bolt and is kept in position by a spiral spring which bears against the underside of the body and is held in position by a plug screwed into the body of the fuze.

The *safety shutter* consists of a metal shutter which is slotted at one end to take the stem of a detent and a spiral spring, the whole being supported on a metal disc having a central fire hole. The detent shutter and spring are carried in a groove in the top of the adapter and are screwed in position by a tinned plate cap having a central fire hole. The cap forms a bearing for the head of the detent and shutter spring.

The *adapter* is screwed externally at its upper end to screw into the bottom of the fuze, in which it is held by a set screw and internally for the greater part of its length to receive the gauge,

which in turn, is held by a set screw. The upper end of the central opening is plain and enlarged to form a chamber for the reception of the safety shutter.

Action.—On firing, the detent behind the centrifugal bolt sets back, compressing its spring. When the stem of the pin is clear of the fuze body, centrifugal force carries the stem over and the spring re-asserting itself, jams it under the shoulder of the recess. This leaves the centrifugal bolt free and the rotation of the shell causes the bolt to move outwards and so unlocks the graze pellet. While the shell is under acceleration in the bore the comparatively slow rate of rotation and the friction caused by the set back of the shutter prevents the latter opening. After the shell has left the bore the shutter is moved outwards by centrifugal force, compressing the spring. In moving outwards it releases the detent, the stem of which drops down and engages a shoulder in the shutter and thus keeps the shutter clear of the fire-holes in cap and disc. During flight the graze pellet is prevented from moving forward by the creep spring, but on graze or impact it moves forward, carrying the detonator on to the needle. The flash from the detonator passes down through the fire channels to the gaine, which in turn detonates the bursting charge in the shell.

Packed one in a tin cylinder, No. 101 F.

FUZE, PERCUSSION, NO. 101.

This fuze is generally similar to the No. 101E described above from which it differs principally in not being provided with a safety shutter.

FUZE, PERCUSSION, WITH CAP, NO. 106E, MARK IV.

(Plate XLV.)

The *Mark IV* fuze consists of the following principal parts: body, cap, hammer, steel collar in halves, brass tape with weight, steel and dermatime washers, copper shearing wire, steel guide pin, detonator holder, detonator, magazine with shutter, shutter spring, bottom screwed cap, shalloon and paper discs.

The *body*, which is made of bronze, is screw-threaded externally at its lower end to suit the 2-inch fuze-hole gauge. Its upper end, which is generally conical in shape, terminates in a cylindrical stem, which is screw-threaded to receive the cap. Slots are cut in the body to receive the No. 53 key for fixing purposes. The body is further prepared to receive a shearing wire, guide pin and a counter-sunk hole to take the wire securing the cap. A groove is cut round the shoulder for punch stabbing the fuze into the shell when fuzing the latter.

Internally the body is bored out in different diameters to receive the hammer, detonator holder, and magazine.

The *hammer* is of steel, fitted with an aluminium head. The lower end is pointed to form a needle. Just below the head a recess is bored to take a stud on one-half of the steel collar and in one side a slot is cut through which fits the shearing wire and guide pin. The hammer is placed in position from the top of the fuze body passing through a steel washer on the top of the latter. The guide

pin is screwed into the body, one end entering the slot in the hammer. The shearing wire passes through the body and hammer, the ends being afterwards turned over. The function of the guide pin is to prevent the hammer turning whilst the tape is being wound or unwound, while the shearing wire keeps the hammer clear of the detonator after the collar has become detached, until the shell strikes. Around the hammer, under the head and resting on the steel washer of the body, is a steel collar in halves, one-half of which has a pin to fit the recess in the hammer, and around this again is wound a brass tape to one end of which is soldered a weight. The top of the fuze is then closed by a \cap -shaped steel or malleable cast iron cap which screws on to the projection at the top of the body against a dermatine washer, and is held in position by a steel wire which passes through an eye in the cap, the two ends being twisted, a complete turn is then taken round the cap and the loose ends inserted in the hole provided in the body and fixed therein by a lead plug pressed in.

The *steel collar* and tape prevent the hammer moving on to the detonator until they have been freed by the rotation of the shell during flight, and so prevent any possibility of a premature in the bore or near the muzzle.

The *detonator holder* is held in position by the top surface of the magazine. Its upper end is recessed to receive the detonator, which is held in position by the mouth of the holder being spun over. A cupro-nickel or brass disc is placed on top of the detonator. An opening is bored through the centre of the holder which is filled with loose "composition, exploding" the opening being closed by a paper disc shellaced to the bottom of the holder.

The *magazine* is screwed externally to suit the interior of the body and is reduced in diameter near the bottom and screwed to receive the bottom cap. The top of the magazine is recessed and fitted with a shutter and spring which swings open when the fuze is spun during flight. The bottom of the magazine is bored out to contain a compressed C.E. pellet and is closed by the bottom cap.

A *set screw* is screwed into a hole in the body of the fuze and holds the magazine in position.

Preparation of Fuze.—To prepare the fuze the wire is broken, and the cap unscrewed and removed at the moment of loading.

Action.—On de-acceleration after leaving the bore the rotation of the shell causes the weight on the tape to fly outwards, causing the latter to become unwound from the steel collar, the latter in turn drops off, leaving the hammer supported only by the shearing wire.

The rotation of the shell during flight causes the shutter to swing outwards until a hole formed in it comes into line with the central perforation in the detonator holder and on impact the hammer is driven in, breaking the shearing wire and piercing the detonator. The flash from the detonator ignites the loose "composition, exploding" in the detonator holder, which in turn detonates the magazine, and from thence the flash passes to the bursting charge in the shell.

The *Mark IVs* fuze differs from the *Mark IV*, in the head of the hammer being made of steel, instead of aluminium.

Packed one in a tin cylinder No. 101 F with exploder.

FUZE, PERCUSSION, WITH CAP, No. 106L

(Plate XLIII.)

This fuze is generally similar to the No. 106E fuze described above from which it differs principally in not having a removable magazine with safety shutter.

FUZE, TIME AND PERCUSSION, No. 82, MARK. V.

(Plate XLV.)

The fuze consists of the following principal parts:—Body, cap, percussion pellet with detonator, creep spring, three retaining bolts with spiral springs for percussion pellet, brass cap and base plug, lower time ring, upper time ring with needle plug, time detonator pellet with detonator, three retaining bolts with spiral springs, safety pellet with shearing wire, screwed needle, two safety pins and set screw.

The *body* is made of aluminium, the lower part screw-threaded on the exterior to the 2-inch gauge. Above the screwed portion the body is of larger diameter, forming a flange to support the time rings. A cloth washer is shellaced to the top of the flange, while its outer edge is graduated from 0 to 40, each graduation being divided into five parts, a red + indicating the safety point. A slot is also provided to take the "Key, No. 19" for fixing or removing the fuze. Near the "0" graduation a small vertical hole is bored in the body into which is placed a perforated powder pellet which communicates with the magazine by means of a small channel filled with powder. The hole and the channel are fitted with brass linings. The body is bored out from the bottom to form a percussion chamber, into the top of which is screwed a *steel needle*.

The stem of the body, which is screwed at the top to take the cap, has four brass-lined holes, at right angles to the axis of the fuze, for the time detonator pellet and three retaining bolts with springs. A hole is bored, parallel with the axis of the fuze, for the safety pellet.

The *cap* which is of aluminium or brass, is screwed to the top of the body and secured by a set screw.

The *percussion pellet* is made of metal, cylindrical in shape; the front end is reduced in diameter forming a shoulder to support the *creep spring* which prevents the pellet moving forward during flight. A hole bored vertically through the pellet contains at its upper end a *detonator*, below which is a perforated powder pellet retained in position by a disc of paper and a brass washer spun in.

The *retaining bolts* pass through the side of the body; each bolt is pressed inwards, by means of a small spiral spring, into a hole in the side of the percussion pellet and so locks the latter until the bolts are spun out by the rotary motion of the shell.

The *brass cap*, which has a central hole covered with a shalloon disc, is secured into and closes, the percussion chamber.

The *base plug* is made of metal and screws into the base of the fuze. The upper surface of the plug is hollowed out to form

a magazine which is filled with F.G. powder; a hole in the centre of the plug is closed by a muslin disc and brass washer spun in.

The *lower time ring* rests on the cloth washer on top of the flange of the body; it fits around the stem and is free to turn, having a slot to take the "Key, No. 36," for setting purposes.

On the underside of the ring a channel is cut which is filled with composition. A small hole through the ring at the commencement of the composition contains a perforated powder pellet to communicate with the top ring; at the same place there is also a gas escape hole bored through to the exterior, the hole being closed by a brass disc. The beginning of the composition is indicated by a setting mark. The upper surface of the ring is covered with a cloth washer and the underside with a washer of vegetable paper.

The *upper time ring* has four recesses, to correspond with holes for the time detonator pellet and retaining bolts in the stem. It has a composition channel and gas escape hole similar to the lower ring. The ring is fitted with a needle plug, underneath which is a perforated powder pellet communicating with the beginning of the fuze composition. The ring is pinned to the stem to prevent it turning.

The *time detonator pellet* contains a detonator consisting of 0.75 grain of detonating composition and a 0.87-grain powder pellet.

The pellet is prevented from moving outwards against the needle by two *retaining bolts*, which are in turn locked by a third one, the latter in its turn being locked by the safety pellet.

The *safety pellet* is of brass, cylindrical in shape, with a deep groove formed round its circumference; it is suspended by means of a copper shearing wire and the safety pin, in a vertical hole at the top of the stem. Its lower end engages with a radial groove formed in the retaining bolt and so prevents the latter moving until the pellet has been set back by the shock of discharge.

The *percussion safety pin* passes through the body of the fuze and the percussion chamber and so prevents any forward movement of the percussion pellet until the pin is withdrawn. A small metal closing pellet with spring, fitting into a vertical recess, closes the safety pin-hole when the latter is withdrawn.

The *time safety pin* passes through the body of the fuze and the safety pellet.

The fuze is stamped T on the top composition ring close to the time safety pin and P on the body close to the percussion safety pin. The pins are each provided with a whipcord becket or loop, the T one being scarlet and the P one tarred.

The mean time of burning set full and corrected for barometer is 40 seconds \pm .25 seconds.

Weight, 1-lb. 2-oz. 10-drs.

To set the time arrangement, the bottom ring is moved round with the Key, No. 36, until the graduation ordered and the setting mark coincide.

If the fuze is required to act as a percussion fuze only, the P pin only should be removed; otherwise, both pins should be removed. This, however, should not be done until the moment of loading.

The fuzes are packed one in a tin cylinder 25 cylinders in a wooden case.

Action of Fuze—Time Arrangement.—On shock of discharge, the safety pellet sets back shearing the suspending wire and releases one of the retaining bolts. The rotary motion of the shell now causes the retaining bolts and the time detonator pellet to fly outward and the latter, coming into contact with the needle plug, fires the detonator.

The flash passes to the composition in the underside of the top ring and burns until it reaches the hole in the bottom ring, the composition of which burns back in the opposite direction until it reaches the hole in the body, where it flashes down to the magazine base plug and thence into the shell.

Percussion Arrangement.—The rotary motion of the shell causes the retaining bolts of the percussion pellet to fly outward, leaving the percussion pellet free to move forward on impact or graze on to the needle, firing the detonator, the flash then passing to the magazine in the base plug and thence into the shell.

FUZE TIME. NO. 183.

(Plate XLVI.)

The *Mark V* fuze, which is converted from the T and P, No. 83, Mark V, consists of the following principal parts which are made of gunmetal, except where otherwise stated:—Body, time pellet with detonator, screwed needle, brass pins and washers, base plug, screwed plug, top and bottom composition rings and cap.

The *body* is screwed at the lower end to the 2-inch fuze-hole gauge and bored from the bottom to receive the percussion arrangement. On conversion to No. 183 fuze the percussion arrangement is omitted and the space filled by a wood plug driven in. It is further bored to form a magazine which is filled with fine grain powder, and closed with a base plug; an oblique hole leading upwards from this magazine to connect with the bottom composition ring is filled with fine grain powder. A vertical recess is drilled centrally in the stem of the body to take the time arrangement, with a fire channel leading to the top time ring. A double pointed needle is screwed into the diaphragm separating the recess for the time arrangement from the opening in the base to take the percussion arrangement. The stem of the body is fitted with two slots for pins, to prevent the top composition ring from turning and is screwed to take the cap. The cap which may, as an alternative, be made of mild steel, rustproofed, is threaded internally to fit the stem of the body; a slot is cut across the top to take the "Key, No. 48" or a screwdriver for clamping purposes when setting.

The flange of the body is engraved with graduations from 0 to 22 (in tenths) and with an arrow in red to denote the position of "safety." When the arrow and the line on the bottom ring coincide the fuze is set at "safety."

A slot in the flange of the body takes the "Key, No. 17 or Key, No. 32" for fixing purposes.

The top and bottom composition rings have a channel on their underside filled with composition and a hole is provided in each

which allows the gas direct escape outside; this escape hole is lightly closed by means of a brass disc covered without by Pettman's cement and waterproofed. Two semi-circular slots are cut on the inside of the top ring which, in conjunction with the two slots in the stem and two pins, prevent the ring from turning.

A hole is bored in the top ring to convey the flash of the time detonator to the composition. A similar hole is bored in the bottom ring to convey the flash from the top ring. A cloth and vegetable paper washer is placed between the rings and between the bottom ring and the body. The bottom ring is fitted with a setting pin to take the "Key, No. 18" and is engraved with a line for setting purposes.

The time pellet contains a .75 grain detonator and powder pellet and is supported above the time needle by means of a spiral spring.

The base plug is screwed externally to fit the bottom of the body. A hole is bored through the centre and a recess is formed to take a brass and linen disc, the metal of the plug being burred over to hold them in position,

The screwed plug is screwed externally to suit the recess in the body and serves to retain in position the wood plug.

The openings in the fuze are filled with waterproof composition.

To set the fuze.—Unclamp the cap and with "Key, No. 18," or by hand, revolve the bottom ring until the line coincides with the required graduation on the body. Then clamp the cap and check the setting.

Action.—On discharge, the time pellet sets back on the time needle, overcoming the resistance of the spiral spring and firing the detonator. The flash passes through the fire channel in the stem to the composition in the top time ring which burns until the channel communicating with the bottom time ring is reached, the composition of which burns in the opposite direction until it reaches the channel leading to the magazine in the fuze, whence the flash passes through the base plug into the shell.

These fuzes are distinguished by having a 1-inch "T" stencilled on the fuze in blue.

Mean time of burning set full, after correcting for
 barometer 30 seconds.

Packed one in a tin cylinder, No. 87F, Mark II.

FUZE, TIME, NO. 188M, MARK V.

This fuze is similar to the No. 183 Mark V, described above, except that the bottom time ring is filled with special composition and the mean time of burning of the fuze is 48 seconds; a perforated powder pellet is inserted in the magazine in place of a charge of powder, the powder pellet being retained in position by a paper disc placed over the pellet and secured to the base plug with shellac. The exterior of the bottom time ring is lacquered red to indicate the special filling.

ADAPTER, 2-INCH FUZE HOLE, No. 12.

This adapter is made of steel or metal and is for use with time fuzes and No. 2 gaine in H.E. shell.

It is screwed on the exterior to the 2-inch fuze-hole gauge for a certain distance below which it is turned plain. A hole is bored out from the bottom and screwed to receive a No. 2 gaine and a groove is cut across the top to accommodate a shutter which is retained in position by a perforated tinned plate cap soldered to the top of the adapter.

GAINE, No. 2.

The gaine, which acts as an exploder to H.E. shell, is made of steel and consists of a hollow cylinder containing explosive. The cylinder is screwed externally at one end to suit the screwed recess of the adapter with which it is used. The screwed end of the cylinder is closed with a shellaced disc and the opposite end with a screwed plug or cap.

CARTRIDGE, B.L. 6-INCH 26-CWT. HOWITZER.

4-LB. 11½-OZ. CORDITE M.D. OR R.D.B. SIZE 8, MARK II.

(Plate XLVII.)

This cartridge consists of a core and two sections of cordite M.D. or R.D.B. size 8, each part being contained in a separate shalloon or cream serge bag.

The core consists of 2-lb. 12½-oz. of cordite bundled together and tied in four places with silk sewing. The centre sticks are about 10½ inches long forming a stalk and the outer ones 3½ inches long forming a base, to the bottom of which is stitched an igniter and on top it forms a shoulder on which the sections rest. The two sections, which consist of 11¾-oz. and 1-lb. 3¼-oz. cordite respectively, are made up of sticks about 7 inches long. They are semi-circular in shape to fit around the stalk of the core, and are stitched to the latter in four places, two at the top and two at the bottom.

The igniter consists of two discs of shalloon stitched across to form four parallel compartments which contain a minimum of 1-oz. of R.F.G.² or S.M.¹ powder.

Packed 25 in "box, cartridge," or 20 in "case, powder, M.L., whole," C. 118, the latter being special for India.

TUBES.

TUBE, PERCUSSION, S.A. CARTRIDGE, MARK I.

(Plate XLVIII.)

This tube is used with Martini-Metford or lock, percussion, P.H. firing mechanisms. The form and general dimensions are shown on Plate. It consists of a body with cap and cork disc.

The body and cap consist of the .303 rifle cartridge case filled with a charge of 30 grains, S.M.¹ powder. It is closed at its front end with a cork disc which is covered with shellac varnish before insertion and the exposed side afterwards waterproofed with shellac.

Packed 20 in a Box, Tube, Percussion, S.A. Cartridge.

NOTES.

In the event of a tube failing to ignite a charge, care should be taken in extracting the fired tube not to stand directly in rear of the howitzer, as the gas generated will cause the tube to fly out with some violence so soon as the lock is open.

The vent channel sometimes becomes choked with residue from the cartridge. When this occurs the taper portion should be cleared with a rimer, sufficiently to allow of the insertion of a tube, which, when fired, will remove the rest of the obstruction.

(As to prices in brackets, see top of page 2.)

HISTORIES, SHORT, OF THE TERRITORIAL REGIMENTS OF THE BRITISH ARMY. 67 numbers, each 1d. (1d.); In one volume, 5s. (3s. 9d.)

- | | |
|--|---|
| Ditto. The Scots Guards. 1d. (1d.) | |
| Ditto. The 6th (Inniskilling) Dragoons. 1d. (1d.) | |
| Ditto. Revised Editions. Each 1d. (1d.):— | |
| Alexandra, Princess of Wales's Own (Yorkshire Regiment). | The Northamptonshire Regiment. |
| The Bedfordshire Regiment. | The Oxfordshire and Buckinghamshire Light Infantry. |
| The Black Watch (Royal Highlanders). | The Prince of Wales's Leinster Regiment (Royal Canadians). |
| The Cameronians (Scottish Rifles). | The Prince of Wales's Own (West Yorkshire Regiment). |
| The Cheshire Regiment. | The Prince of Wales's Volunteers (South Lancashire Regiment). |
| The Duke of Cornwall's Light Infantry. | The Princess Charlotte of Wales's (The Royal Berkshire Regiment). |
| The Duke of Wellington's West Riding Regiment. | The Princess Louise's Argyll and Sutherland Highlanders. |
| The Durham Light Infantry. | The Queen's (Royal West Surrey Regiment). |
| The East Lancashire Regiment. | The Royal Inniskilling Fusiliers. |
| The East Surrey Regiment. | The Royal Sussex Regiment. |
| The Hampshire Regiment. | The Royal Welsh Fusiliers. |
| The Highland Light Infantry. | The South Staffordshire Regiment. |
| The King's Own (Royal Lancaster Regiment). | The Suffolk Regiment. |
| The King's Own Scottish Borderers. | The Welsh Regiment. |
| The Lancashire Fusiliers. | The Worcestershire Regiment. |
| The Leicestershire Regiment. | |
| The Loyal North Lancashire Regiment. | |

HORSES. ARMY. Notes on the Feeding, Management, and Issue of. 1d. (1d.)
See also ANIMAL MANAGEMENT.

HOSPITALS. MILITARY FAMILIES'. Nursing Staff Regulations. Dec. 1909. 1d. (1d.) See also NURSING SERVICE and TERRITORIAL FORCE.

HOSTILITIES WITHOUT DECLARATION OF WAR FROM 1700 TO 1870. 2s. (1s. 7d.).

HYGIENE. ELEMENTARY MILITARY. Manual of. 1912. 6d. (6d.)
See also PHYSIOLOGY AND SCHOOLS.

INDIAN EMPIRE. THE. A short review and some Hints for the use of Soldiers proceeding to India. 6d. (6d.)

INFANTRY TRAINING. (4-company organization.) 1914. (Reprinted 1916). 6d. (6d.)

Ditto. Amendments, July, Aug. 1916; Dec. 1918. Each 1d. (1d.)

INJURIES AND DISEASES OF WAR. Manual based on experience of the present Campaign in France. Jan. 1918. 9d. (8d.)

INSTITUTES. Garrison and Regimental. Rules for the Management of. 1916. 1d. (1d.)

ITALIAN CAVALRY TRAINING REGULATIONS. 1911. Training for Marches, Tactics of Minor Units, and Training of Patrols. Translated. 4d. (3d.)

JAMAICA. Standing Orders. 1912. 1s. (9d.)

JERSEY. ROYAL MILITIA OF THE ISLAND OF. Regulations. 1914. With the Jersey Militia Law, 1905. 1s. 8d. (11s.)

KING'S REGULATIONS AND ORDERS FOR THE ARMY. 1912. (Reprinted, with Amendments published in Army Orders up to Aug. 1, 1914). (Reprinted 1918.) 1s. 6d. (1s. 2d.); Amendments published in Army Orders between Sept. 1, 1914, and Aug. 1, 1916. 1d. (1d.); Amendments published in Army Orders between Sept. 1, 1916 and March 1, 1918. 1d. (1d.)

KIT PLATES:—

Artillery. Royal—

6. Garrison. Kit laid out for Inspection. 1909. 2d. (2d.)

10. Ditto. Kit in Barrack Room. 1909. 2d. (2d.)

Cavalry. 1891. 1d. (1d.)

Engineers. Royal—

1. Dismounted. Detail of Shelf and Bedding, with Marching Order ready to put on. Detail of Shelf and Bedding, with Drill Order ready to put on. 1914. 1d. (1d.)

2. Dismounted. Full Kit laid out for Inspection in Barrack Room. 1914. 1d. (1d.)

4. Mounted N.C.O. or Driver and Field Troop Sapper. Full Kit laid out for Inspection in Barrack Room. 1910. 1d. (1d.)

5. Mounted. Detail of Shelf and Bedding. 1910. 1d. (1d.)

6. Driver, with pair of Horses. Field Kit laid out for Inspection on Parade, including Articles carried in Valise on Baggage Wagon. 1899. 1d. (1d.)

Infantry—

Highland. 1884. 1d. (1d.)

Medical Corps. Royal Army. Kit in Barrack Room. 1912. 2d. (2d.)

Ordnance Corps. Army. For Guidance at Marching Order and Kit Inspections. 2d. (2d.)

MILITARY BOOKS, published by Authority—continued.

(As to prices in brackets, see top of page 2.)

- LARGE FORMATIONS.** The Operations of. (Conduite des Grandes Unités) Translated from the Field Service Regulations of the French Army, dated Oct. 28 1913. 6*d.* (5*d.*)
- LAW.** Military. Manual of. 1914. (Reprinted 1917). 3*s.* 6*d.* (2*s.* 10*d.*) Amendments. May 1919. 1*d.* (1*d.*)
- MACHINE-GUN COMPANY TRAINING.** Infantry. 1917. Provisional. To be read in conjunction with Infantry Training and Musketry Regulations. 6*d.* (5*d.*)
- MACHINE GUNS AND SMALL ARMS, .303-inch.** Nomenclature of Parts, Stripping, Assembling, Action, Jams, Missfires, Failures, and Inspection of Revised Edition. 1917. 6*d.* (6*d.*)
- MAGAZINES AND CARE OF WAR MATERIEL.** Regulations for. 1913. (Reprinted, with Amendments, published in Army Orders up to March 31, 1917.) 1*s.* 6*d.* (1*s.* 3*d.*)
- MALARIA.** Observations on, by Medical Officers of the Army and others. (With Plates and Diagrams.) 1920. 6*s.* (4*s.* 5*d.*)
- MAP READING AND FIELD SKETCHING.** Manual. 1912. (Reprinted, with Additions, 1914). 1*s.* (11*d.*) See also PROTRACTOR.
- MEDICAL CORPS.** Royal Army. See also TERRITORIAL FORCE.
Admission to. Regulations for. Jan. 1912. 1*d.* (1*d.*)
Standing Orders. 1914. 1*s.* (10*d.*)
Training. 1911. 9*d.* (9*d.*) See also TERRITORIAL FORCE.
- MEDICAL DEPARTMENT.** Army. Index to Appendices of Reports from 1859 to 1896. 8*d.* (8*d.*)
- MEDICAL DISEASES** in the Tropical and Sub-Tropical War Areas. See DISEASES.
- MEDICAL SERVICE.** Army:—
Regulations. 1906. (Reprinted, with Amendments up to Sept. 30, 1914). 4*d.* (5*d.*)
Ditto. Amendment, Dec. 1916. Revised Appendix No. 51. Scale of Medical and Surgical Equipment for Units in the Field. 1*d.* (1*d.*)
- MEDICAL SERVICE.** Strategical and Tactical Employment of the, as carried out in an Army Corps; with a series of Problems. Translated from the Austrian. 4*s.* 6*d.* (8*s.* 4*d.*)
- MEDICAL SERVICES.** Army. Advisory Board for. The Treatment of Venereal Disease and Scabies. First Report. 1904. 1*s.* 6*d.* (1*s.* 3*d.*); Second Report. 1905. 2*s.* (1*s.* 6*d.*); Third Report. 1905. 1*s.* (10*d.*); Final Report. 1906. (Out of print)
- MEDICAL SERVICES OF FOREIGN ARMIES.** Handbook of.
Part I. FRANCE 6*d.* (5*d.*) | Part V. ITALY 6*d.* (5*d.*)
Part II. GERMANY 6*d.* (5*d.*) | Part VI. THE NETHERLANDS
Part III. AUSTRIA-HUNGARY. 6*d.* (6*d.*) | AND BELGIUM 6*d.* (5*d.*)
Part IV. RUSSIA 6*d.* (5*d.*)
- MEKOMETER** Handbook. 1911. 6*d.* (6*d.*)
- MESOPOTAMIA.** Report for the Army Council on. By Sir John P. Heweth, G.C.S.I., K.B.E. (With Map.) 1919. 1*s.* 6*d.* (1*s.* 3*d.*)
- MILITARY AND OTHER TERMS.** See SCHOOLS.
- MILITARY LANDS ACTS, 1892 to 1903.** Byelaws. See ARTILLERY AND RIFLE RANGES ACT, &c.
- MINE RESCUE WORK** on the Western Front. (In the press)
- MOUNTED TROOPS (DIVISIONAL) TRAINING.** June 1915. Provisional. 1*d.* (1*d.*)
- MUSKETRY REGULATIONS:**—
Part I 1909. (Reprinted, with Amendments, 1914). 6*d.* (7*d.*)
Ditto. Amendments, Nov. 1915. 1*d.* (1*d.*)
Ditto. Amendments, July 1916. Enfield 1914 pattern Rifle. 1*d.* (1*d.*)
Ditto. Addendum, July 1916. Handbook of the Enfield pattern, 1914, .303-inch Magazine Rifle. 1*d.* (1*d.*)
Ditto. Addendum No. 2, Dec. 1916. Hotchkiss Gun and Lewis Gun Courses. 1*d.* (1*d.*)
Ditto. Addendum No. 3, Dec. 1918. Instructional Course for Webley or other Pistol, with Appendix—Notes on Pistol Shooting. 2*d.* (2*d.*)
Ditto. Addendum No. 4, April 1917. Annual General Musketry Course and Musketry Course for Transport Workers Battalions. 1*d.* (1*d.*)
Ditto. and Vickers' Machine-Gun Handbook. Amendments, June 1916. Range Tables for Vickers' Guns for Mark VII. Ammunition. 1*d.* (1*d.*)
Part II. Rifle Ranges and Musketry Appliances. 1910. (Reprinted, with Amendments to Oct. 31, 1914). 4*d.* (4*d.*)
See also MACHINE GUN COMPANY TRAINING.
- NIGHT OPERATIONS.** Elementary Training in. 1911. 1*d.* (1*d.*)
- NUMBER OF TROOPS TO THE YARD** in the Principal Battles since 1850. Memo. on. With opinions of Modern Authorities on limits of extension at the present day. 1884. 3*d.* (7*d.*)
- NURSING SERVICE.** Queen Alexandra's Imperial Military. Regulations for Admission to the. 1916. 1*d.* (1*d.*)
See also HOSPITALS and TERRITORIAL FORCE.

MILITARY BOOKS, published by Authority—continued

(As to prices in brackets, see top of page 2.)

- OFFICERS DIED IN THE GREAT WAR, 1914-19:—**
 Part I. Old and New Armies. Part II. Territorial Army. 7s. 6d. (5s. 5d.)
- OFFICERS TRAINING CORPS:—**
 Regulations. 1912. (Reprinted, with Amendments to April, 1916). 2d. (2d.)
 Ditto. (Inns of Court). 1d. (1d.)
 Special A.O., March 16, 1908. 1d. (1d.)
 Junior Division. Instructions for the Annual Camps. 1913. 2d. (2d.)
- ORANGE FREE STATE TOPOGRAPHICAL SURVEY, 1905-1911.** Report on the. 10s. (7s.)
- ORDNANCE COLLEGE.** See also ARTILLERY COLLEGE.
 Advanced Classes. Reports on. (Up to the 33rd). Each 1s. (9d.)
 Ditto. Ditto. 34th. 6d. (5d.)
 Ditto. Ditto. 35th. 1s. (10d.)
- Artificers. Military. Handbook for. 10th Edition. 1915. 9d. (9d.)
 Dynamics. Notes on. Second Edition. 3s. (2s. 5d.)
 Ordnance Courses. Reports on. (Up to the 16th). Each 1s. (9d.)
 Ditto. Ditto. 17th. 9d. (7d.)
 Ditto. Ditto. 18th. 1s. 6d. (1s. 2d.)
 Ditto. Ditto. 19th. 1s. 6d. (1s. 2d.)
- Regulations. 1907. 2d. (2d.)
- ORDNANCE CORPS.** Army. Standing Orders. 1912. (Reprinted, with Amendments. 1917). 6d. (6d.)
- ORDNANCE MANUAL (WAR).** 1914. 6d. (5d.)
- ORDNANCE SERVICE.** Treatise on. Seventh Edition. 1908. With volume of plates. 7s. 6d. (5s. 6d.) Amendments. June 1909, Dec. 1910, Dec. 1912. Each 1d. (1d.); Do. Dec. 1909, Dec. 1911. Each 2d. (2d.)
- ORDNANCE SERVICES. ARMY.** Regulations:—
 Part I. 1912. (Reprinted, with Amendments up to July 1, 1915). 6d. (7d.)
 Ditto. Amendments, Jan. 1918. Appendix XII. Extract from the Regulations for Magazines, &c. 1d. (1d.)
 Ditto. Amendments, Jan. 1918. Appendix XX. 1d. (1d.)
 Part II. 1914. Instructions for Laboratories and Laboratory Operations. Examination of Explosives and Ordnance. 1914. (Reprinted, with Amendments published in Army Orders up to and including Dec. 1, 1916.) 1s. 6d. (1s. 3d.)
 Ditto. (Separately.) Amendments, Dec. 1916. (Including Appendices XI, XIV, and XV., as amended in the Regulations.) 2d. (2d.)
 Ditto. Amendments, Aug., Oct. 1917. Each 1d. (1d.)
 Ditto. Pamphlet No. 7. Land Service Cordite Regulations. 6d. (6d.)
- PATHOLOGICAL SPECIMENS** in the Museum of the Army Medical Department, Netley. Descriptive Catalogue of. Third Edition. Vol. I. By Sir W. Aitken, M.D. 1892. 5s. (3s. 3d.)
- PAY,** Appointment, Promotion, and Non-Effective Pay of the Army. Royal Warrant, 1914. (Reprinted 1913.) 1s. (1s.); Amendments, &c., published in Army Orders between Dec. 1, 1914, and Aug. 1, 1918. 9d. (9d.)
- PAY DUTIES** of Officers Commanding Squadrons, Batteries, Companies, &c. Instructions. (Revised for the period of the War). I. Home and Colonies. II. In the Field. June 1918. 2d. (2d.) See also TERRITORIAL FORCE.
- PAY FOR SOLDIERS. INCREASE OF.** Royal Warrant, Dec. 3, 1917. With the Army Council's Instructions thereon, and with Amendments to the Separation Allowance Regulations—Family Allowance. (Special Army Order, Dec. 4, 1917). 1d. (1d.)
 See also FAMILY ALLOWANCE and SEPARATION ALLOWANCE.
- PAY OF OFFICERS** and Allowance for Officers' Children. Royal Warrant, Jan. 25, 1918; with the Army Council's Instruction thereon, and Regulations. (Special Army Order, Jan. 26, 1918.) 1d. (1d.)
- PHYSICAL TRAINING.** Manual of. (Reprint 1908 with Amendments published in Army Orders to Dec. 1, 1914). 9d. (9d.)
- PHYSIOLOGY,** Elementary, in its relation to Hygiene. Feb. 1919. 2d. (2d.)
 See also HYGIENE and SCHOOLS.
- PLACE NAMES OCCURRING ON FOREIGN MAPS.** Rules for the Transliteration of. 1919. 1s. 6d. (1s. 2d.)
- PORTABLE SUB-TARGET** (Mark I), and How to Use it. 1911. (Reprinted, with Amendments, 1914). 1d. (1d.)
- POSTAL SERVICES. ARMY.** Manual of. War. 1913. (Reprinted, with Amendments, 1915). 3d. (3d.)
- PROJECTION, &c.** Linear Perspective. A Text Book for the use of the R.M. Academy. Part I—Text. Part II—Plates. 1904. 6s. (4s. 3d.)
- PROMOTION OF LIEUTENANTS** of the Army Veterinary Corps, Special Reserve, and Territorial Force. See FIELD ALLOWANCE.
- PROTRACTOR. SERVICE.** For use in Map Reading Classes. 1d. (1d.)
 See also MAP READING.
- PUBLICATIONS (RECENT) OF MILITARY INTEREST.** List of. Quarterly. Nos. 1 to 3 (except 1, 3, 5, and 6, out of print). Each 2d. (2d.) Nos. 9 to 17. Each. 4d. (4d.) Continued by THE ARMY REVIEW.
- RAILWAY DISTANCES.** Ireland. Handbook of. Third Edition. 1884. 7s. 6d. (5s. 3d.)

PUBLIC LIBRARY OF BOSTON

(As to prices in brackets, see top of page 2.)

- RAILWAY MANUAL (WAR).** 1911. (Reprinted, with Amendments, 1914). 6d. (5d.)
- RAILWAYS, MILITARY.** Reconnaissance and Survey of Notes on, for Officers of R.E. Railway Companies 1910 2s. 3d.
- RANGE-FINDER Handbooks:—**
Infantry No. 1 (Marindin). 1913. 3d. (3d.)
Do. No. 2 (Barr and Stroud). 31·5-inches base. 1916. 6d. (5d.)
- RANGES, MINIATURE CARTRIDGE.** (Reprinted from THE ARMY REVIEW). Jan. 1914). 3d. (3d.)
- RANGETAKERS.** Instructions for the Training of, with the Artillery Rangefinder. 1d. (1d.)
- RANGING.** Examples of. See ARTILLERY, TRAINING, FIELD.
- RATIONS, ARMY.** Their Bearing on the Efficiency of the Soldier. By D. Nüel Paton, M.D., F.R.S., Professor of Physiology, University of Glasgow. 3d. (3d.)
- RECRUITING FOR THE REGULAR ARMY AND THE SPECIAL RESERVE.** Regulations. 1912. (Reprinted, with Amendments to Aug. 31, 1914). 3d. (3d.)
- REMOUNT REGULATIONS.** 1913. 3d. (3d.)
- RESERVE.** (See also SPECIAL RESERVE and TERRITORIAL FORCE):
Army Reserve. Class I. Regulations. 1911. 1d. (1d.)
Ditto. Amendments, June 1913. 1d. (1d.)
National Reserve. Regulations. Provisional. 1913. 1d. (1d.)
- RIFLE, ENFIELD 1914 PATTERN.** See MUSKETRY REGULATIONS, Part I.
- RIFLE, ROSS MAGAZINE.** .303-inch, Mark IIIb. Handbook of the. 1915. (Reprinted with Amendments, 1917.) 1d. (1d.)
- RIFLES, &c.** Cleaning of. Notes on the. 1911. 25 for 6d. (7d.)
- RIFLES, SHORT AND CHARGER-LOADING, MAGAZINE, LEE-ENFIELD.** Handbook for Serjeant-Instructors of Special Reserve, Officers Training Corps, and Territorial Force in regard to the Care, Inspection, &c., of. 3d. (3d.)
- RUSO-JAPANESE WAR:—**
Medical and Sanitary Reports from Officers attached to the Japanese and Russian Forces in the Field. 1908. 5s. (3s. 10d.)
Official History. Part I. Causes of the War. Opening Events up to and including the Battle of the Ya-lu. Second Edition. 1909. 1s. 6d. (1s. 3d.); Part II. From the Battle of the Ya-lu to Liao-yang, exclusive. 1908. 5s. (3s. 8d.)
Part III. The Siege of Port Arthur. 1909. 4s. 6d. (3s. 4d.); Part IV. Liao-yang. 1910. 4s. (3s.); Part V. Sha Ho. 1911. 4s. 6d. (3s. 5d.)
Official History (Naval and Military). Vol. I. To Aug. 24, 1904. With case of Maps. 1910. 15s. (10s. 7d.); Vol. II. Liao-yang, the Sha Ho, Port Arthur. With case of Maps. 1912. 15s. (10s. 10d.)
Reports from British Officers attached to the Japanese and Russian Forces in the Field. In three Vols., with two cases of Maps (not sold separately). 21s. (15s.)
- SALISBURY PLAIN. SOUTHERN COMMAND.** Standing Orders applicable to all Troops Encamped on Salisbury Plain, and applicable generally to Troops Quartered at Bulford and Tidworth. 1913. (Reprinted, with Amendments, 1915). 3d. (3d.)
- SCABIES.** See MEDICAL SERVICE.
- SCHOOLS. Army:—**
Annual Reports on. 1911-12; 1912-13. Each 1s. (9d.)
Military and other Terms, and Words which Occur in Orders Lists of. 1914. (Reprinted 1918). 3d. (3d.)
Physiology. Elementary. Handbook. 1901. 1d. (1d.)
See also HYGIENE; PHYSIOLOGY; and (below) SCHOOL HYGIENE.
Regulations. 1911. 4d. (4d.)
School Hygiene. Handbook of. For Teachers. 1907. 6d. (6d.)
See also HYGIENE; PHYSIOLOGY; and (above) PHYSIOLOGY.
Singing in. Regulations for Teaching. 1911. 1d. (1d.)
Standing Orders for Inspectors, Examiners, Teachers. 1910. 6d. (5d.)
Type Exercises of Extracts from Regimental Orders for use of Candidates or Third-class Certificates of Education. 1912. 3d. (3d.)
- SCOUTS.** Training and Use of. Lecture by Col. F. C. Carter. 1905. 2d. (2d.)
- SCREWS.** Standard Leading. Provision of, for Screw-cutting Lathes. Report of Committee. 1905. 1s.
- SEPARATION ALLOWANCE, ALLOTMENTS OF PAY, AND FAMILY ALLOWANCE. ARMY.** Regulations for the Issue of. 1918. 6d. (6d.)
See also FAMILY ALLOWANCE and PAY FOR SOLDIERS.

MILITARY BOOKS, published by Authority—continued.

(As to prices in brackets, see top of page 2.)

SERVICE CORPS. ARMY:—

- Regimental Standing Orders. 1911. (*Out of print*); Amendments. 1*d.* (1*d.*);
A.S.O. Memorandum No. 26. 1*d.* (1*d.*)
Soldiers' Pay Schedule. (Reprinted, with Amendments to April 1919). 1*s.* 6*d.* (1*s.* 2*d.*)
Training. Part I. 1909. (Reprinted, with Amendments, 1915). 9*d.* (9*d.*)
Ditto. Part II. Supplies. 1909. (Reprinted 1914, with new Appendix XII.)
1*s.* 3*d.* (1*s.* 1*d.*)
Ditto. Part III. Transport. 1911. (Reprinted, with Amendments to April
1915). 9*d.* (9*d.*)
Ditto. Part IV. Mechanical Transport. (*Out of print*)

SEVASTOPOL. Siege of. 1854-55. 3 vols., with Case of Maps and Plans. Half
Morocco, £5 4*s.* Cloth, £4 4*s.*

Or separately.—Vol. I. Engineer Operations. £1 6*s.*; Vol. II. Ditto. With
Case of Maps and Plans. £2 10*s.*; Vol. III. Artillery Operations. 10*s.*

SEWAGE. Practical Treatment of. The latest development of. 1903. 6*d.* (5*d.*)

SHOEBURYNES GARRISON. Standing Orders. 1913. 1*s.* 6*d.* (1*s.* 1*d.*)

SIEGE OPERATIONS in the Campaign against France, 1870-71. (*Von Tiedemann.*)
Translated. 4*s.* 6*d.* (3*s.* 3*d.*)

SIGNAL SERVICE. THE ARMY. 1*d.* (1*d.*)

SIGNAL SERVICE. ARMY. MANUAL OF—WAR. PROVISIONAL.
1914. 2*d.* (2*d.*)

SIGNAL TRAINING:—

Part I. 1919. Visual Telegraphy 1*s.* (11*d.*)

Part VI. 1918. Procedure. 1*s.* (10*d.*)

SMALL WARS. Their Principles and Practice. Third Edition. 1906. (*Reprinted,*
1909). 4*s.* (3*s.*)

SOLDIERS, DISABLED AND DISCHARGED, IN FRANCE. See **DISABLED.**

SOMALILAND:—

Military Report on. 1907. Vol. I. Geographical, Descriptive, and Historical. 2*s.*
(1*s.* 7*d.*)

Operations in, 1901-04. Official History. Vol. I. 3*s.* (2*s.* 4*d.*); Vol. II. 4*s.* (3*s.*)

SOUTH AFRICAN WAR, 1899-1902:—

Medical Arrangements. 7*s.* 6*d.* (5*s.* 6*d.*)

Medical History. An Epidemiological Essay. (Reprinted from "The Journal of
the Royal Army Medical Corps.") 3*s.* 9*d.* (2*s.* 9*d.*)

Railways. 4*s.* (3*s.*)

Surgical Cases Noted. 7*s.* 6*d.* (5*s.* 6*d.*)

Telegraph Operations. 10*s.* (7*s.* 1*d.*)

Voluntary Organizations in aid of the Sick and Wounded. Report of the Central
British Red Cross Committee on. 1902. 3*s.* (2*s.* 5*d.*)

SPECIAL RESERVE. See also **ENTRANCE; EXAMINATION; and RESERVE.**

Regulations for Officers of the Special Reserve of Officers, and for the Special
Reserve. 1911. 4*d.* (5*d.*)

Scheme for the Provision, Organization, and Training of the Special Reserve
required to supplement the Regular Army, and the Application of the Scheme
to the existing Militia. (Special A.O., Dec. 23, 1907.) 2*d.* (2*d.*)

STAFF COLLEGE (Camberley). Regulations. 1905. Reprinted with Amendments
up to Nov. 30, 1910. 1*d.* (1*d.*)

**STATIONS OF UNITS OF THE REGULAR FORCES, MILITIA,
SPECIAL RESERVE, AND TERRITORIAL FORCE.** Quarterly up to No. 45,
July 1914. Each 2*d.* (2*d.*) (*Subsequent Publication suspended*)

STATUTES relating to the War Office and to the Army. 1880. 5*s.* (3*s.* 9*d.*)

STATUTORY POWERS of the Secretary of State, Ordnance Branch. 1879. 5*s.*
(3*s.* 9*d.*)

STEAM ENGINES AND BOILERS, AND GAS AND OIL ENGINES.

Notes and Memoranda on the Management of. 1911. 1*d.* (1*d.*)

SUDAN ALMANAC. 1920. Compiled in the Intelligence Department, Cairo.
Astronomical Calculations made in the Computation Office of the Survey Depart-
ment, Egyptian Ministry of Finance. 1*s.* (10*d.*)

SUDAN. THE BRITISH FORCE IN THE. Standing Orders. 1914. 9*d.* (7*d.*)

SUDAN. The Anglo-Egyptian. A Compendium prepared by Officers of the Sudan
Government:—

Vol. I. Geographical, Descriptive, and Historical (*with Eighty-two Illustrations*). 10*s.* (7*s.* 4*d.*)

Vol. II. Routes. 7*s.* 6*d.* (5*s.* 5*d.*) (*Not including Chapter VII., Supplement (A).*)

Ditto. In Separate Chapters. 1*s.* (10*d.*) each:—

I. and II., Nil. III. North-Eastern Sudan. IV. Eastern Sudan. V. Central
Sudan. VI. South-Eastern Sudan. VII. Bahr-el-Ghazal. VIII. Kordofan.

IX. North-Western Sudan.

Ditto. Chapter VII. Supplement (A). Bahr-el-Ghazal. Additional Routes. 1*s.*
(10*d.*)

MILITARY BOOKS, published by Authority—continued.

(As to prices in brackets, see top of page 2.)

- SUDAN CAMPAIGN.** History of the. In two parts with case of Maps. 1890. 15s. (10s. 11d.)
- SUPPLY MANUAL (WAR).** 1909. 6d. (6d.)
- SUPPLY. REORGANIZED SYSTEMS OF,** and of Ammunition Supply of the Expeditionary Force in War, consequent on the introduction of Mechanical Transport. Memorandum explaining the. Feb. 1912. 1d. (1d.)
- SUPPLY, TRANSPORT, AND BARRACK SERVICES.** Regulations. 1915. 6d. (6d.)
- SURVEYING.** Topographical and Geographical. Text Book of. Second Edition. 1913. 7s. 6d. (5s. 6d.)
- Ditto. 1905. Appendix XI. Tables for the Projection of Graticules for squares of 1° side on scale of 1: 250,000, and for squares of ½° side on scale of 1: 125,000; with other Tables used in Projection Maps. 4d. (4d.)
- Ditto. 1905. Appendix XII. Tables for the Projection of Graticules for maps on the scale of 1: 1,000,000. 1910. 2d. (2d.)
- TACTICAL RIDES AND TOURS ON THE GROUND.** The Preparation and Conduct of. Translated from the German. 1s. 3d. (1s. 1d.)
- TANK TRAINING.** Vol. I. (In the press)
- TELEGRAPHY AND TELEPHONY.** Army. Instruction in:—
- Vol. I. Instruments. 1908. (Reprinted, with Corrections, 1914). 1s. 6d. (1s. 4d.)
- Vol. II. Lines. 1909. (Reprinted, with Corrections, 1914) 1s. (11d.)
- Ditto. Revised Chapter I. Field Cables. Provisional. 1d. (1d.)
- Ditto. Amendment, April 1918. Revised para. 67. 1d. (1d.)
- TERRITORIAL FORCE.** See also EQUIPMENT and EXAMINATION.
- Cadet Infantry Training. Manual of. (In the press)
- Cadet List. A List of Cadet Units which have received official recognition up to June 30, 1918. 4s. (2s. 11d.)
- Cadet Units in the British Isles. Regulations governing the Formation, Organization and Administration of. 1914. (Reprinted, with Amendments in Army Orders to March 1, 1918). 1d. (1d.)
- Field Kits. Officers and Men. 1d. (1d.)
- Hospitals, General, of the. Regulations for. 1912. 2d. (8d.)
- Medical Corps, Royal Army. Syllabus of Training. 1914. 1d. (1d.)
- Mobilization of a Territorial Infantry Battalion. (Reprinted from THE ARMY REVIEW, July 1913). 3d. (3d.)
- Nursing Service. Standing Orders. 1912. (Reprinted, with Amendments, 1914). 1d. (1d.) See also HOSPITALS and NURSING SERVICE.
- Pay Duties during Embodiment. Instructions in. 2d. (2d.)
- Regulations for the (including the Territorial Force Reserve), and for County Associations. 1912. (Reprinted, with Amendments published in Army Orders to Dec. 1, 1914). 6d. (7d.)
- Voluntary Aid:—
- Scheme for the Organization of, in England and Wales. Dec. 1910. (Out of print)
- Ditto. Amendments. 1d. (1d.)
- Ditto. in Scotland. Oct. 1911. 2d. (2d.)
- Ditto. Amendments. 1d. (1d.)
- TRACTOR TRIALS** held by the Experimental Sub-Committee of the Mechanical Transport Committee at Aldershot, Sept. and Oct. 1903. Report on. 6d. (5d.)
- TRAINING AND MANŒUVRE REGULATIONS.** 1913. 4d. (5d.)
- TRANSPORT. MECHANICAL:—**
- Heavy Pontoon Bridge for use by. 1914. Provisional. 2d. (2d.)
- Regulations for the Appointment of Inspectors of. 1d. (1d.)
- TRANSPORT. PACK.** Notes on. (Reprinted with Amendments, 1916). 1d. (1d.)
- TROOPS.** See MOUNTED and NUMBER.
- TRUMPET AND BUGLE SOUNDS** for the Army. With Instructions for the Training of Trumpeters and Buglers. 1914. 9d. (8d.); Amendments, July 1917. 1d. (1d.)
- TYPE EXERCISES.** See SCHOOLS.
- TYPHOID (ANTI-) COMMITTEE.** Report. 1912. 2s. 6d. (1s. 11d.)
- TYPHOID (ANTI-) INOCULATION COMMITTEE.** Report on Blood Changes following Typhoid Inoculation. 1905. 1s. 6d. (1s. 2d.)

MILITARY BOOKS, published by Authority—continued.

(As to prices in brackets, see top of page 2.)

URDU-ENGLISH PRIMER. For the use of Colonial Artillery. 1899. 15s. (10s. 2d.)

VALISE EQUIPMENT. Instructions for Fitting :—
Bandoller pattern. 1903. 2d. (2d.)

See also EQUIPMENT.

VALPARAISO. The Capture of, in 1891. 1s. (10d.)

VENEREAL DISEASE. *See* MEDICAL SERVICES.

VETERINARY CORPS. Army. Standing Orders. 1906. 4d. (4d.)

VETERINARY MANUAL (WAR). 1915. 1d. (1d.)

VETERINARY SERVICES. Army. Regulations. 1906. (Reprinted, with Amendments to Dec. 31, 1917). 3d. (3d.)

VOLUNTARY AID. *See* TERRITORIAL FORCE.

VOLUNTEER ACTS, 1863, 1869, 1895, 1897, and 1900, except where repealed Reprint of; Extracts from Regulation of the Forces Acts, 1871 and 1881, and Reserve Forces Act, 1890; and Order in Council of Feb. 5, 1872. 1d. (1d.)

WAR GRAVES COMMISSION. IMPERIAL:—

The Graves of the Fallen. Descriptive Account, by Mr. Rudyard Kipling, of the Work of the Commission; Illustrations, by Mr. Douglas Macpherson, showing the Cemeteries and Memorials as they will appear when completed. 6d. (6d.)

War Graves. How the Cemeteries Abroad will be Designed. Report by Lieut.-Colonel Sir Frederick Kenyon, K.C.B., Director of the British Museum. 3d. (3d.)

WAR OF 1914-18:—

Despatches (Naval and Military) relating to Operations in the War:—

- I. Sept., Oct., and Nov. 1914. With List of Honours and Rewards Conferred. With Sketch Map. (2d.) (3d.)
- II. Nov. 1914 to June 1915. With Names of Officers mentioned and Awards of the Victoria Cross. 6d. (7d.)
- III. July to Oct. 1915. With Names of Officers and Men mentioned, and Awards of the Victoria Cross. 3d. (3d.)
- IV. Dec. 11, 1915. From General Sir Ian Hamilton, G.C.B., describing the Operations in the Gallipoli Peninsula, including the Landing at Suvla Bay. 2d. (2d.)
- V. Jan. to April 1916. With Names of Officers and Men mentioned, and Awards of the Victoria Cross. 6d. (6d.)
- VI. May to Dec. 1916. With Names of Officers and Men Awarded the Victoria Cross. 1s. (1s.)
- VII. Dec. 1916 to July 1917. With Names of Officers and Men Awarded the Victoria Cross. 9d. (8d.)
- VIII. July 1917 to June 1918. With Names of Officers and Men Awarded the Victoria Cross. 1s. 6d. (1s. 4d.)
- IX. July to Dec. 1918. With Names of Officers and Men Awarded the Victoria Cross. 1s. (10d.)
- X. Jan. 1919 to Jan. 1920. With Names of Officers and Men awarded the Victoria Cross. 2s. (1s. 9d.)

Parliament's Vote of Thanks to the Forces. Speeches delivered in the Houses of Parliament, Westminster, on Oct. 29, 1917. 1d. (1d.)

WAR OFFICE LIST, AND ADMINISTRATIVE DIRECTORY FOR THE BRITISH ARMY. 1920. Sold by Harrison & Sons, 44 to 47, St. Martin's Lane, W.C. 2. 30s. net.

WOMEN'S WAR WORK in maintaining the Industries and Export Trade of the United Kingdom. Information officially compiled for the use of Recruiting Officers, Military Representatives, and Tribunals. Sept. 1916. Illustrated. 1s. (1s.)

WORKS MANUAL. (WAR). 1913. Provisional. 4d. (4d.); Appendix I. 1914. 1d. (1d.)

WOUNDS OF WAR. General Principles guiding the Treatment of. Conclusions adopted by the Inter-Allied Surgical Conference held in Paris, March and May, 1917. 2d. (2d.)

YEOMANRY AND MOUNTED RIFLE TRAINING. Parts I. and II. 1912. (Reprinted, with Amendments, 1915). 6d. (6d.)

ZULU WAR OF 1879. Narrative of the Field Operations connected with the. 1881. (Reprinted 1907.) 3s. (2s. 4d.)

ORDNANCE, B.L. 6-INCH 26-CWT. HOWITZER, WIRE, MARK I.

Scale = $\frac{1}{17}$.

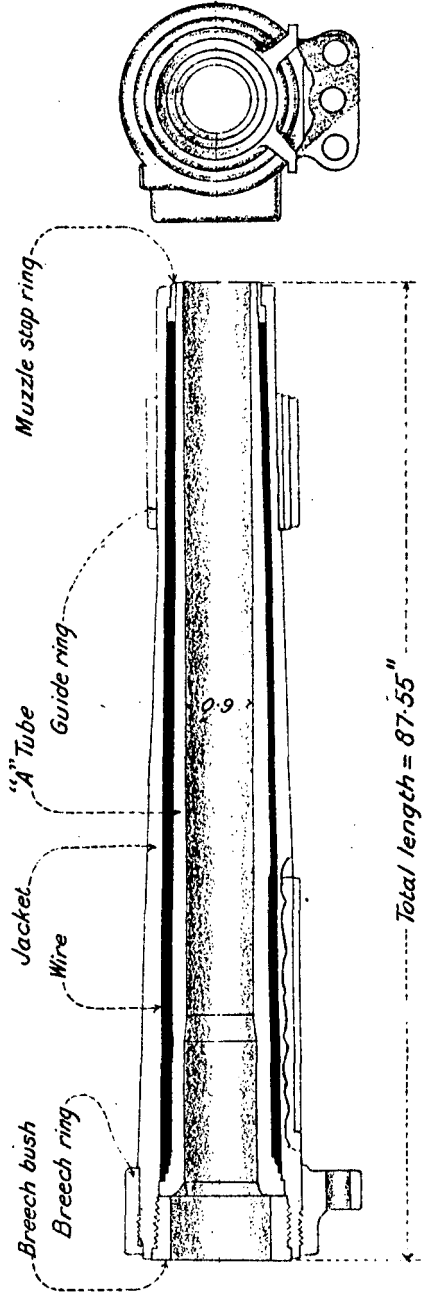

ORDNANCE, B. L. 6-INCH 26-CWT., HOWITZER, WIRE, MARK I.

General arrangement of Breech Mechanism With Martini-Metford percussion lock.

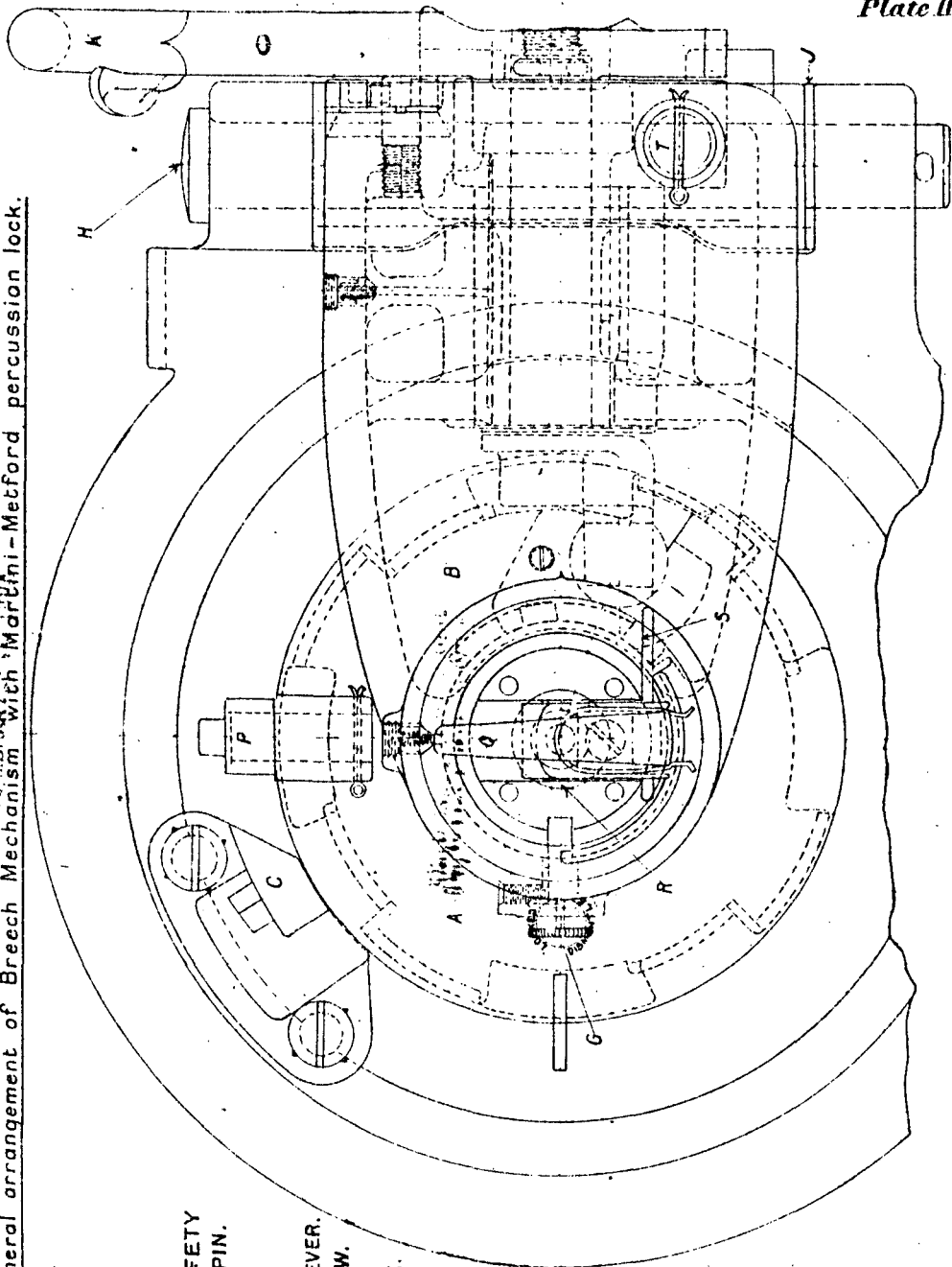

- A. BREECH SCREW.
- B. CARRIER.
- C. ROTATING CAM.
- G. VENT AXIAL NUT & SAFETY SHUTTER RETAINING PIN.
- H. CARRIER HINGE PIN.
- J. BEARING WASHER.
- K. BREECH MECHANISM LEVER.
- P. ROLLER BREECH SCREW.
- Q. COCKING LEVER.
- R. MARTINI-METFORD LOCK.
- S. FIRING PEG.
- T. SCREW SECURING BREECH MECHANISM LEVER.
- U. BEARING MARK II (ALSO FIRING LANYARD FAIRLEAD STUD).

ORDNANCE, B.L. 6-INCH, 26-CWT., HOWITZER, WIRE, MARK I.
General arrangement of breech mechanism with Martini-Metford percussion lock.

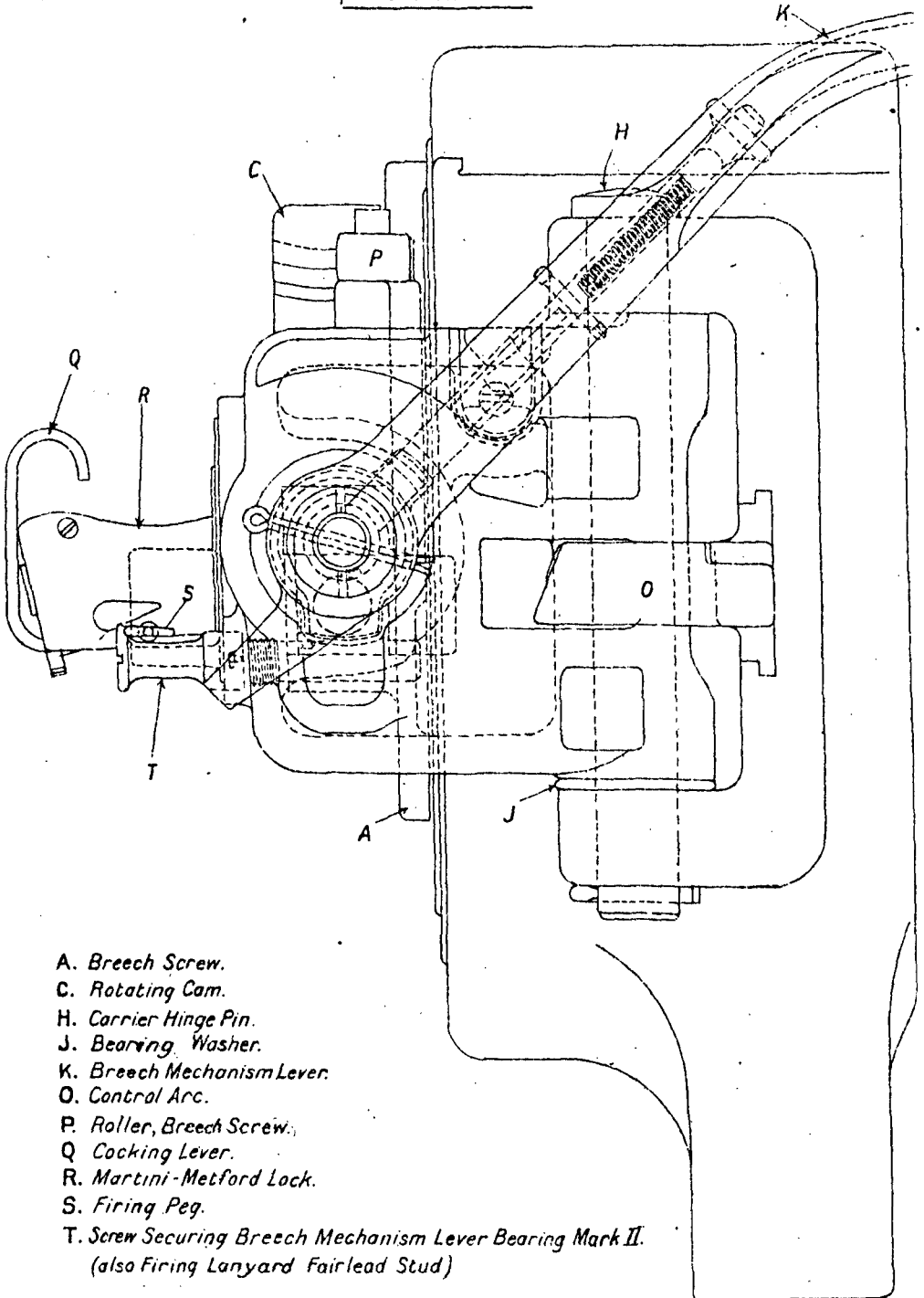

- A. Breech Screw.
- C. Rotating Cam.
- H. Carrier Hinge Pin.
- J. Bearing Washer.
- K. Breech Mechanism Lever.
- O. Control Arc.
- P. Roller, Breech Screw.
- Q. Cocking Lever.
- R. Martini-Metford Lock.
- S. Firing Peg.
- T. Screw Securing Breech Mechanism Lever Bearing Mark II.
 (also Firing Lanyard Fairlead Stud)

GENERAL ARRANGEMENT OF BREECH MECHANISM WITH MARTINI-METFORD PERCUSSION LOCK.

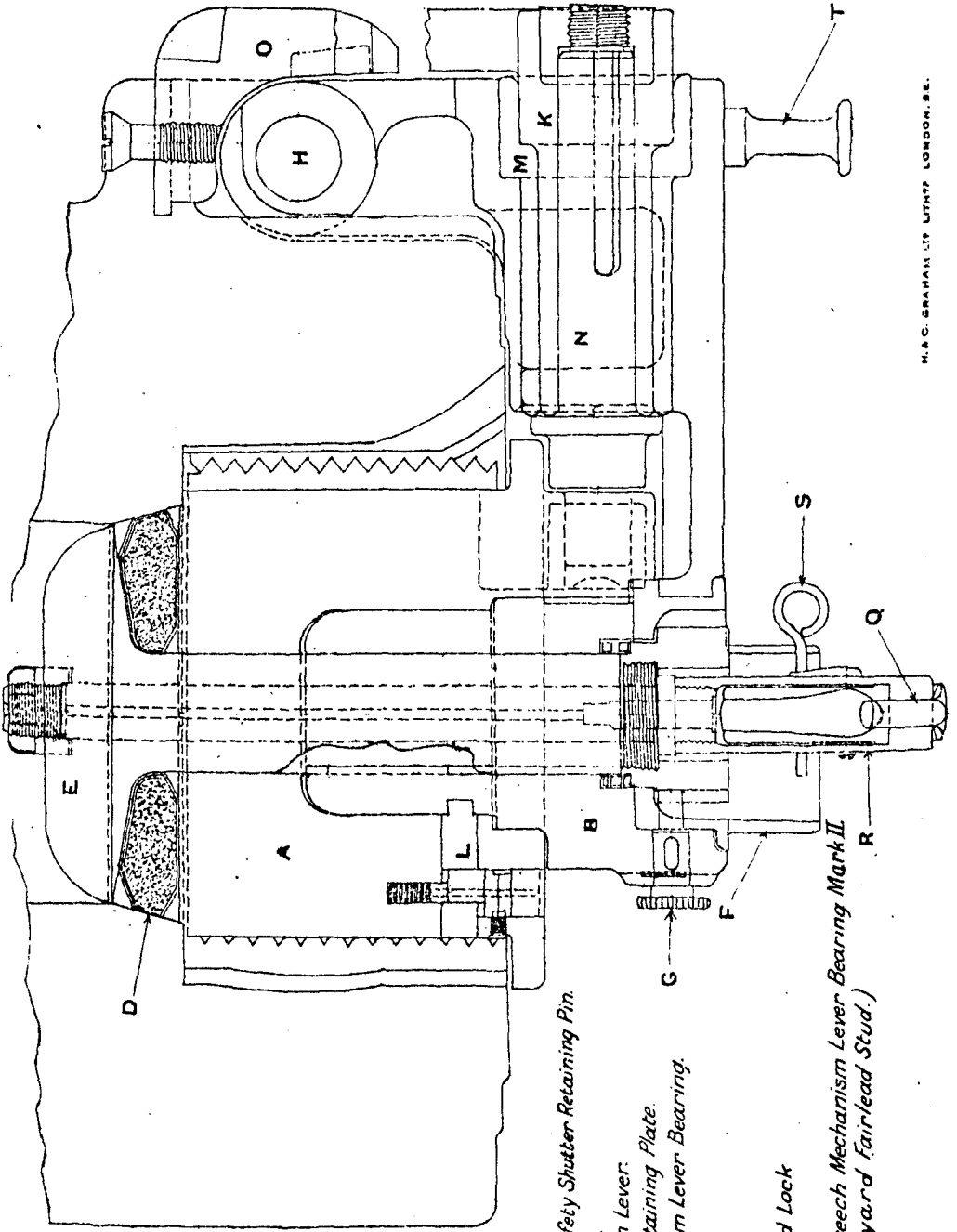

- A Breech Screw.
- B Carrier.
- D Obturator.
- E Vent Axial.
- F Safety Shutter
- G Vent Axial Nut & Safety Shutter Retaining Pin.
- H Carrier Hinge Pin.
- K Breech Mechanism Lever.
- L Breech Screw Retaining Plate.
- M Breech Mechanism Lever Bearing.
- N Crank Shaft.
- O Control Arc.
- Q Cocking Lever.
- R Martini-Metford Lock
- S Firing Peg
- T Screw Securing Breech Mechanism Lever Bearing Mark II.
(also firing lanyard fairlead stud.)

ORDNANCE. B. L. 6-INCH 26-CWT. HOWITZER, WIRE, MARK I.
GENERAL ARRANGEMENT OF FIRING MECHANISM WITH LOCK, PERCUSSION, "P.H." & BOX, SLIDE, "V"

TYPICAL.

SCALE = 1/2.

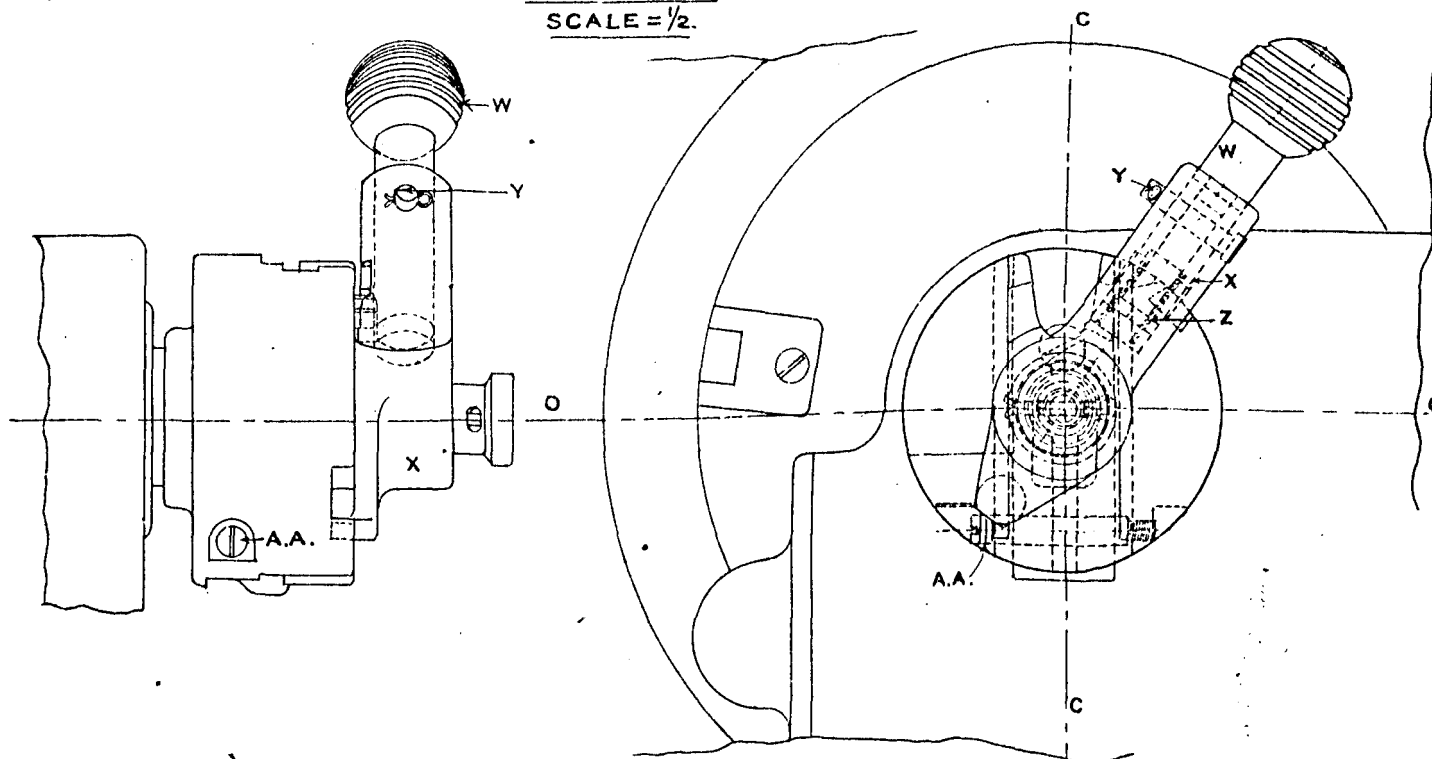

- W. Retaining catch plunger.
- X. Lock actuating lever.
- Y. Retaining catch guide pin.
- Z. " " spring.
- AA. Extractor axis screw.
- BB. Firing hole bush.

LANYARD, FIRING, N° 33.

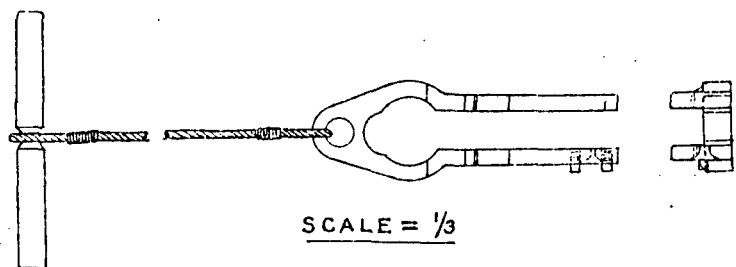
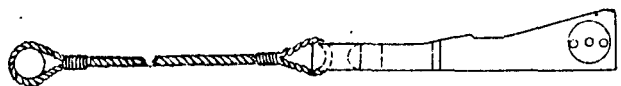

SCALE = 1/3

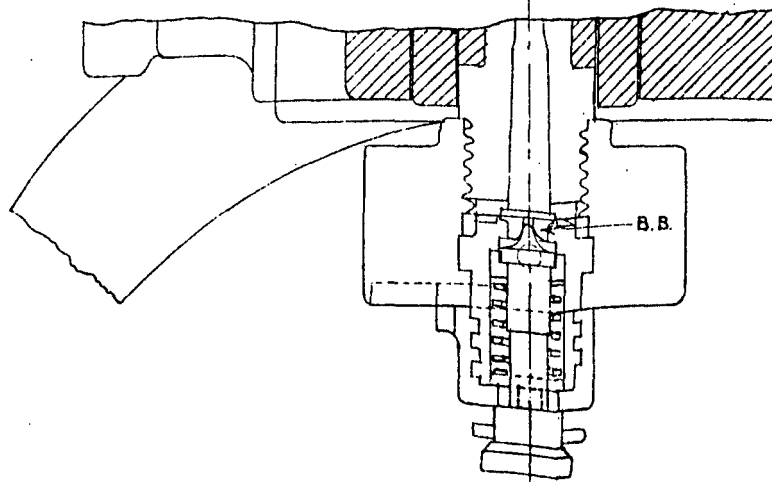

SECTION AT O.O.

**CORRIGENDA No. 1 TO HANDBOOKS FOR
THE FOLLOWING EQUIPMENTS.**

B.L. 6-inch 26-cwt. Howitzer, Mark I, on Mark I Travelling Carriages (Plate VI).

B.L. 8-inch Howitzers, Marks VI to VIII, on Travelling Carriages (Plate VIII).

B.L. 9.2-inch Howitzers, Marks I and II, on Siege Carriages (Plate VIII).

For "F.F.-Striker collar"
Read "F.F.-Rebound collar."

For "G.G.-Rebound collar"
Read "G.G.-Main spring collar."

The above-mentioned Plates should also be amended to show the position of reference "G.G." as per sketch below:—

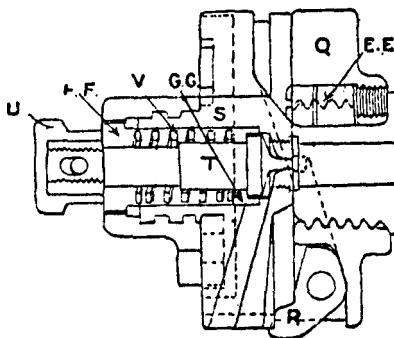

Issued, January, 1921.

ORDNANCE, B.L. 6-INCH. 26-CWT. HOWITZER, WIRE, MARK I.
 GENERAL ARRANGEMENT OF FIRING MECHANISM WITH LOCK, PERCUSSION, "P.H." & BOX, SLIDE, "V"
 TYPICAL.

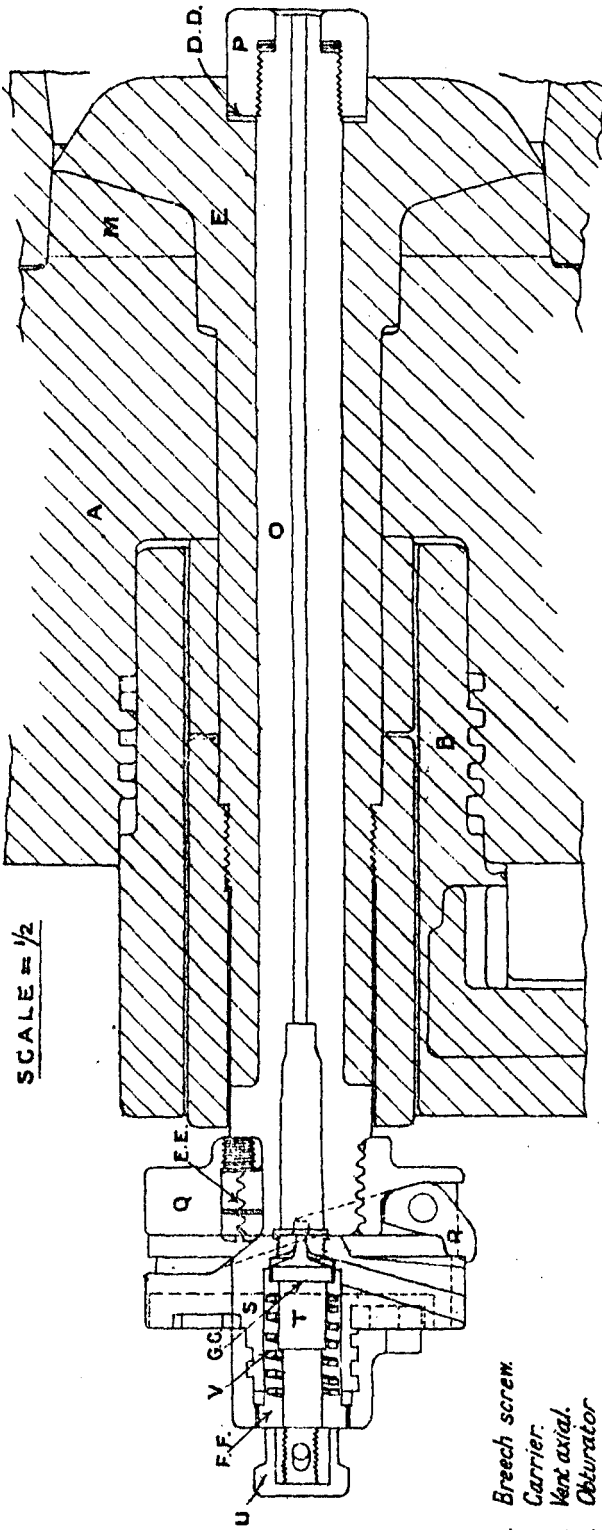

SCALE = 1/2

SECTION AT C.C. (SEE PLATE V.)

A. Breech screw.

B. Carrier.

E. Vent axial.

M. Obturator

O. Vent bush spindle

P. Nut "V"

Q. Box, slide, "V"

R. Extractor lever

S. Lock, percussion, P.H.

T. Striker.

U. Cap.

V. Main spring

DD. Washer, vent bush spindle

EE. Securing screw, box slide "V"

FF. Striker collar.

GG. Rebound collar.

CARRIAGE, TRAVELLING, B. L. 6 INCH 26 CWT. HOWITZER, MARK I.

SCALE = 1/18

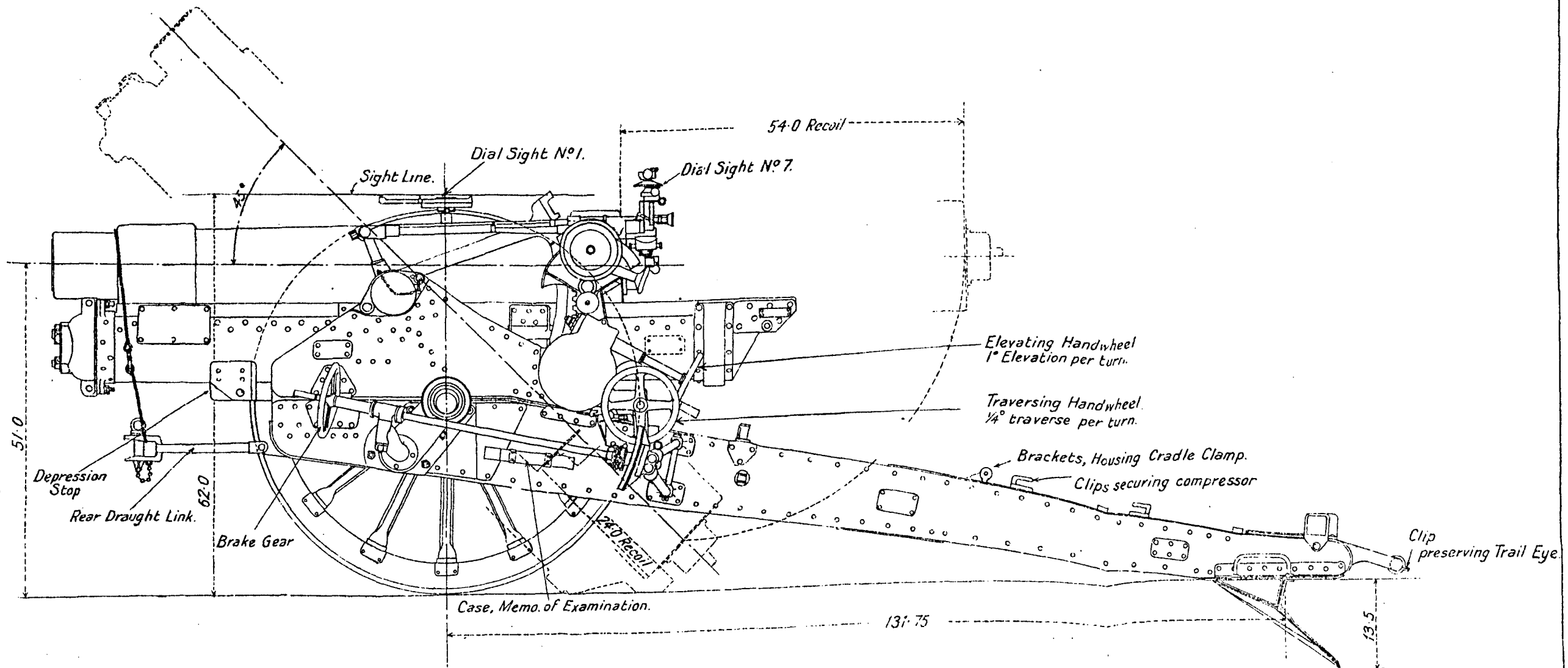

CARRIAGE, TRAVELLING, B.L. 6 INCH 26 CWT, HOWITZER. MARK I.

SCALE - 1/8.

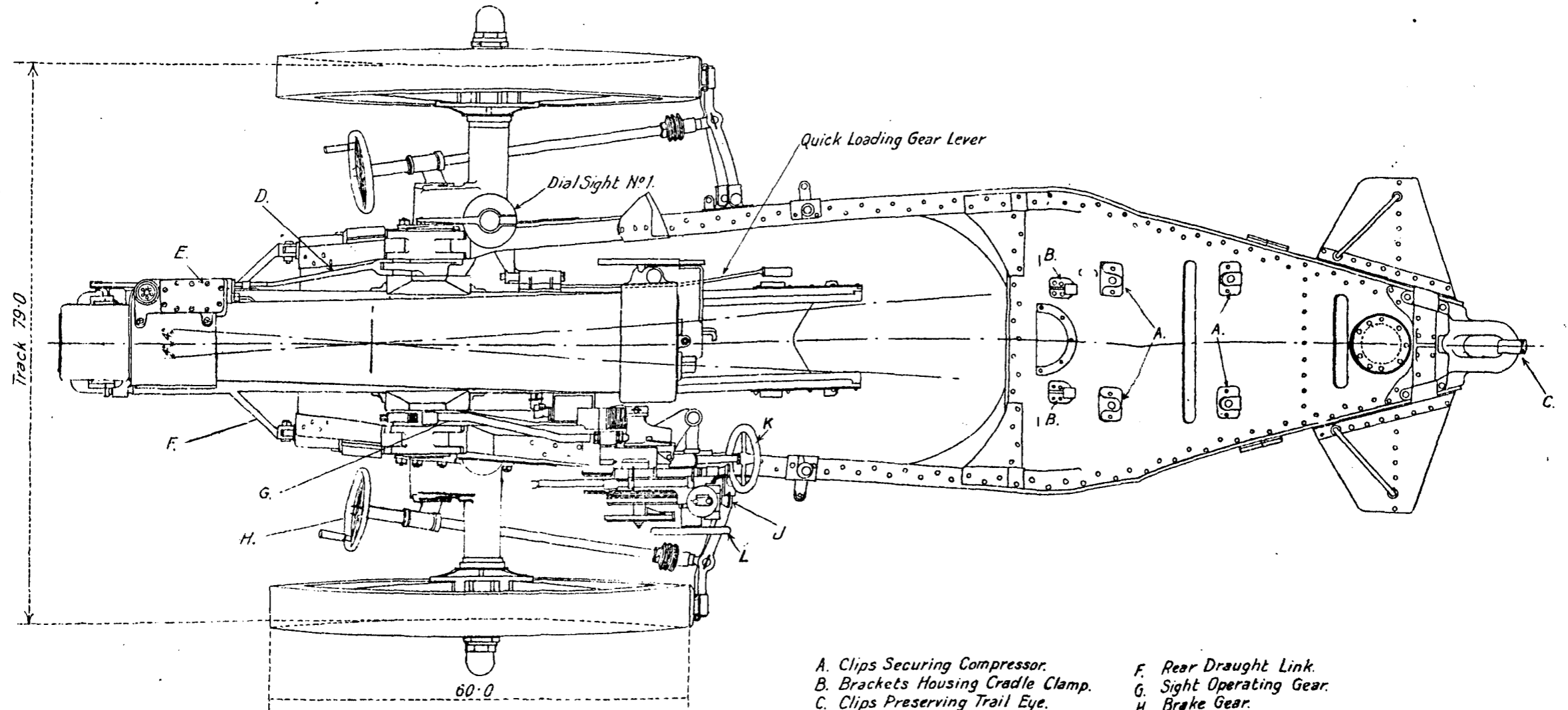

- | | |
|-----------------------------------|------------------------------|
| A. Clips Securing Compressor. | F. Rear Draught Link. |
| B. Brackets Housing Cradle Clamp. | G. Sight Operating Gear. |
| C. Clips Preserving Trail Eye. | H. Brake Gear. |
| D. Cut-Off Gear. | J. Dial Sight, No 7. |
| E. Gravity Tank. | K. Elevating Gear Handwheel. |
| | L. Traversing " " |

B.L. 6-INCH 26-CWT. MARK I HOWITZER, ON TRAVELLING CARRIAGE, MARK I.
SHOWING BREECH MECHANISM FITTED FOR FRICTION FIRING NOTE.—MARTINI-METFORD OR "P.H." PERCUSSION LOCK IS NOW FITTED.

[PLATE IX.]

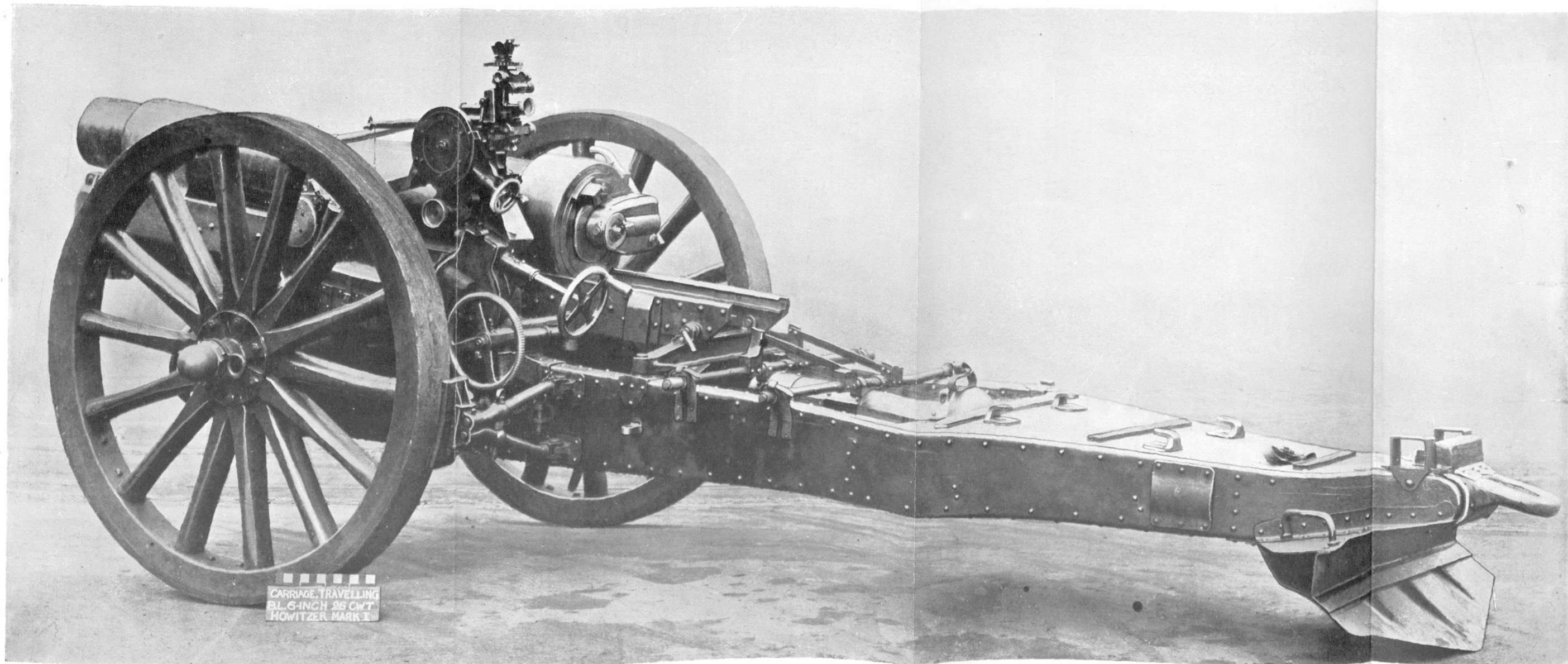

CARRIAGE, TRAVELLING
B.L. 6-INCH 26 CWT
HOWITZER MARK I

B.L. 6-INCH 26-CWT. MARK I HOWITZER, ON TRAVELLING CARRIAGE, MARK I.
SHOWING BREECH MECHANISM FITTED FOR FRICTION FIRING. NOTE.—MARTINI-METTFORD OR "P.H." PERCUSSION LOCK IS NOW FITTED.

[PLATE X.]

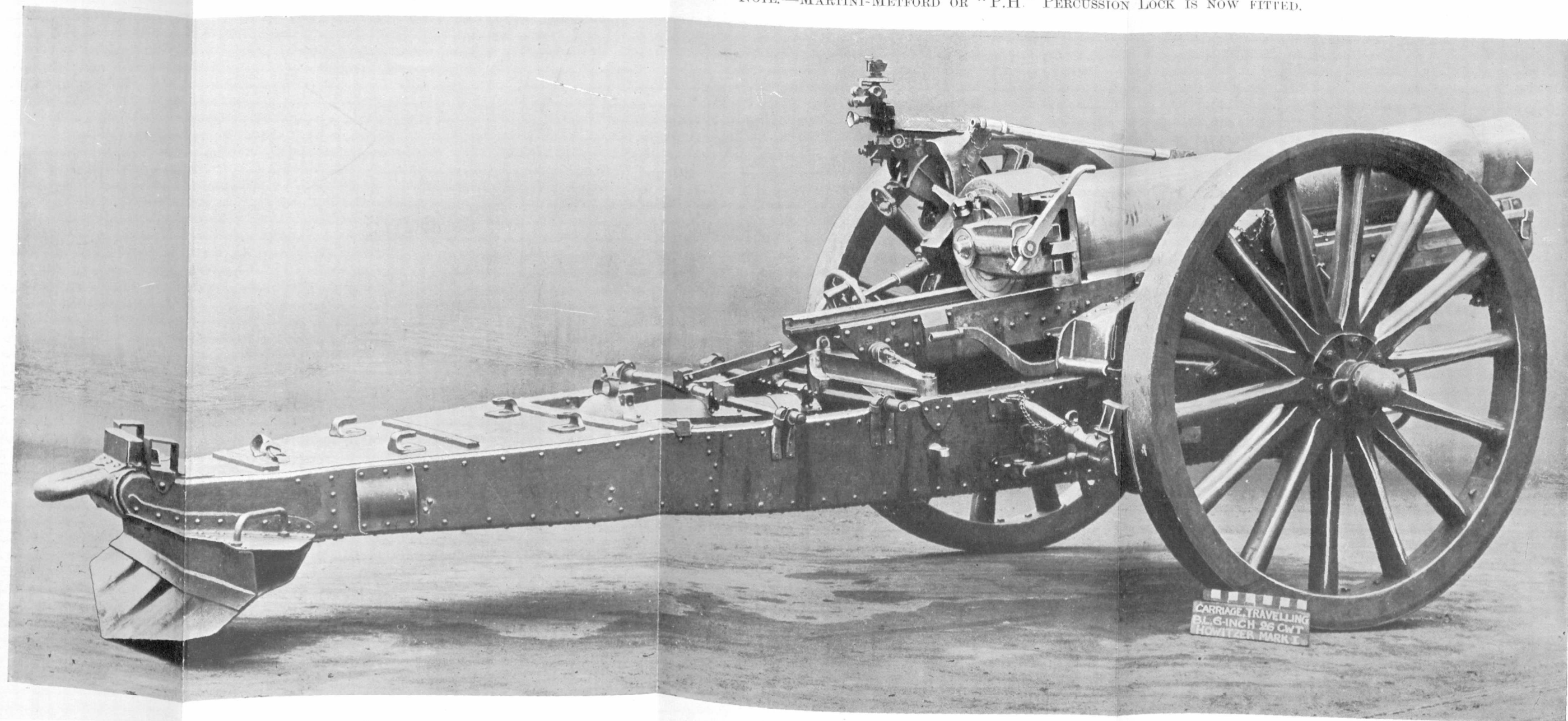

B.L. 6-INCH 26-CWT. MARK I HOWITZER, ON TRAVELLING CARRIAGE, MARK I.

[PLATE XI.]

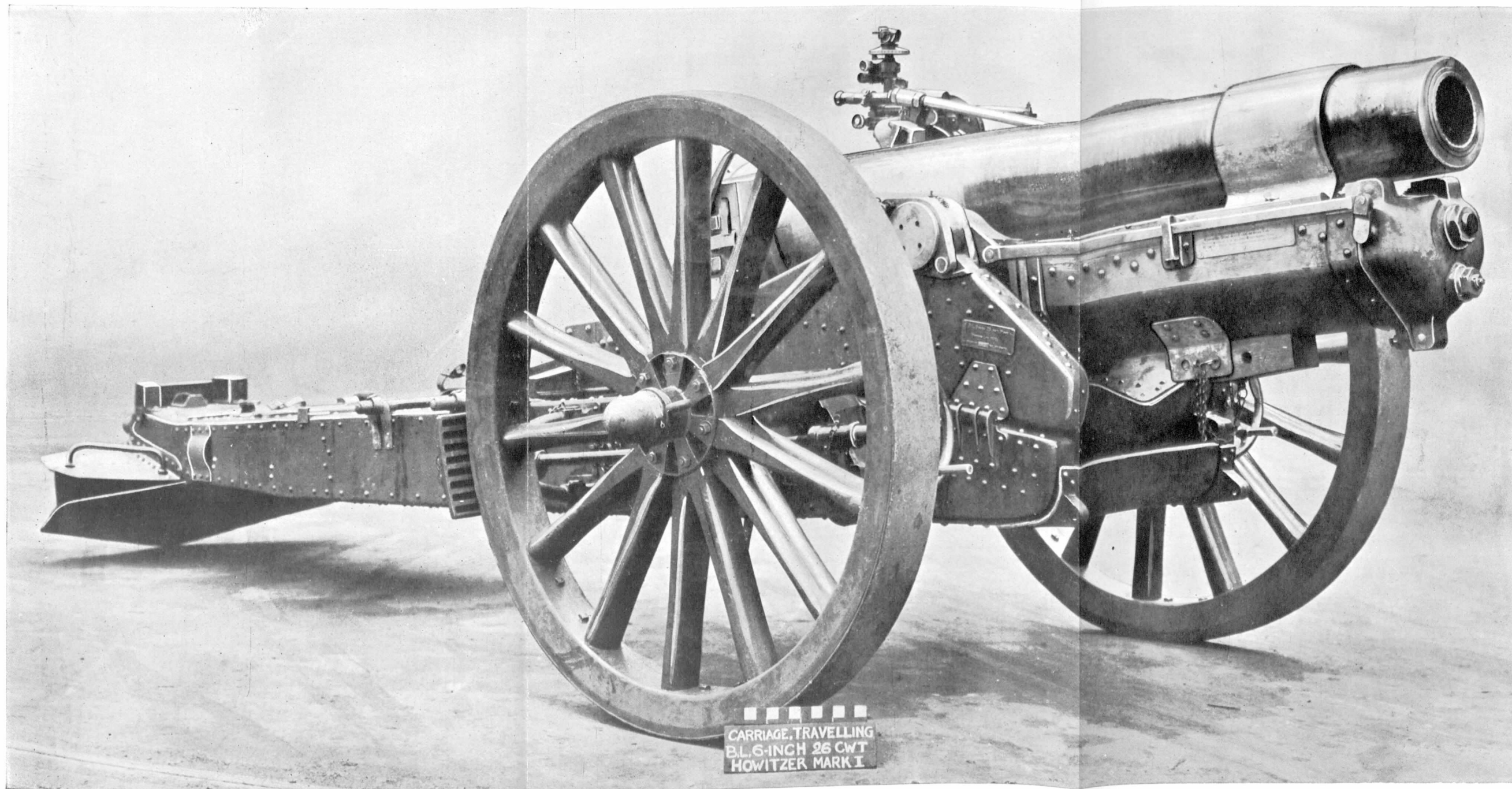

CARRIAGE, TRAVELLING, B. L. 6-INCH 26-CWT. HOWITZER.
GENERAL ARRANGEMENT OF BRAKE GEAR.

- A. Arms, brake.
- B. Shoe, brake block.
- C. Brake block.
- D. Bearing, swivel, brake nut.
- E. Bracket, swivel bearing.
- F. Carrier, springs.
- G. Nut, brake screw.
- H. Screw, brake.
- J. Spring discs.
- K. Handwheel.
- L. Pin connecting spring carrier.
- M. Pin housing brake screw.

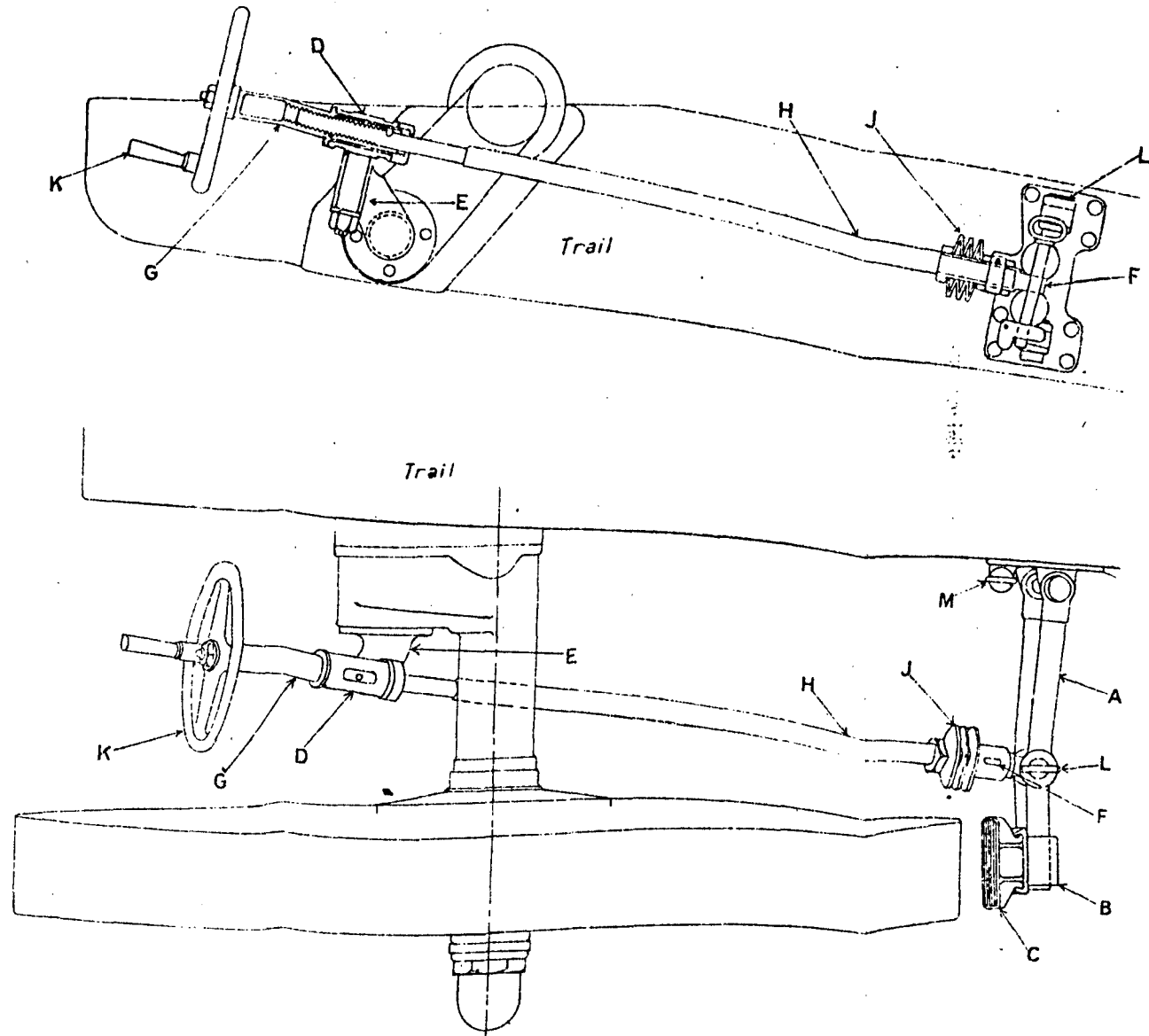

CARRIAGE, TRAVELLING, B. L. 6-INCH 26-CWT. HOWITZER.
METHOD OF ASSEMBLING GIRDLES



1st OPERATION.



Loosen all Wing Nuts and detach Wood Shees from Channels.

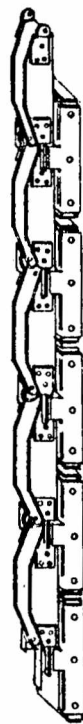

2nd OPERATION:-

Connect the two lengths of Channels by inserting the Spring Washers and Pins, thus making one continuous length.

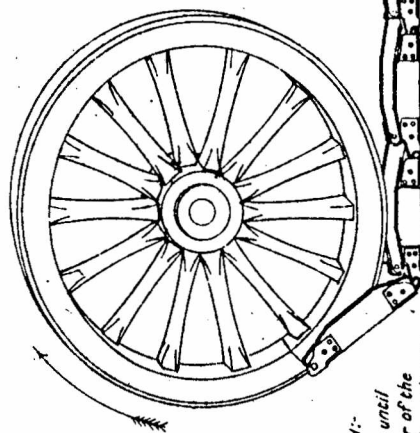

3rd OPERATION:-

Jack up the axle until the wheel is clear of the ground, bring Channels into position under the wheel, tie the end to the rim or to a spoke.

CARRIAGE, TRAVELLING, B. L. 6-INCH 26-CWT. HOWITZER.

METHOD OF ASSEMBLING GIRDLES.

3rd OPERATION (continued)

Revolve the wheel in direction of arrow until the rim is completely enveloped by the channels release cord and connect ends.

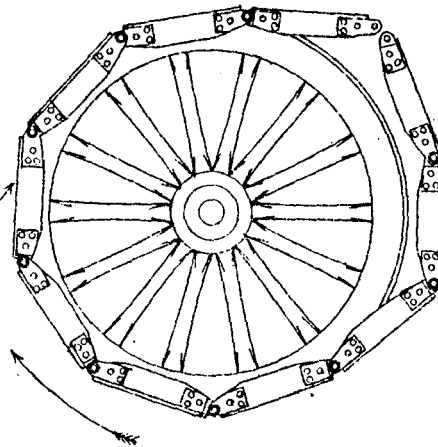

4th OPERATION

Attach one shoe on each side of Girdle to balance and continue in the same manner with the remaining shoes until Girdle is complete.

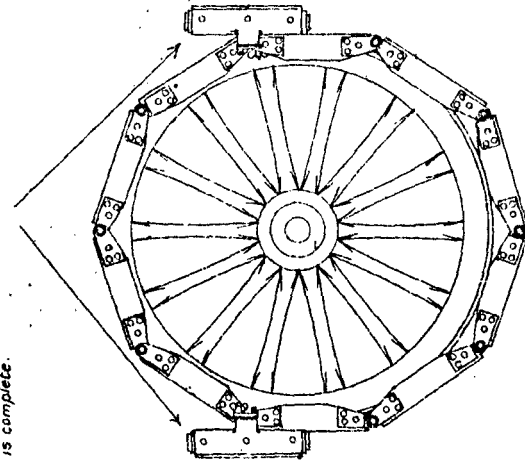

GIRDLE COMPLETE

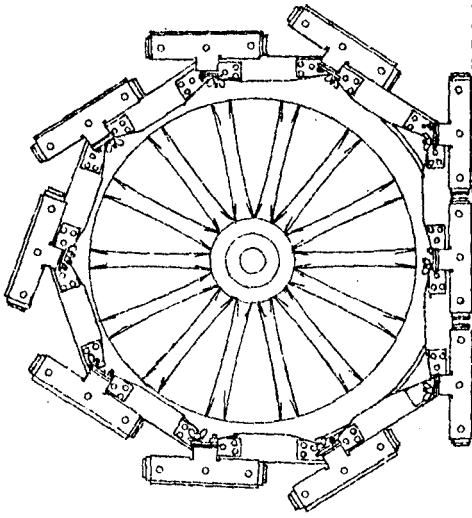

Application of Pinch Bar supplied with Girdle to Joint when connecting channels.

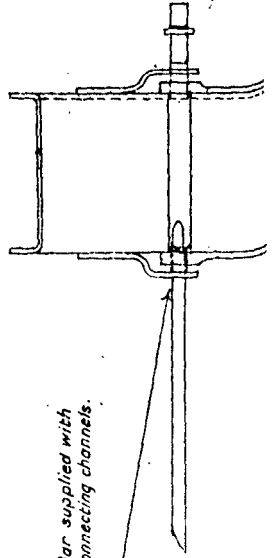

Application of Key supplied with Girdle to Wing Nuts.

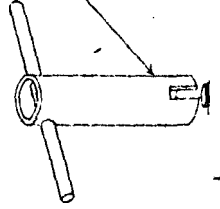

CARRIAGE, TRAVELLING, B.L. 6-INCH. 26-CWT. HOWITZER. MARK I | L.

ARRANGEMENT OF BUFFER & RECUPERATOR.

SCALE 1/8".

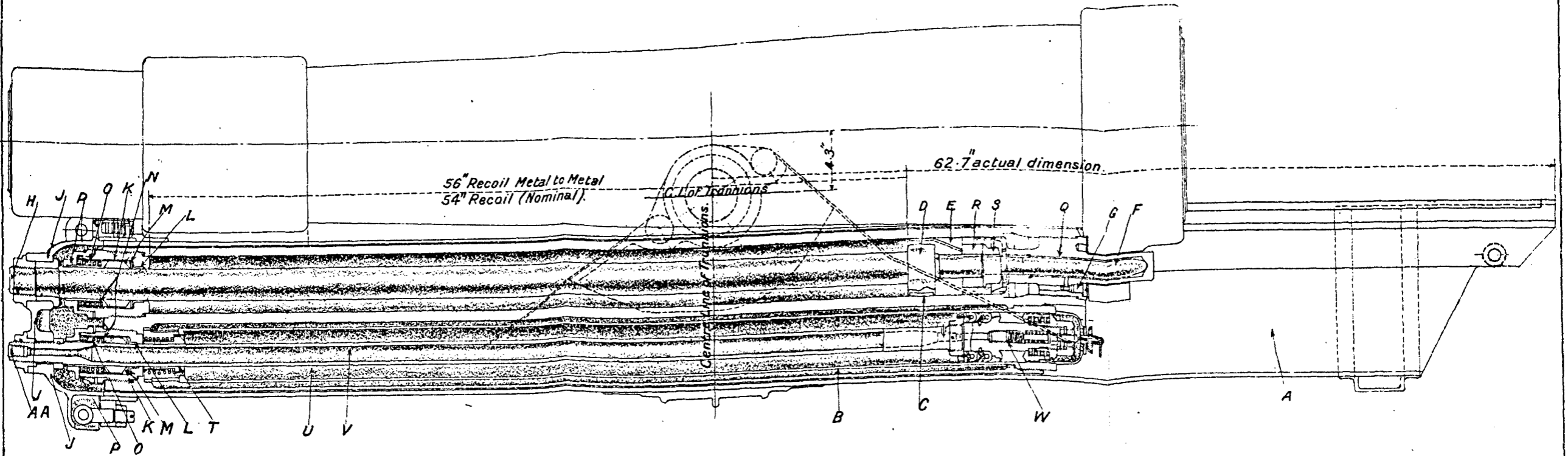

- A. Cradle.
- B. Buffer & Recuperator body.
- C. Buffer Cylinder.
- D. Piston.
- E. Rotating Valve.
- F. Control Plunger.
- G. Adjustable Valve.
- H. Piston Rod.
- J. Front Cap of Cradle.
- K. Stuffing Boxes.
- L. "L" Leathers or Rubbers
- M. Glands.

- N. Sleeves.
- O. Packing Springs.
- P. Caps securing packing.
- Q. Control Cylinder, Buffer.
- R. Thrust ring.
- S. Nut securing Valve.
- T. Throttle Valve, Recuperator.
- U. Recuperator liquid Cylinder.
- V. Recuperator Ram.
- W. Recuperator Ram head (for details See Plate XVI.)
- A.A. Plug closing adapter hole, Recuperator Ram.

CARRIAGE, TRAVELLING, B. L. 6-INCH 26-CWT. HOWITZER. MARK I.
 ENLARGED VIEW OF RECUPERATOR RAM HEAD. MARK III.

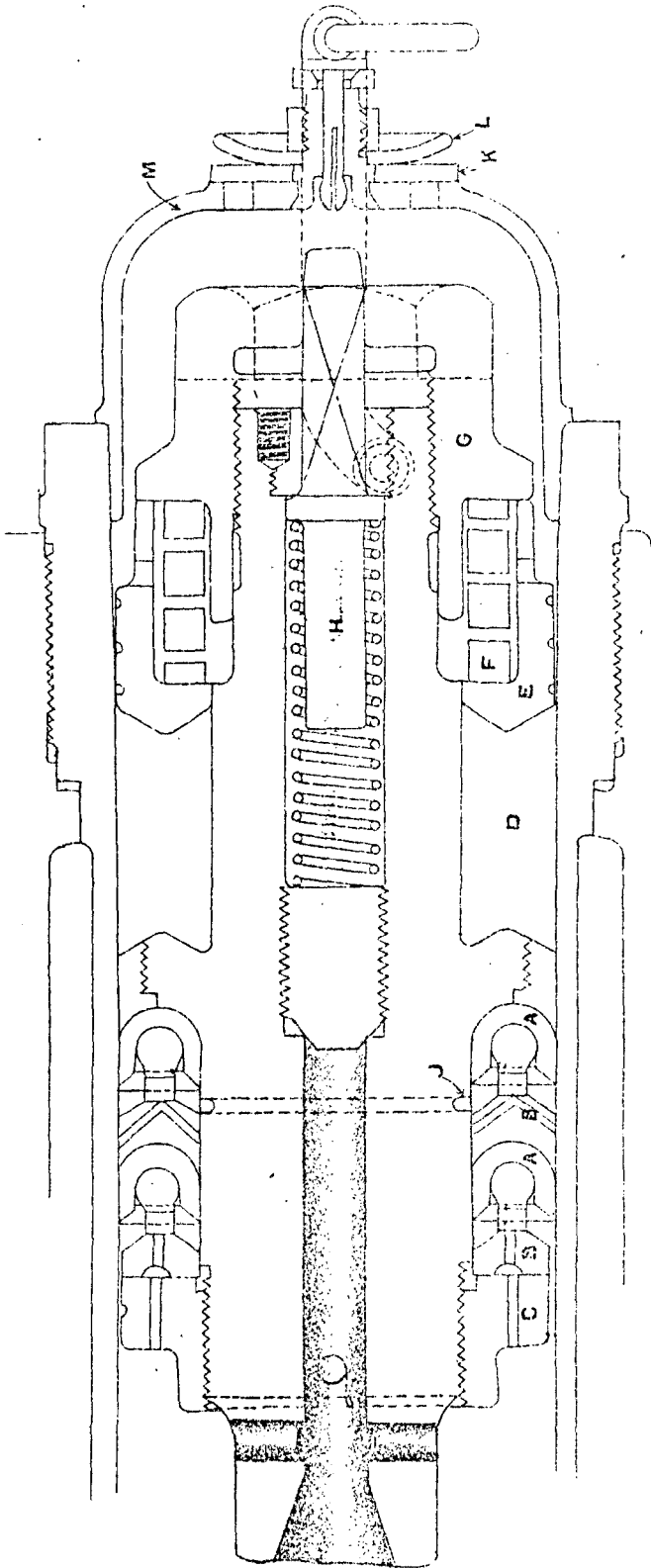

- A. U-rubbers.
- B. Rings supporting U-rubbers.
- C. Front securing nut.
- D. Compressed packing ring.
- K. Rubber washer.
- L. Guard plate.
- E. Ring supporting packing.
- F. Spiral spring.
- G. Rear securing nut.
- H. Spring plunger.
- J. Scoring ring (in halves)
- M. Dust cap.

CARRIAGE, TRAVELLING, B.L. 6-INCH 26-CWT. HOWITZER.
GENERAL ARRANGEMENT OF SNIFFING VALVE

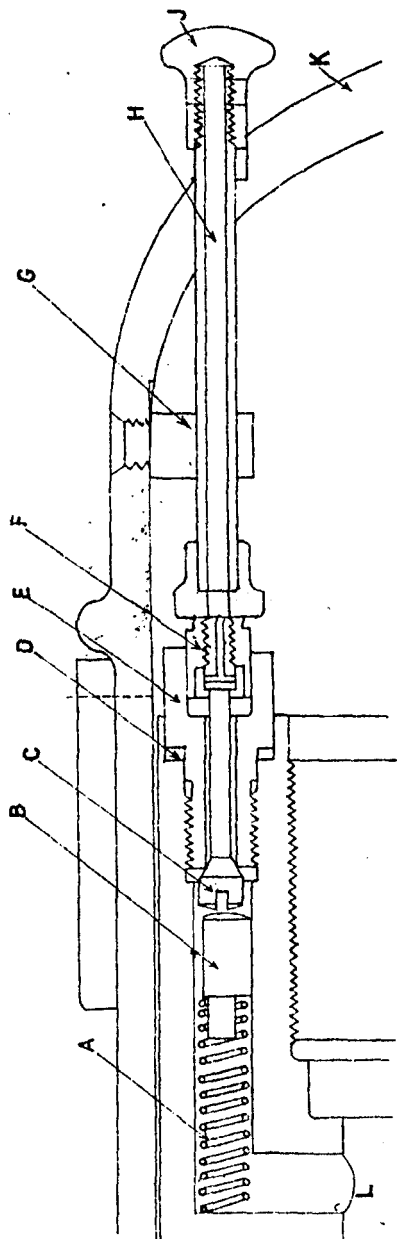

A. Spring.
 B. Plunger.
 C. Valve.

D. Plug.
 E. Washer.
 F. Guide, valve.

G. Guide, spindle.
 H. Spindle, operating.
 J. Knob.

K. Cradle cap.
 L. Buffer cylinder.

CARRIAGE, TRAVELLING, B.L. 6-INCH 26-CWT. HOWITZER.

SHOWING GRAVITY TANK MARK II AND ISOLATING VALVE.

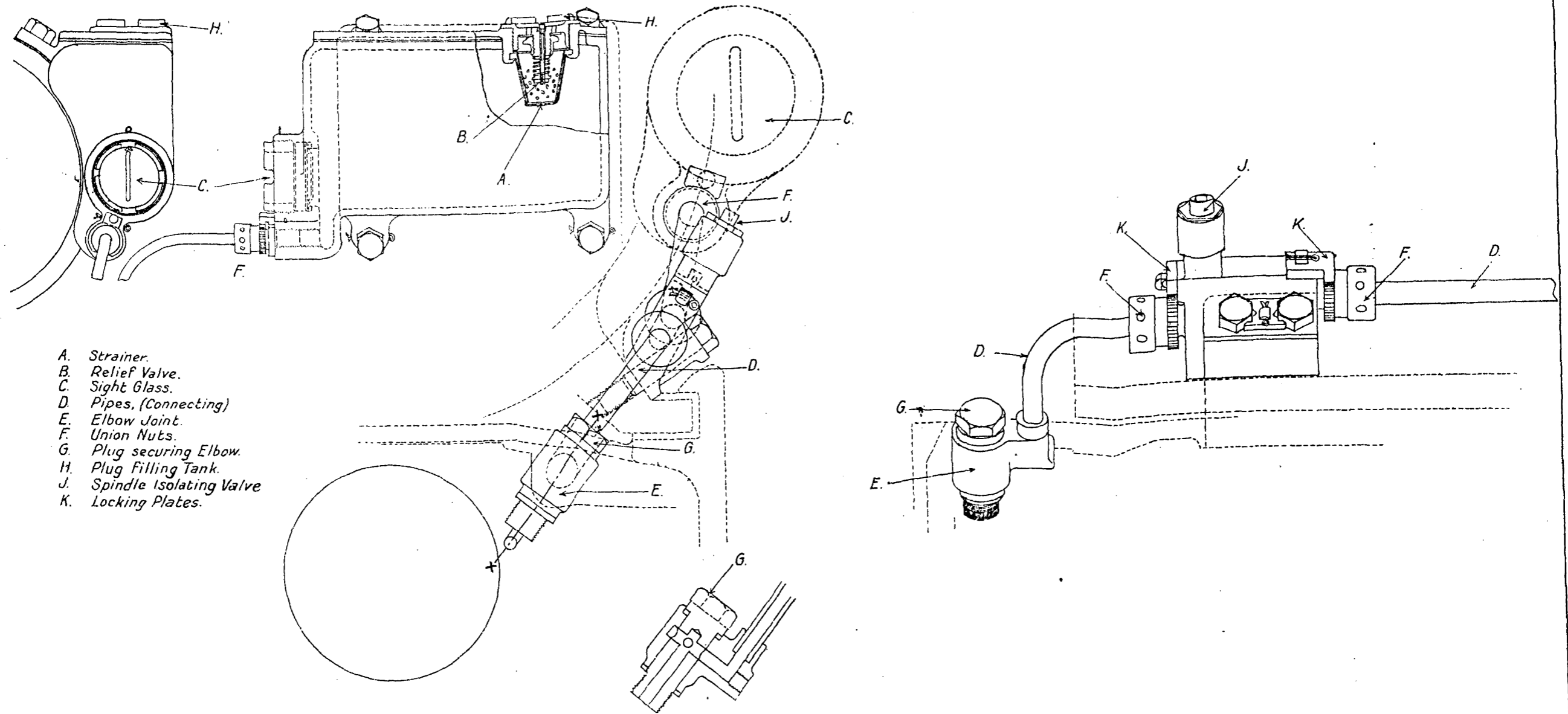

- A. Strainer.
- B. Relief Valve.
- C. Sight Glass.
- D. Pipes, (Connecting)
- E. Elbow Joint.
- F. Union Nuts.
- G. Plug securing Elbow.
- H. Plug Filling Tank.
- J. Spindle Isolating Valve
- K. Locking Plates.

SECTION ON X.X.

CARRIAGE, TRAVELLING. B. L. 6-INCH 26-CWT. HOWITZER MARK I.

ARRANGEMENT OF CUT-OFF GEAR.

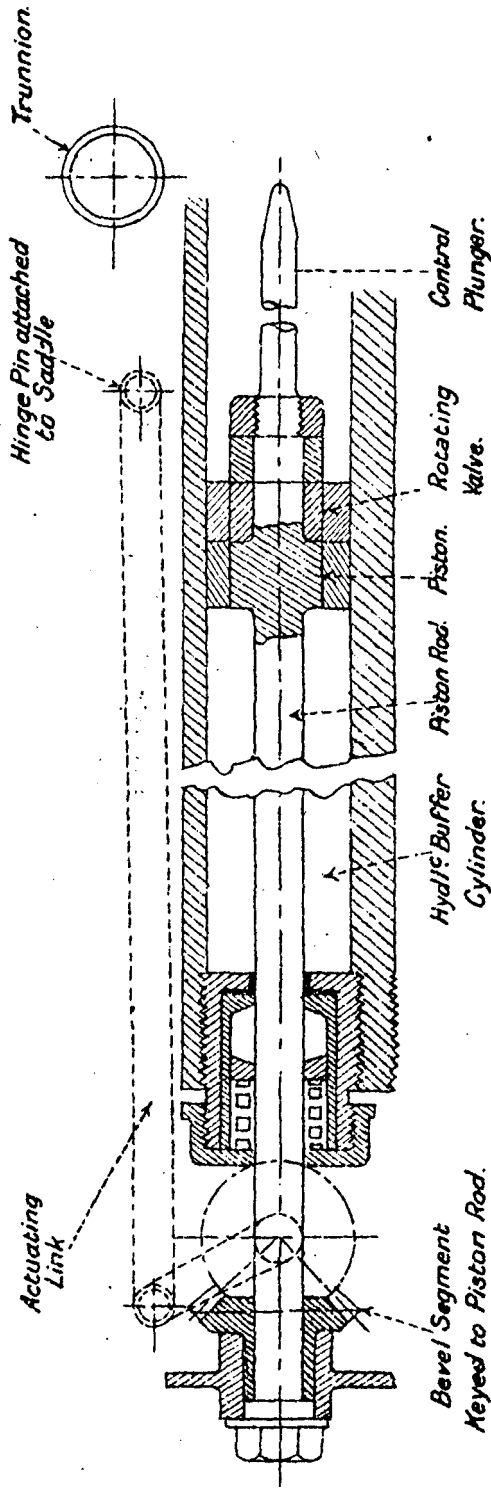

CARRIAGE, TRAVELLING, B. L. 6-INCH 26-CWT. HOWITZER.

GENERAL ARRANGEMENT OF CUT-OFF GEAR.

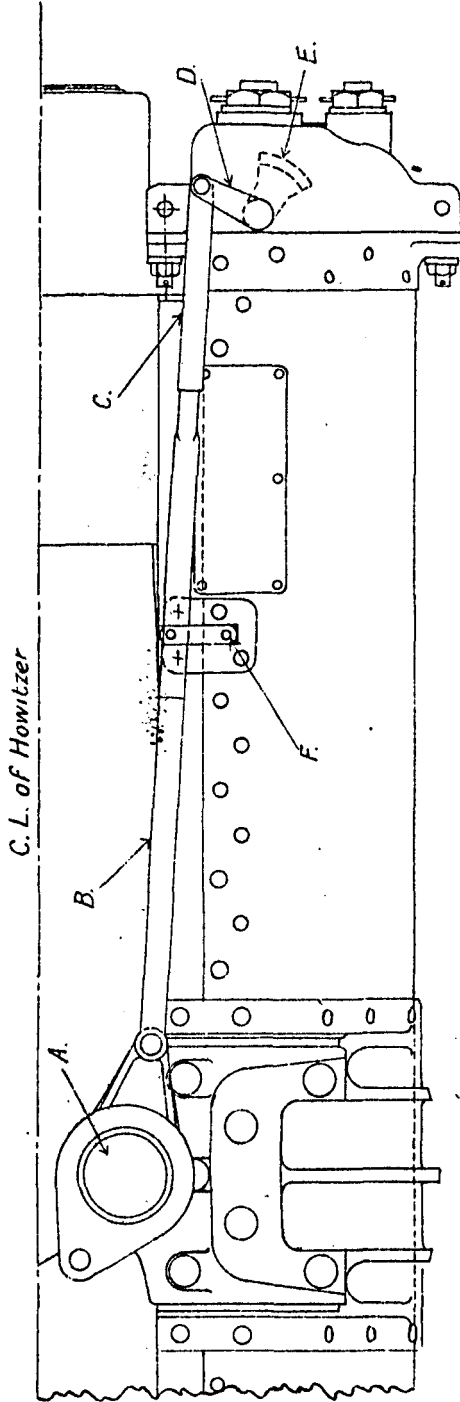

- A. Link, Trunnion, Mk. I.
- B. Rod, actuating, Mk. I
- C. Eye, Actuating Rod.
- D. Spindle Crank.
- E. Segment, Bevel Wheel.
- F. Guide, Actuating Rod.

CARRIAGE, TRAVELLING, B. L. 6-INCH 26-CWT. HOWITZER, MARK I.

BUFFER HYDRAULIC.

METHOD OF SETTING THE CUT-OFF GEAR.

TO ASCERTAIN THE POSITION OF CUT-OFF.

- PREPARATION** Remove howitzer and mechanism.
- I. (A) Sink the trail spade until the trail bears on the ground or raise the wheels of the carriage to counteract for the height of the spade; remove the loading block and set the elevation indicator to zero.
 - (B) Disconnect Cut-off Gear.
 - (C) Remove Cradle Cap.
 - (D) Run off Buffer Liquid.
 - (E) Remove stuffing-Box.
 - (F) Remove Rear Plug Buffer.
- II. Lash a stout plank to the top of the cradle and allow it to project about six feet in front.
- FIG. 1. Suspend the free end of the Piston Rod from the plank by means of a loop adjusted by wedges; this is necessary in order to prevent friction between the Rod and Cylinder, and thereby allows easy rotation of rod and valve.
- OPERATION I.** Pull out the Piston Rod until the dimension "A" reads $51.2 + 3.7 = 54.9$; this will place the valve in the same position, relative to the Buffer Cylinder, as at Full Recoil at Horizontal.
- FIG. 2. II. Rotate the Rod until the centre line of the Keys engaging with the Segment Bevel Wheel Piston Rod is horizontal. On examin^g of Piston and Valve it will be noticed that the Port is closed, or approximately so.
- FIG. 5. III. Rotate the Rod until the Port just closes; this can be observed by the use of an electric torch.
- FIG. 6. N.B. A cloth thrown over plank and rod to obscure all side-light, similar to a camera cloth will greatly assist.
- IV. When the Port is closed, the pronged sleeve should be inserted over the Piston Rod to engage with the Keyways in the "Segment, Bevel Wheel, Piston Rod" as in Fig. 1.
 - V. The Clinometer should then be used over the pronged extensions of the sleeve and the angular reading noted.
 - VI. The reading should be verified and recorded.

TO REPRODUCE THE POSITION OF CUT-OFF.

- PREPARATION I.** Assemble howitzer and cradle in the ordinary way.
- II. (A) Remove "Nut, securing Piston Rod" (B) Disconnect the "Pin, Connecting", from the Spindle crank, Cut-off Gear. (c) See that the elevation indicator reads zero.
 - III. Insert the pronged sleeve over the Piston Rod.
 - IV. Set the Clinometer at the required angle.
- OPERATION I.** Lay the Clinometer on the prongs of the sleeve, and by means of the Spindle Crank, rotate the Piston Rod until the spirit level centralises. The Piston Rod should now be in the angular position to give the desired Cut-off.
- FIG. 7. II. Bring the howitzer to maximum depression.
- III. Adjust the "Rod, Actuating, Cut-off Gear" until the "Pin, Connecting" will enter the holes in the end of the Rod and the Spindle Crank without any effort.
 - IV. Verify that this adjustment of the Cut-off Gear will not alter the setting of the Valve. This can be done by elevating and fully depressing and finally levelling the cradle and then taking the reading of the angular position of the Piston Rod.
 - V. Adjustment should be made accordingly for all differences above 0.25'.
- FINAL.** When the desired position has been reached, the length of "Rod, Actuating, Cut-off Gear" should be fixed by inserting a Split Pin and securing. After removing the pronged sleeve and reassembling the "Nut, Piston Rod", the carriage will be ready for action. Under normal conditions the dimension "B" in Fig. 7. will average about 45"

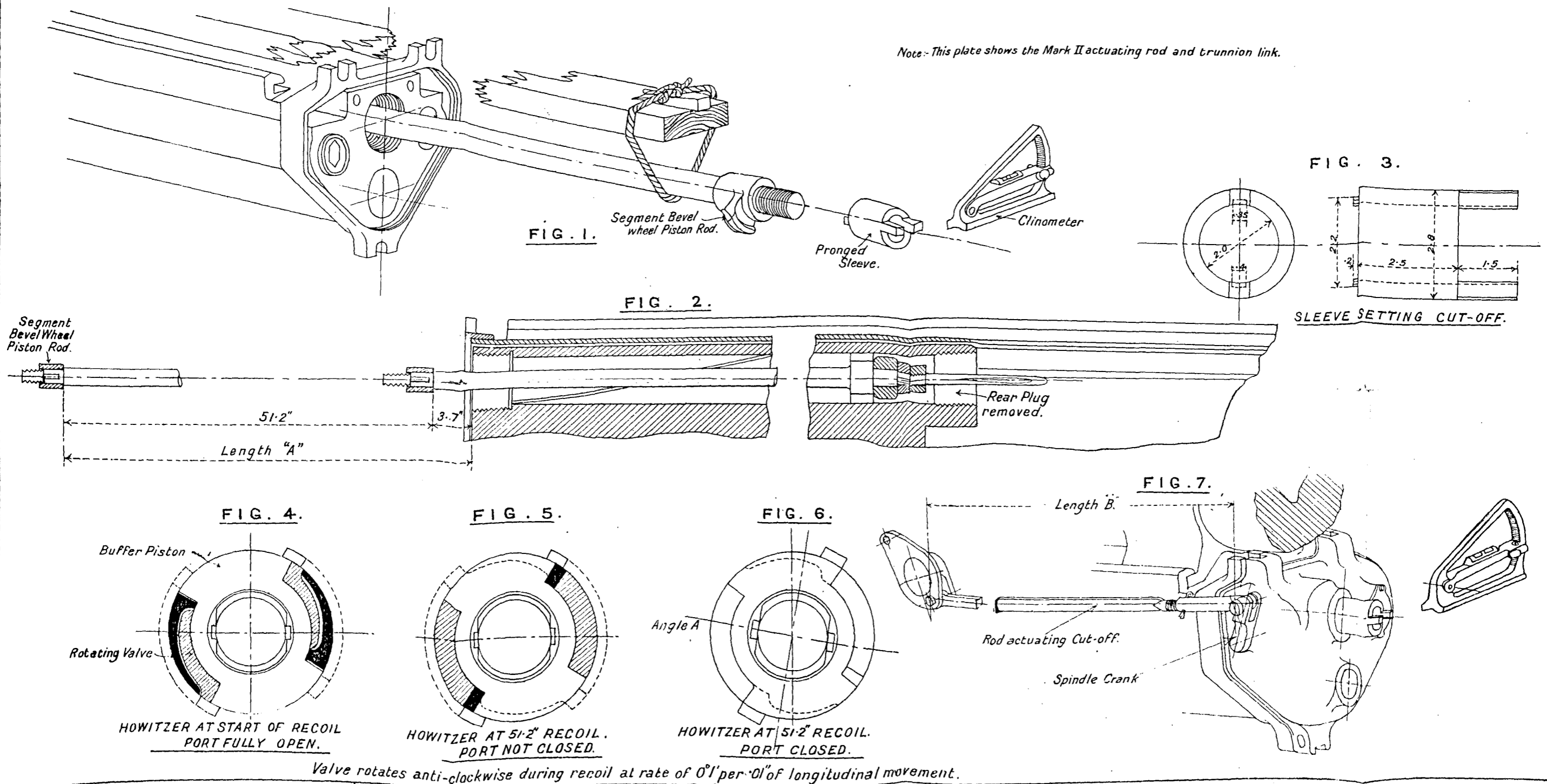

CARRIAGE. TRAVELLING, B.L. 6 INCH 26 CWT. HOWITZER.

— SHOWING PRESSURE GAUGE IN POSITION. —

TYPICAL.

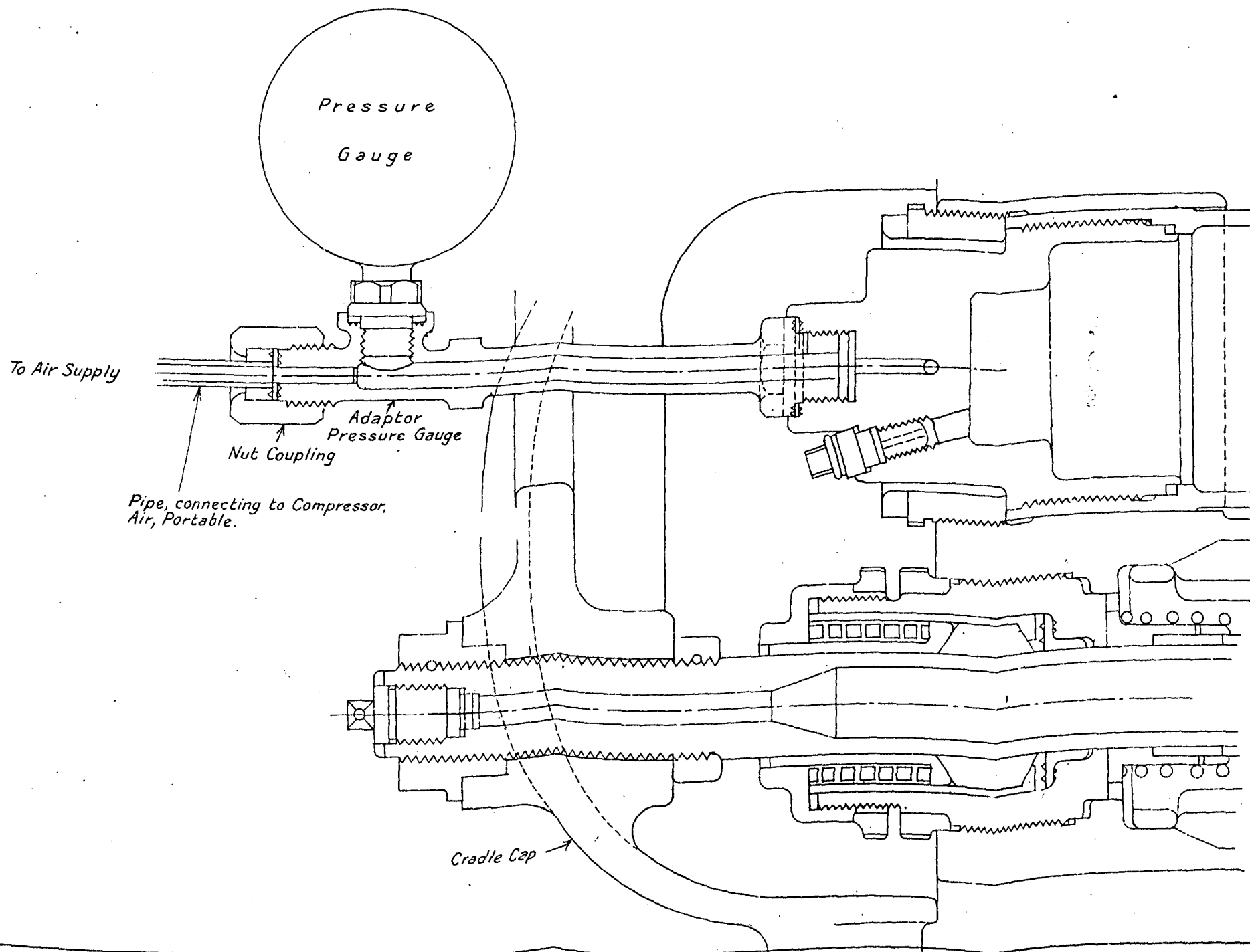

CARRIAGE, TRAVELLING, B.L. 6-INCH 26-CWT. HOWITZER, MARK I.
ARRANGEMENT OF ELEVATING, TRAVERSING,
QUICK LOADING & SIGHT OPERATING GEARS.

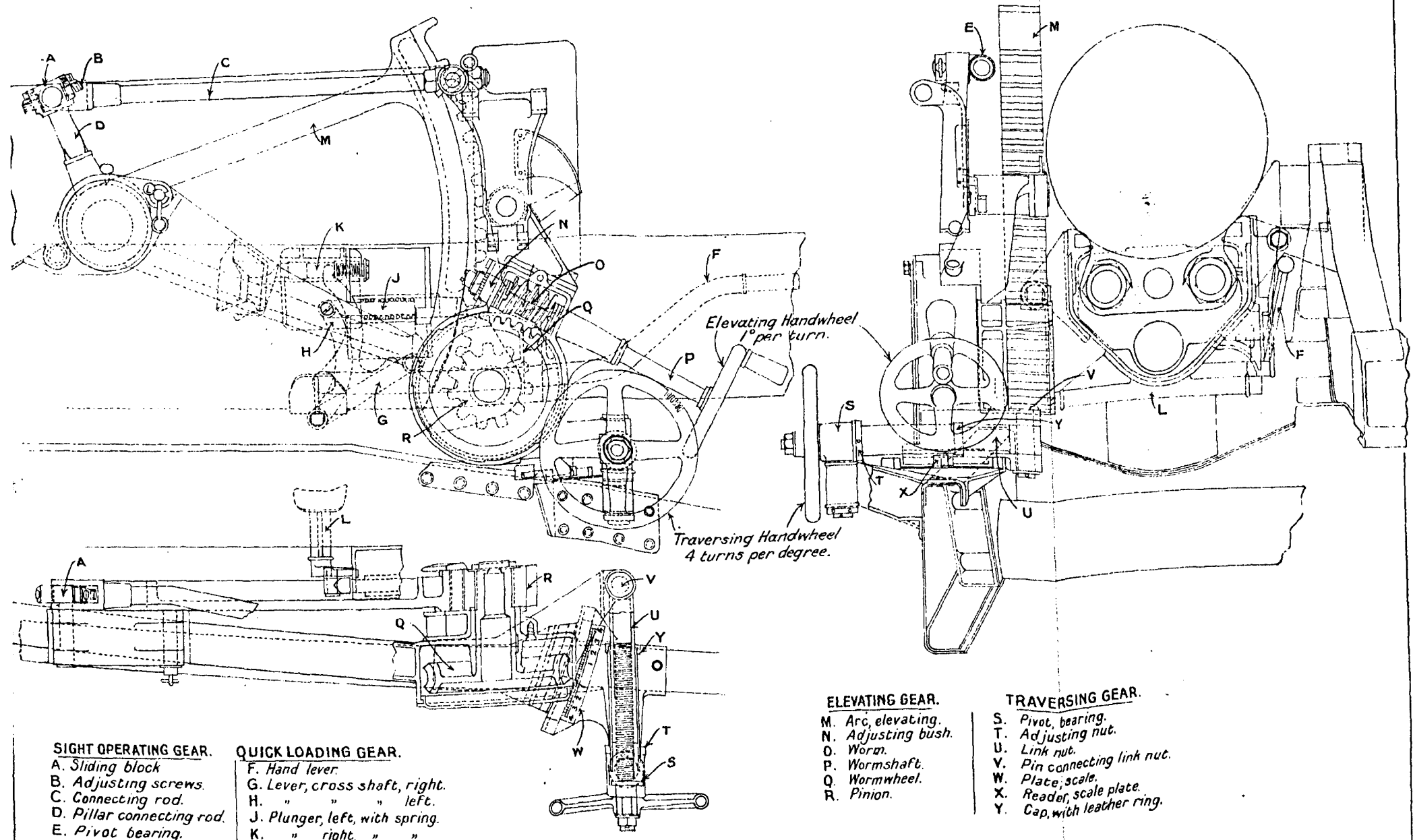

SIGHT OPERATING GEAR.

- A. Sliding block
- B. Adjusting screws.
- C. Connecting rod.
- D. Pillar connecting rod.
- E. Pivot bearing.

QUICK LOADING GEAR.

- F. Hand lever.
- G. Lever, cross shaft, right.
- H. " " " left.
- J. Plunger, left, with spring.
- K. " right, " "
- L. Cross shaft.

ELEVATING GEAR.

- M. Arc, elevating.
- N. Adjusting bush.
- O. Worm.
- P. Wormshaft.
- Q. Wormwheel.
- R. Pinion.

TRAVERSING GEAR.

- S. Pivot, bearing.
- T. Adjusting nut.
- U. Link nut.
- V. Pin connecting link nut.
- W. Plate, scale.
- X. Reader, scale plate.
- Y. Cap, with leather ring.

SIGHT, ROCKING-BAR, CARRIAGE, TRAVELLING, B. L. 6" 26 CWT HOWITZER.
GENERAL ARRANGEMENT, WITH SIGHT CLINOMETER, DIAL SIGHT.
Nº 7 AND CARRIER Nº 5.
 SCALE = 1/3.

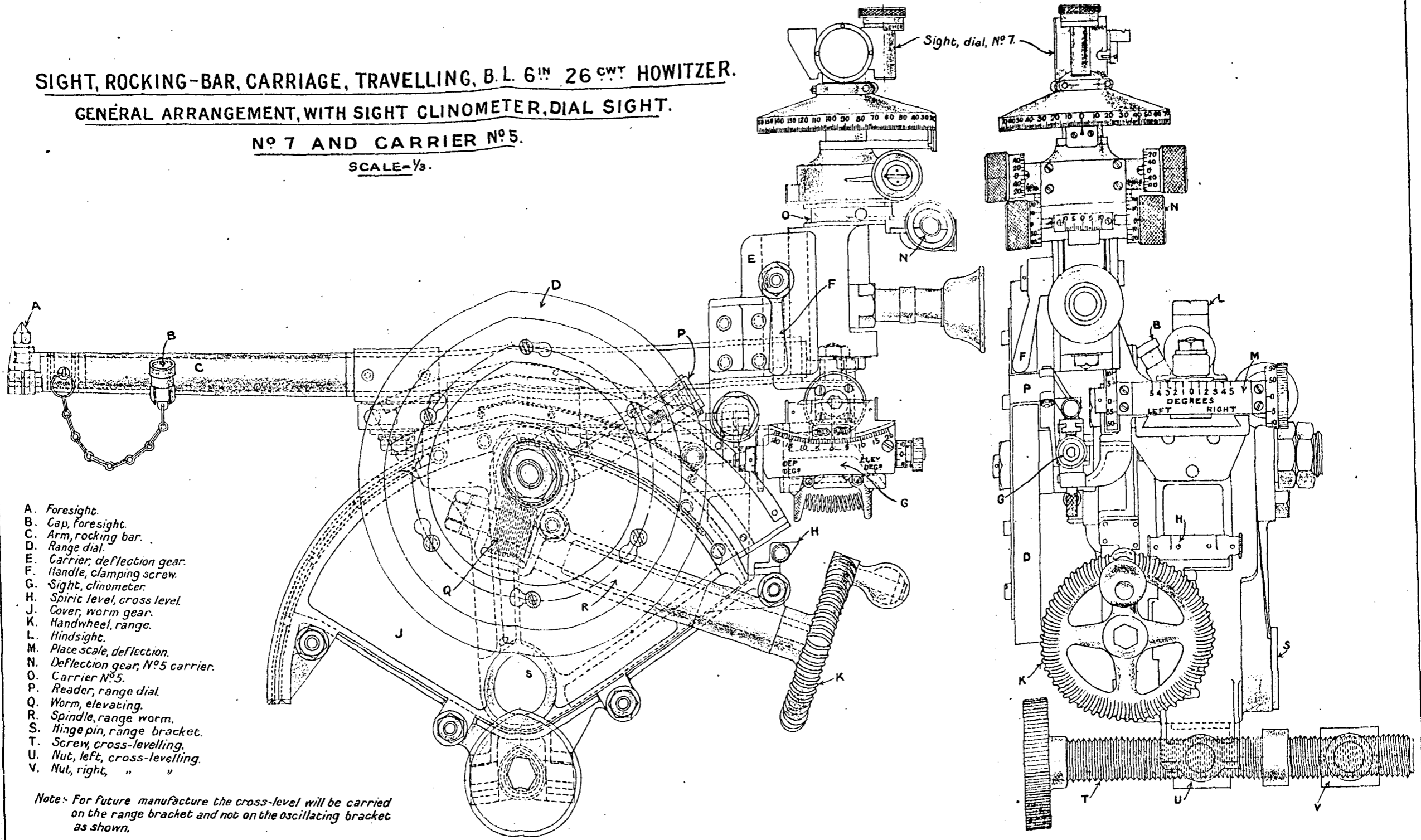

- A. Foresight.
- B. Cap, foresight.
- C. Arm, rocking bar.
- D. Range dial.
- E. Carrier, deflection gear.
- F. Handle, clamping screw.
- G. Sight, clinometer.
- H. Spirit level, cross level.
- J. Cover, worm gear.
- K. Handwheel, range.
- L. Hindsight.
- M. Plate scale, deflection.
- N. Deflection gear, Nº 5 carrier.
- O. Carrier Nº 5.
- P. Reader, range dial.
- Q. Worm, elevating.
- R. Spindle, range worm.
- S. Hinge pin, range bracket.
- T. Screw, cross-levelling.
- U. Nut, left, cross-levelling.
- V. Nut, right, " "

Note:- For future manufacture the cross-level will be carried on the range bracket and not on the oscillating bracket as shown.

SIGHT, DIAL, N^o 7, MARK III.

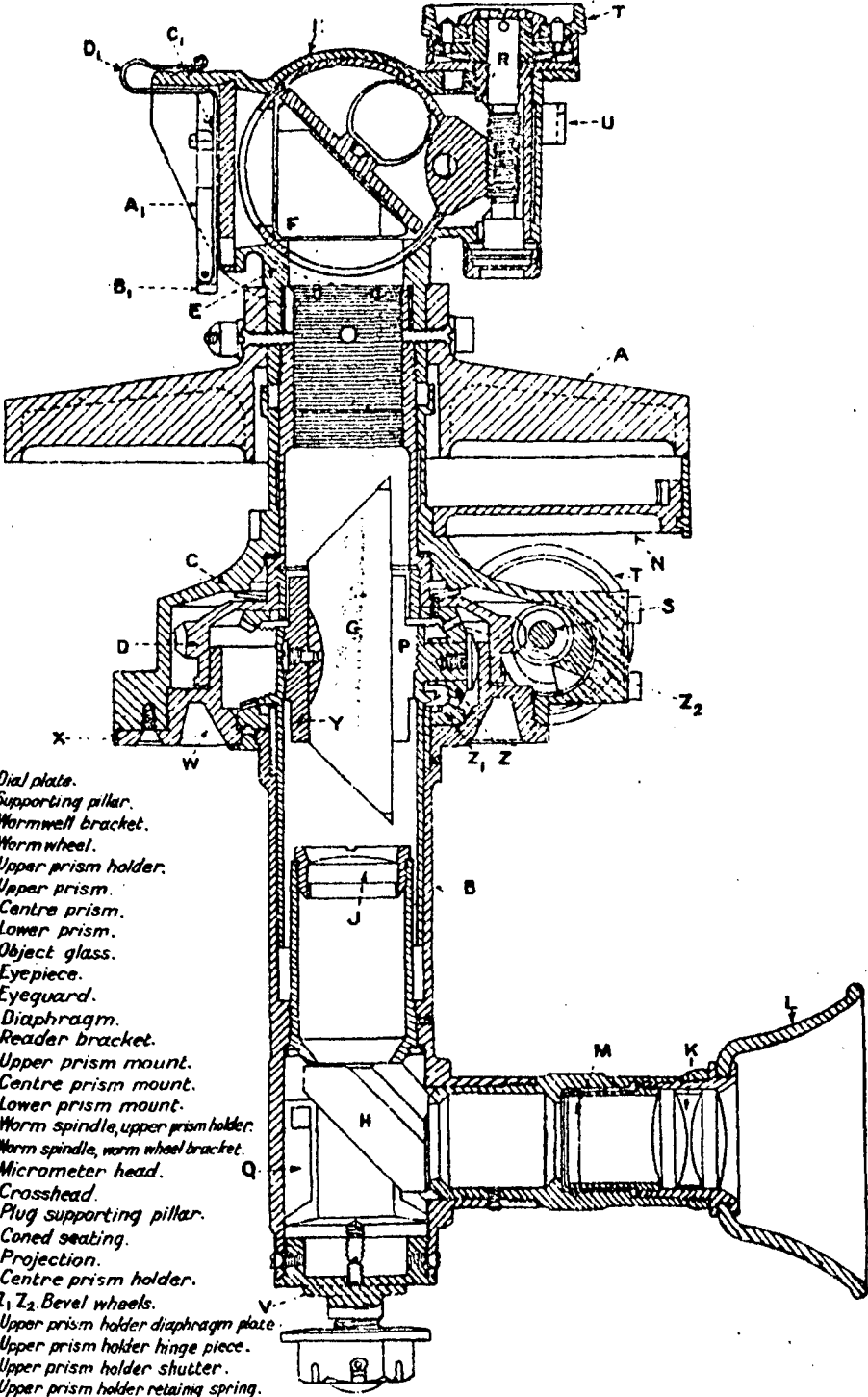

- A. Dial plate.
- B. Supporting pillar.
- C. Wormwell bracket.
- D. Wormwheel.
- E. Upper prism holder.
- F. Upper prism.
- G. Centre prism.
- H. Lower prism.
- J. Object glass.
- K. Eyepiece.
- L. Eyeguard.
- M. Diaphragm.
- N. Reader bracket.
- O. Upper prism mount.
- P. Centre prism mount.
- Q. Lower prism mount.
- R. Worm spindle, upper prism holder.
- S. Worm spindle, worm wheel bracket.
- T. Micrometer head.
- U. Crosshead.
- V. Plug supporting pillar.
- W. Coned seating.
- X. Projection.
- Y. Centre prism holder.
- Z, Z₁, Z₂. Bevel wheels.
- A₁. Upper prism holder diaphragm plate.
- B. Upper prism holder hinge piece.
- C. Upper prism holder shutter.
- D. Upper prism holder retaining spring.

SIGHT, DIAL. N° 7. MARK III.
SHOWING MARKING FOR FUTURE MANUFACTURE

SCALE $\frac{2}{3}$

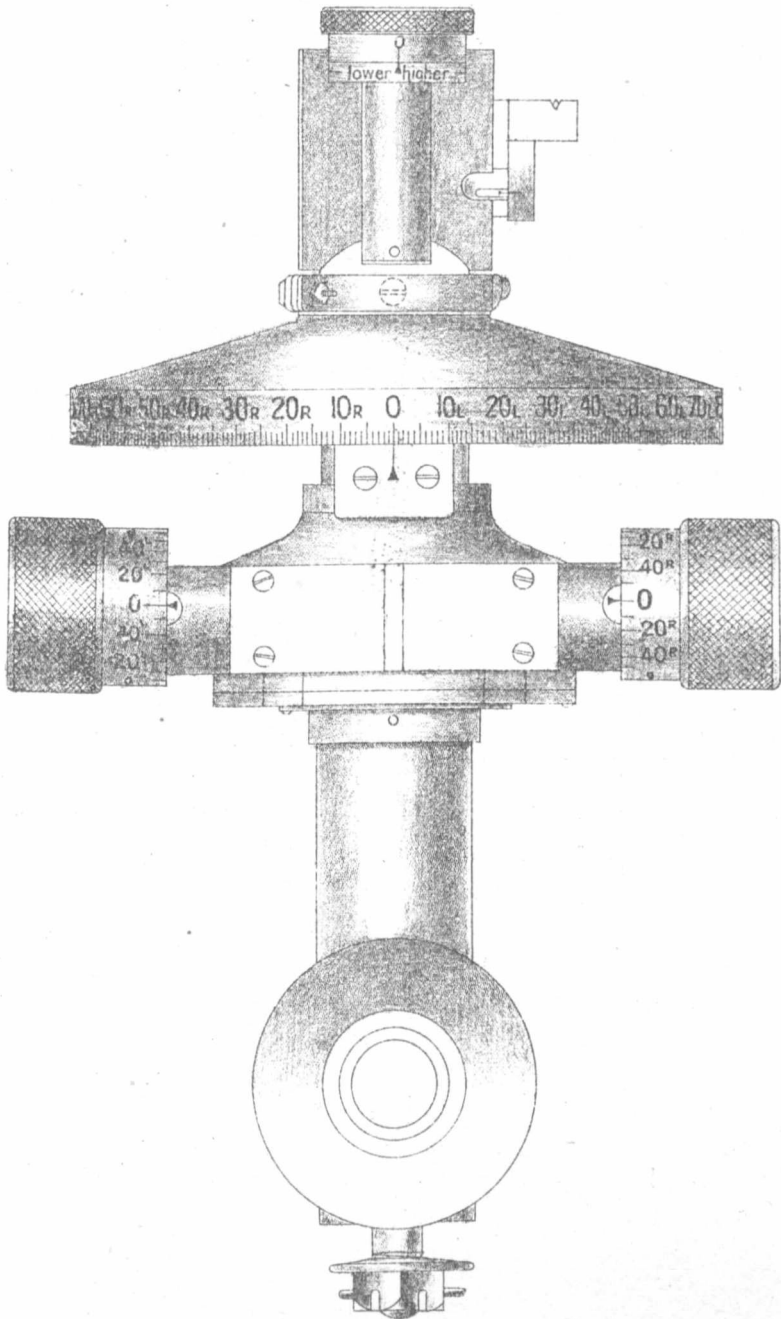

SIGHT, DIAL, N° 1, MARK II.

SCALE - $\frac{1}{3}$.

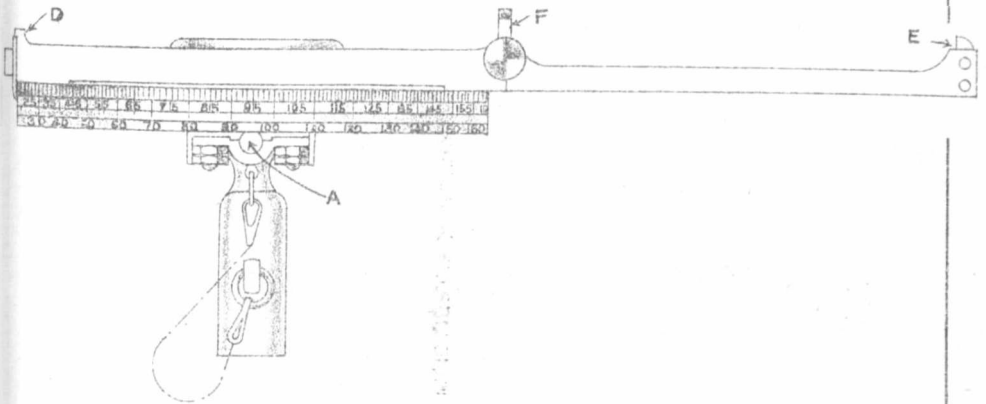

SIDE ELEVATION.

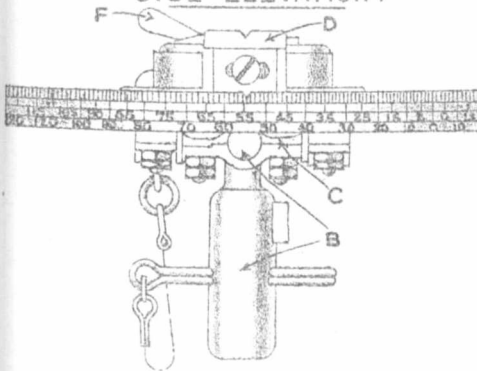

REAR ELEVATION.

- | | |
|---------------------|------------------|
| A. Cross head. | D. Hindsight. |
| B. Pin, cross head. | E. Foresight. |
| C. Cap, cross head. | F. Clamping nut. |

CARRIAGE, TRAVELLING, B. L. 6-IN. 26-CWT. HOWITZER.

— TARGET TESTING SIGHTS. —

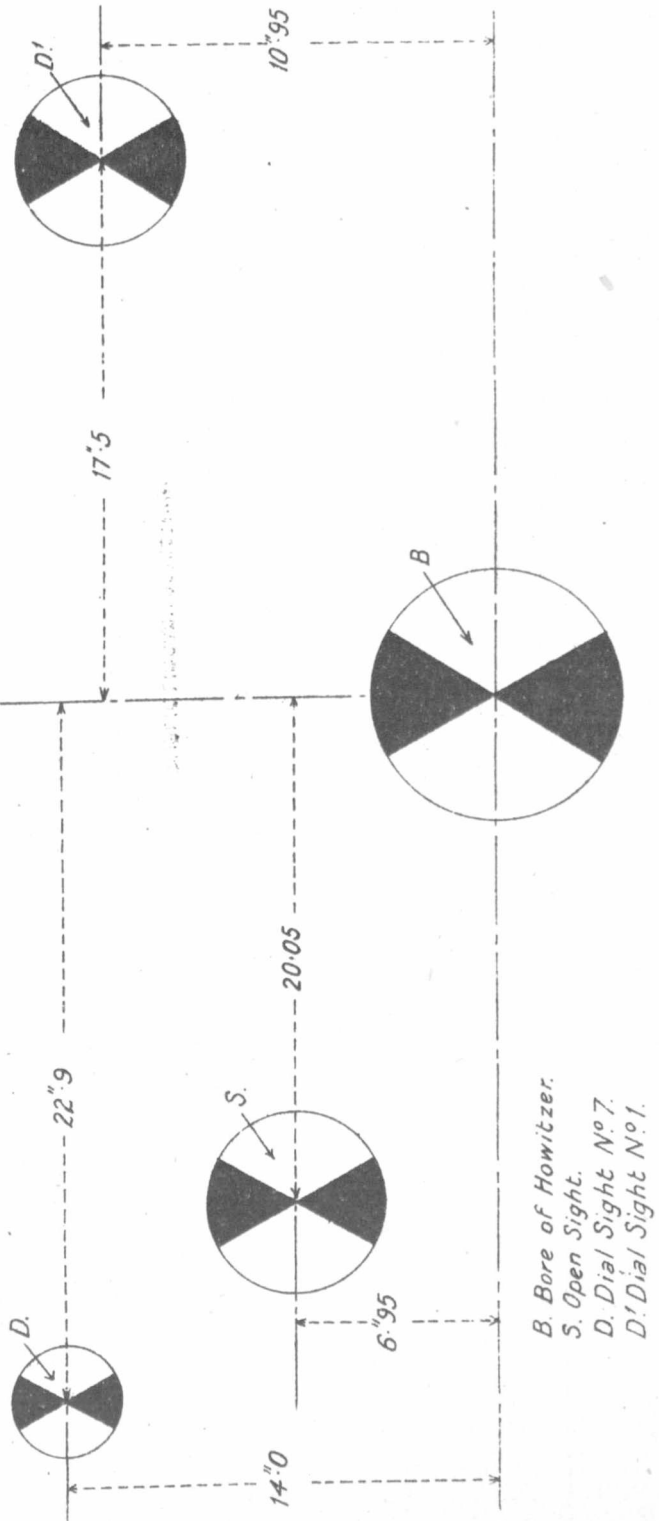

LIMBER, B.L. 6-INCH 26-CWT. HOWITZER, MARK I.

SCALE = 1/10.

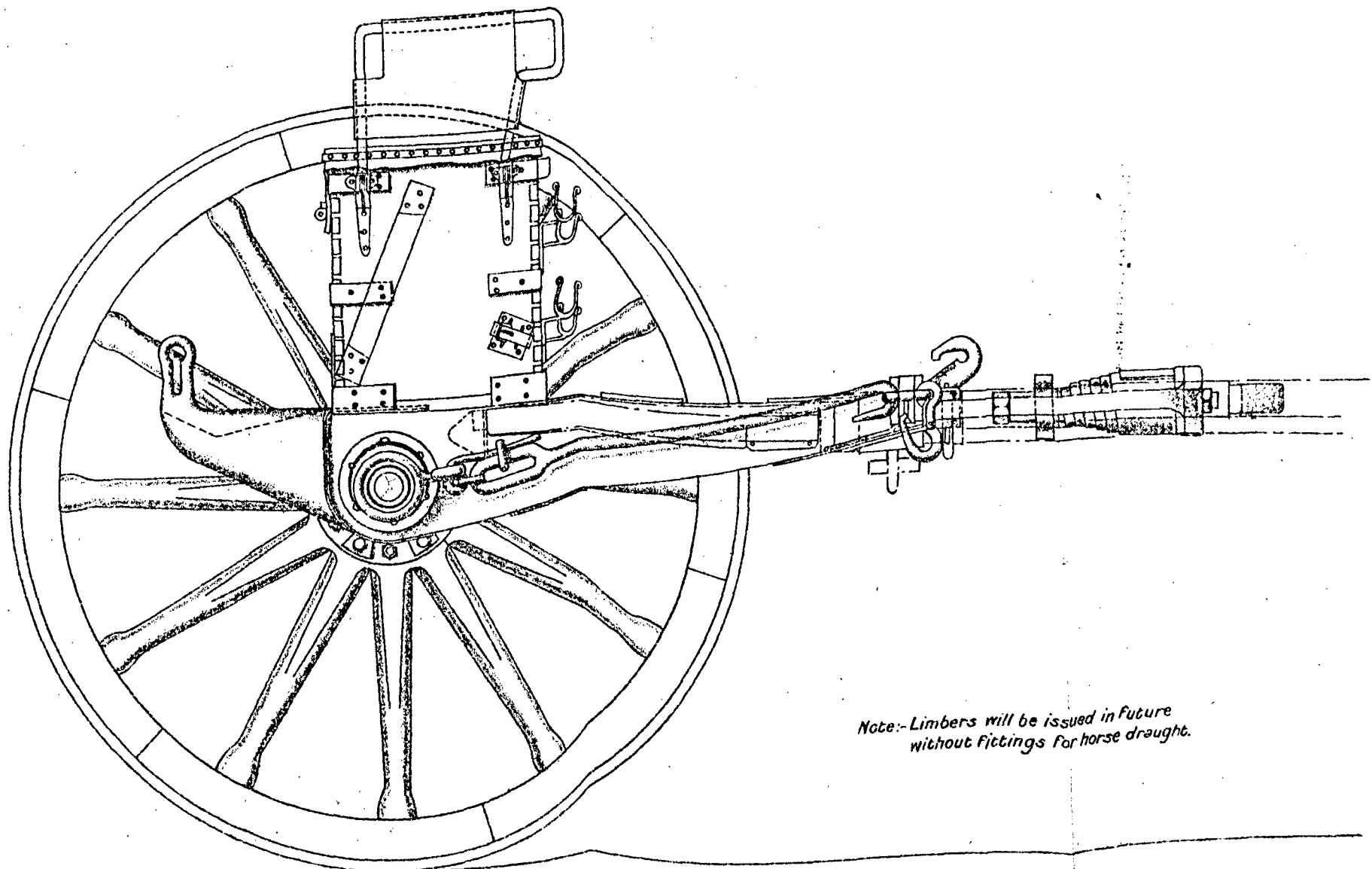

*Note:-Limbers will be issued in future
without fittings for horse draught.*

SIDE ELEVATION

PUBLIC LIBRARY OF VICTORIA

COMPRESSOR, AIR, PORTABLE, MARK I.

VIEW SHOWING N°2 VERTICAL TWO - STAGE AIR - PUMP MOUNTED .

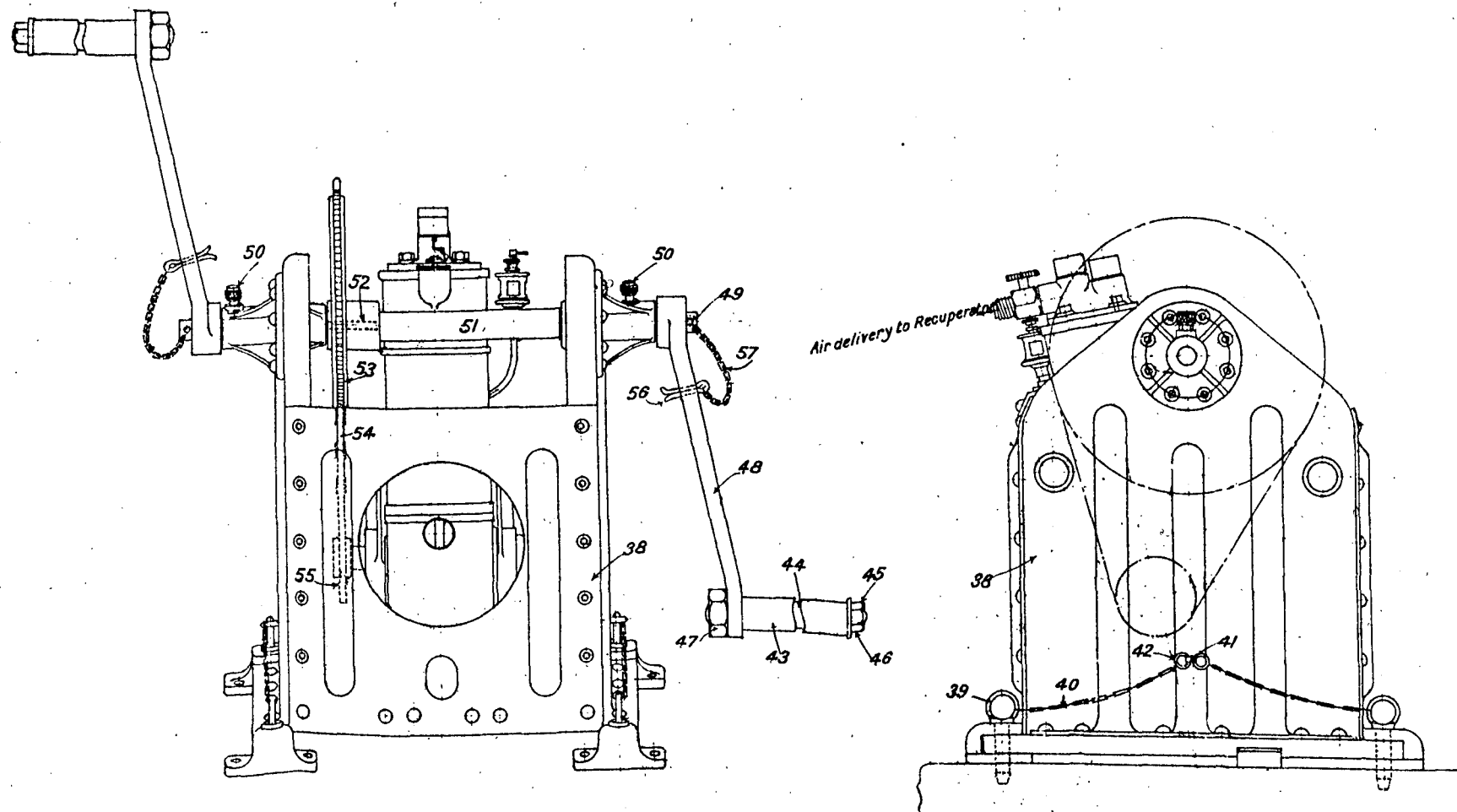

Note:- For replacement purposes the various components should be demanded under the following nomenclature:-

	Code Word.		Code Word.		Code Word.
38. Housing.	Housing.	45. Handle Lock Nut	Houlock.	52. Key	Houkey.
39. Dowel Pin.	Houdowel.	46. Lock Nut Washer	Houcap.	53. Chain Wheel	Houwheel.
40. " " Chain	Houswire.	47. Handle Nut	Hounut.	54. Chain	Houchain.
41. Eye Bolt	Houeye.	48. Crank	Houcrank.	55. Sprocket Wheel	Housprock.
42. " " Ring	Houring.	49. Split Pin	Houpin.	56. Cotter	Houcct.
43. Brass Tube for Handle	Houtube.	50. Lubricator	Houlub.	57. Cotter Chain	Houlink.
44. Handle	Houhand.	51. Shaft	Houspind.		

COMPRESSOR, AIR, PORTABLE, MARK I.

VIEW SHOWING N°2 VERTICAL TWO-STAGE AIR-PUMP.

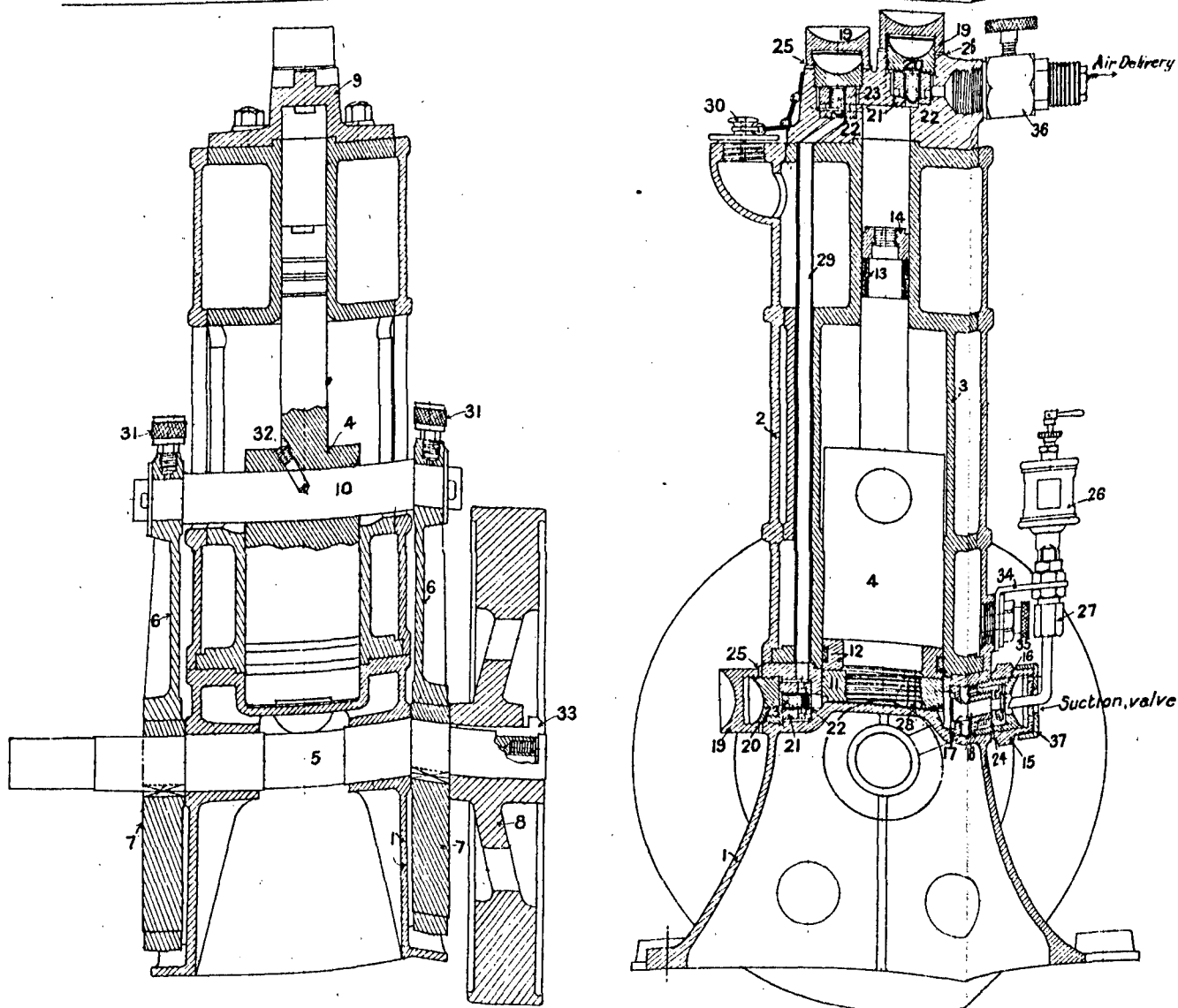

NOTE:- For replacement purposes the various components should be demanded under the following nomenclature:-

<table border="0"> <tr><td>1</td><td>Pedestal</td><td>Code Word</td><td>Vicpedest</td></tr> <tr><td>2</td><td>Cylinder</td><td>Code Word</td><td>Vicyl</td></tr> <tr><td>3</td><td>Liner</td><td>Code Word</td><td>Vicliner</td></tr> <tr><td>4</td><td>Piston</td><td>Code Word</td><td>Viciston</td></tr> <tr><td>5</td><td>Crankshaft</td><td>Code Word</td><td>Vichaft</td></tr> <tr><td>6</td><td>Eccentric Strap</td><td>Code Word</td><td>Vicentric</td></tr> <tr><td>7</td><td>" Sheave</td><td>Code Word</td><td>Vicheave</td></tr> <tr><td>8</td><td>Flywheel</td><td>Code Word</td><td>Vicweel</td></tr> <tr><td>9</td><td>Cylinder Cover</td><td>Code Word</td><td>Vicover</td></tr> </table>	1	Pedestal	Code Word	Vicpedest	2	Cylinder	Code Word	Vicyl	3	Liner	Code Word	Vicliner	4	Piston	Code Word	Viciston	5	Crankshaft	Code Word	Vichaft	6	Eccentric Strap	Code Word	Vicentric	7	" Sheave	Code Word	Vicheave	8	Flywheel	Code Word	Vicweel	9	Cylinder Cover	Code Word	Vicover	<table border="0"> <tr><td>10</td><td>Gudgeon Pin</td><td>Code Word</td><td>Vicgugpin</td></tr> <tr><td>11</td><td>L.P. Junk Plate</td><td>Code Word</td><td>Vicplate</td></tr> <tr><td>12</td><td>L.P. Packing Rings</td><td>Code Word</td><td>Viclowpack</td></tr> <tr><td>13</td><td>H.P. " "</td><td>Code Word</td><td>Vichipack</td></tr> <tr><td>14</td><td>H. P. Junk Ring</td><td>Code Word</td><td>Vichijunk</td></tr> <tr><td>15</td><td>Suction Valve Cap</td><td>Code Word</td><td>Vicscap</td></tr> <tr><td>16</td><td>" " Plug</td><td>Code Word</td><td>Vicsplug</td></tr> <tr><td>17</td><td>" " Seat</td><td>Code Word</td><td>Vicseat</td></tr> <tr><td>18</td><td>" Valve</td><td>Code Word</td><td>Vicsalve</td></tr> </table>	10	Gudgeon Pin	Code Word	Vicgugpin	11	L.P. Junk Plate	Code Word	Vicplate	12	L.P. Packing Rings	Code Word	Viclowpack	13	H.P. " "	Code Word	Vichipack	14	H. P. Junk Ring	Code Word	Vichijunk	15	Suction Valve Cap	Code Word	Vicscap	16	" " Plug	Code Word	Vicsplug	17	" " Seat	Code Word	Vicseat	18	" Valve	Code Word	Vicsalve	<table border="0"> <tr><td>19</td><td>Delivery Valve Cap</td><td>Code Word</td><td>Vicdelcap</td></tr> <tr><td>20</td><td>" " Plug</td><td>Code Word</td><td>Vicdelplug</td></tr> <tr><td>21</td><td>" " Seat</td><td>Code Word</td><td>Vicdelseat</td></tr> <tr><td>22</td><td>" Valve</td><td>Code Word</td><td>Vicdeval</td></tr> <tr><td>23</td><td>" " Spring</td><td>Code Word</td><td>Vicdepring</td></tr> <tr><td>24</td><td>Suction Valve Spring</td><td>Code Word</td><td>Vicsupring</td></tr> <tr><td>25</td><td>Washer</td><td>Code Word</td><td>Vicwasher</td></tr> <tr><td>26</td><td>Drip Lubricator †</td><td>Code Word</td><td>Viclubr</td></tr> <tr><td>27</td><td>" Union & Pipe</td><td>Code Word</td><td>Viclupipe</td></tr> </table>	19	Delivery Valve Cap	Code Word	Vicdelcap	20	" " Plug	Code Word	Vicdelplug	21	" " Seat	Code Word	Vicdelseat	22	" Valve	Code Word	Vicdeval	23	" " Spring	Code Word	Vicdepring	24	Suction Valve Spring	Code Word	Vicsupring	25	Washer	Code Word	Vicwasher	26	Drip Lubricator †	Code Word	Viclubr	27	" Union & Pipe	Code Word	Viclupipe	<table border="0"> <tr><td>28</td><td>Locking Screw</td><td>Code Word</td><td>Vicscrew</td></tr> <tr><td>29</td><td>Cooling Pipe</td><td>Code Word</td><td>Viccooler</td></tr> <tr><td>30</td><td>Water Inlet Plug</td><td>Code Word</td><td>Vicfiller</td></tr> <tr><td>31</td><td>Stauffer Lubricator</td><td>Code Word</td><td>Vicstaffer</td></tr> <tr><td>32</td><td>Gudgeon Locking Pin</td><td>Code Word</td><td>Viclokpin</td></tr> <tr><td>33</td><td>Gib Key</td><td>Code Word</td><td>Vicgibkey</td></tr> <tr><td>34</td><td>Lubricator Bracket</td><td>Code Word</td><td>Viclubrak</td></tr> <tr><td>35</td><td>Water Outlet Plug</td><td>Code Word</td><td>Vicwatlet</td></tr> <tr><td>36</td><td>Bye-pass Valve</td><td>Code Word</td><td>Vicbypass</td></tr> <tr><td>37</td><td>Suction Cover †</td><td>Code Word</td><td>Vicsuov</td></tr> </table>	28	Locking Screw	Code Word	Vicscrew	29	Cooling Pipe	Code Word	Viccooler	30	Water Inlet Plug	Code Word	Vicfiller	31	Stauffer Lubricator	Code Word	Vicstaffer	32	Gudgeon Locking Pin	Code Word	Viclokpin	33	Gib Key	Code Word	Vicgibkey	34	Lubricator Bracket	Code Word	Viclubrak	35	Water Outlet Plug	Code Word	Vicwatlet	36	Bye-pass Valve	Code Word	Vicbypass	37	Suction Cover †	Code Word	Vicsuov
1	Pedestal	Code Word	Vicpedest																																																																																																																																																				
2	Cylinder	Code Word	Vicyl																																																																																																																																																				
3	Liner	Code Word	Vicliner																																																																																																																																																				
4	Piston	Code Word	Viciston																																																																																																																																																				
5	Crankshaft	Code Word	Vichaft																																																																																																																																																				
6	Eccentric Strap	Code Word	Vicentric																																																																																																																																																				
7	" Sheave	Code Word	Vicheave																																																																																																																																																				
8	Flywheel	Code Word	Vicweel																																																																																																																																																				
9	Cylinder Cover	Code Word	Vicover																																																																																																																																																				
10	Gudgeon Pin	Code Word	Vicgugpin																																																																																																																																																				
11	L.P. Junk Plate	Code Word	Vicplate																																																																																																																																																				
12	L.P. Packing Rings	Code Word	Viclowpack																																																																																																																																																				
13	H.P. " "	Code Word	Vichipack																																																																																																																																																				
14	H. P. Junk Ring	Code Word	Vichijunk																																																																																																																																																				
15	Suction Valve Cap	Code Word	Vicscap																																																																																																																																																				
16	" " Plug	Code Word	Vicsplug																																																																																																																																																				
17	" " Seat	Code Word	Vicseat																																																																																																																																																				
18	" Valve	Code Word	Vicsalve																																																																																																																																																				
19	Delivery Valve Cap	Code Word	Vicdelcap																																																																																																																																																				
20	" " Plug	Code Word	Vicdelplug																																																																																																																																																				
21	" " Seat	Code Word	Vicdelseat																																																																																																																																																				
22	" Valve	Code Word	Vicdeval																																																																																																																																																				
23	" " Spring	Code Word	Vicdepring																																																																																																																																																				
24	Suction Valve Spring	Code Word	Vicsupring																																																																																																																																																				
25	Washer	Code Word	Vicwasher																																																																																																																																																				
26	Drip Lubricator †	Code Word	Viclubr																																																																																																																																																				
27	" Union & Pipe	Code Word	Viclupipe																																																																																																																																																				
28	Locking Screw	Code Word	Vicscrew																																																																																																																																																				
29	Cooling Pipe	Code Word	Viccooler																																																																																																																																																				
30	Water Inlet Plug	Code Word	Vicfiller																																																																																																																																																				
31	Stauffer Lubricator	Code Word	Vicstaffer																																																																																																																																																				
32	Gudgeon Locking Pin	Code Word	Viclokpin																																																																																																																																																				
33	Gib Key	Code Word	Vicgibkey																																																																																																																																																				
34	Lubricator Bracket	Code Word	Viclubrak																																																																																																																																																				
35	Water Outlet Plug	Code Word	Vicwatlet																																																																																																																																																				
36	Bye-pass Valve	Code Word	Vicbypass																																																																																																																																																				
37	Suction Cover †	Code Word	Vicsuov																																																																																																																																																				

† In later supplies of pumps the suction cover 37 is replaced by a filter and the drip lubricator is attached to a bracket on the front plate of the housing.

APPARATUS, ILLUMINATING, SIGHTS N^o 1, 6 & 8 INCH HOWITZER, SIGHTING GEAR.

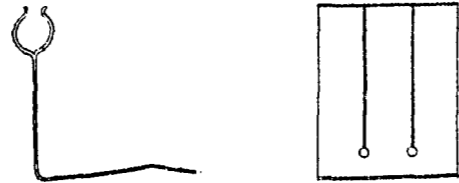

SPRING CLIP.

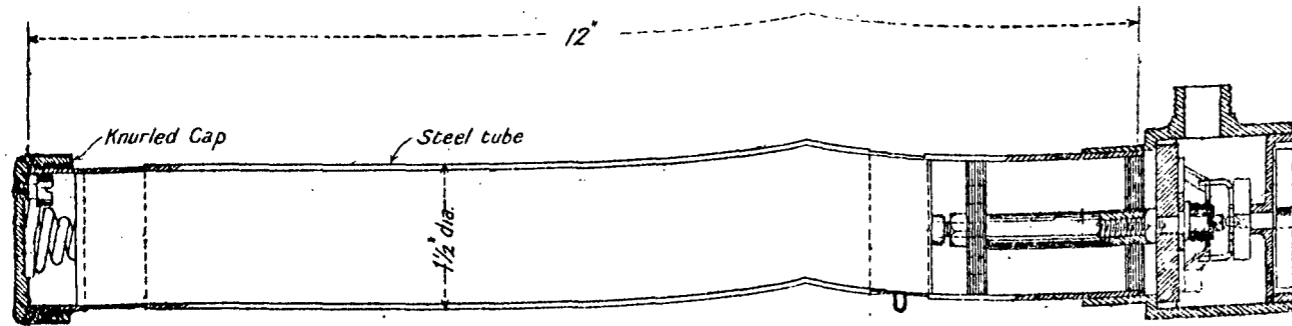

SECTIONAL ELEVATION THROUGH STEEL TUBE AND SWITCH BOX

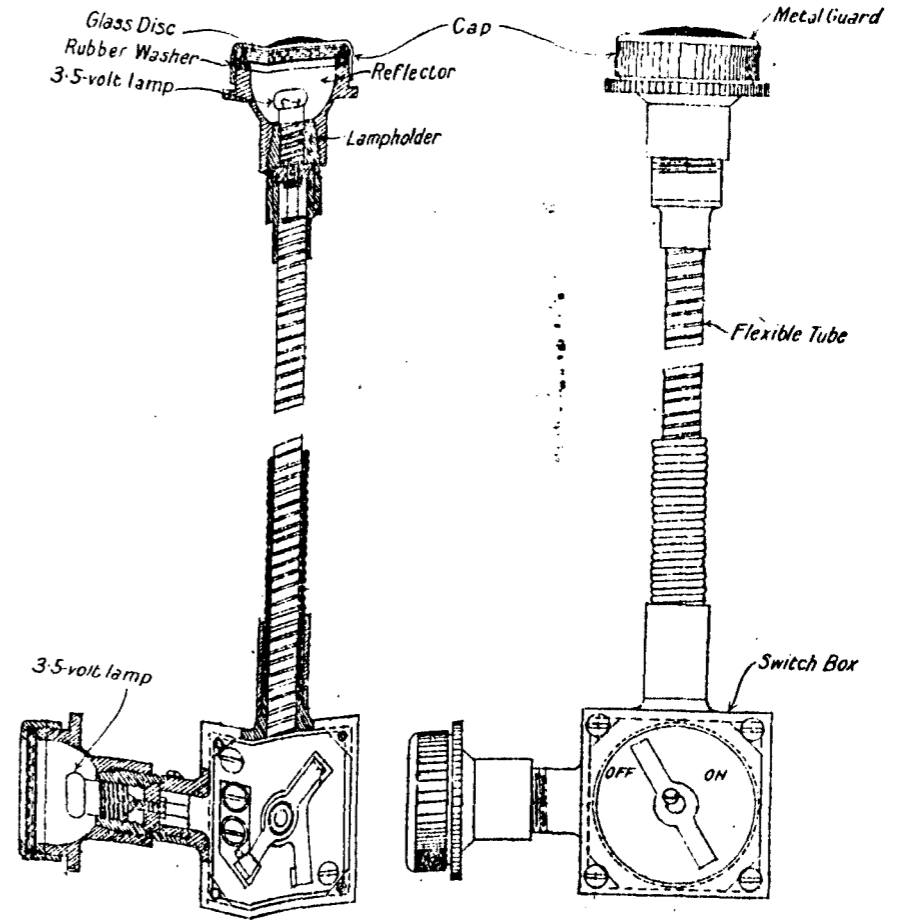

REAR ELEVATION.

SHELL, B. L. HIGH EXPLOSIVE, STREAM-LINE, 6-INCH
HOWITZER, 86-LB. MARK ID.

SCALE = $\frac{1}{3}$

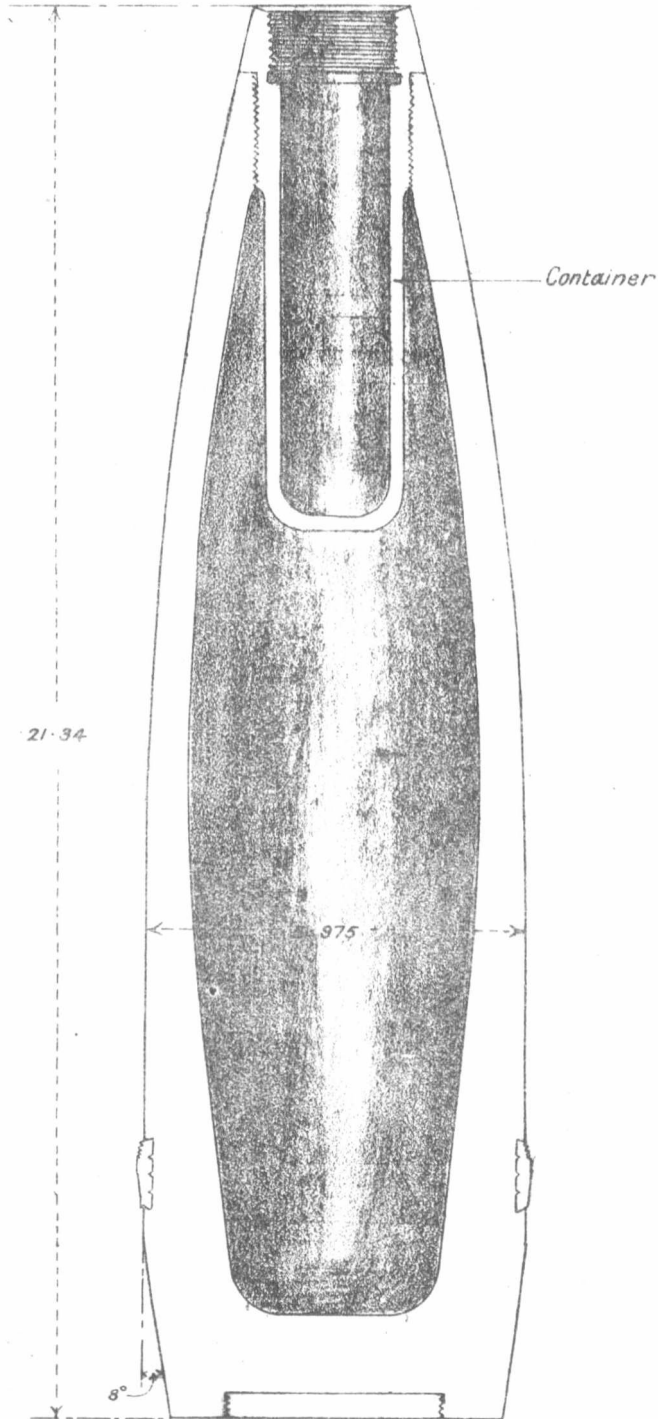

SHELL, B. L. OR Q. F. COMMON POINTED, 6-INCH, MARK **XIII.**

SCALE = $\frac{1}{3}$

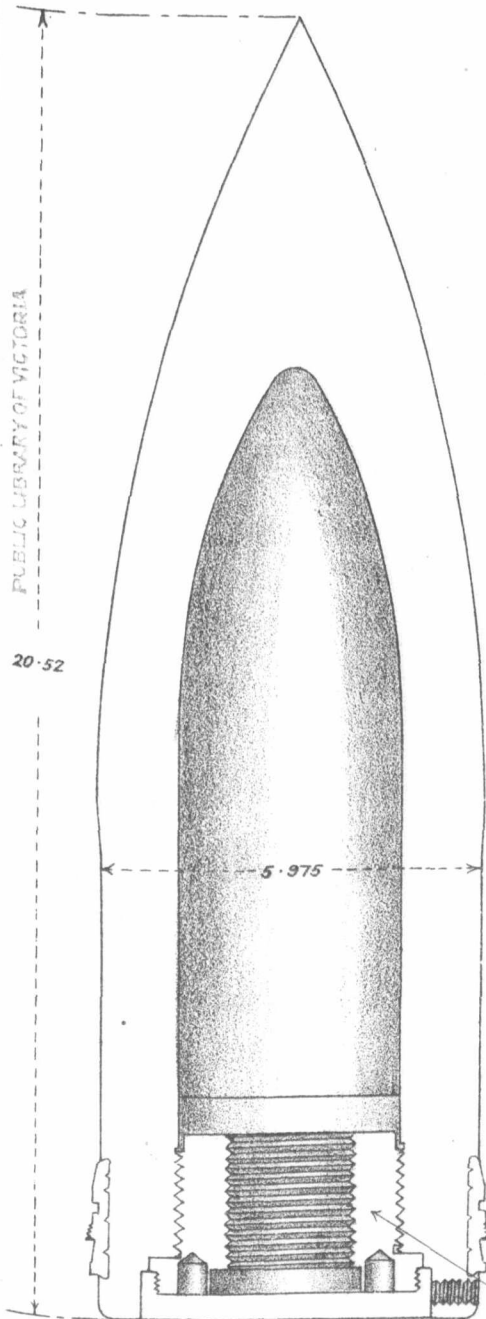

PUBLIC LIBRARY OF VICTORIA

20.52

5.975

BASE COVER PLATE
(IN TWO PARTS)

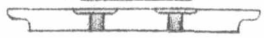

PERFORATED PLATE



SCREWED RING.

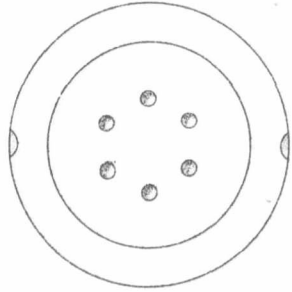

ASSEMBLED
(INVERTED PLAN)

Base adapter.

SHELL, B. L. CHEMICAL, 6-INCH HOWITZER, LIGHT, MARK VIII

SCALE = $\frac{1}{3}$

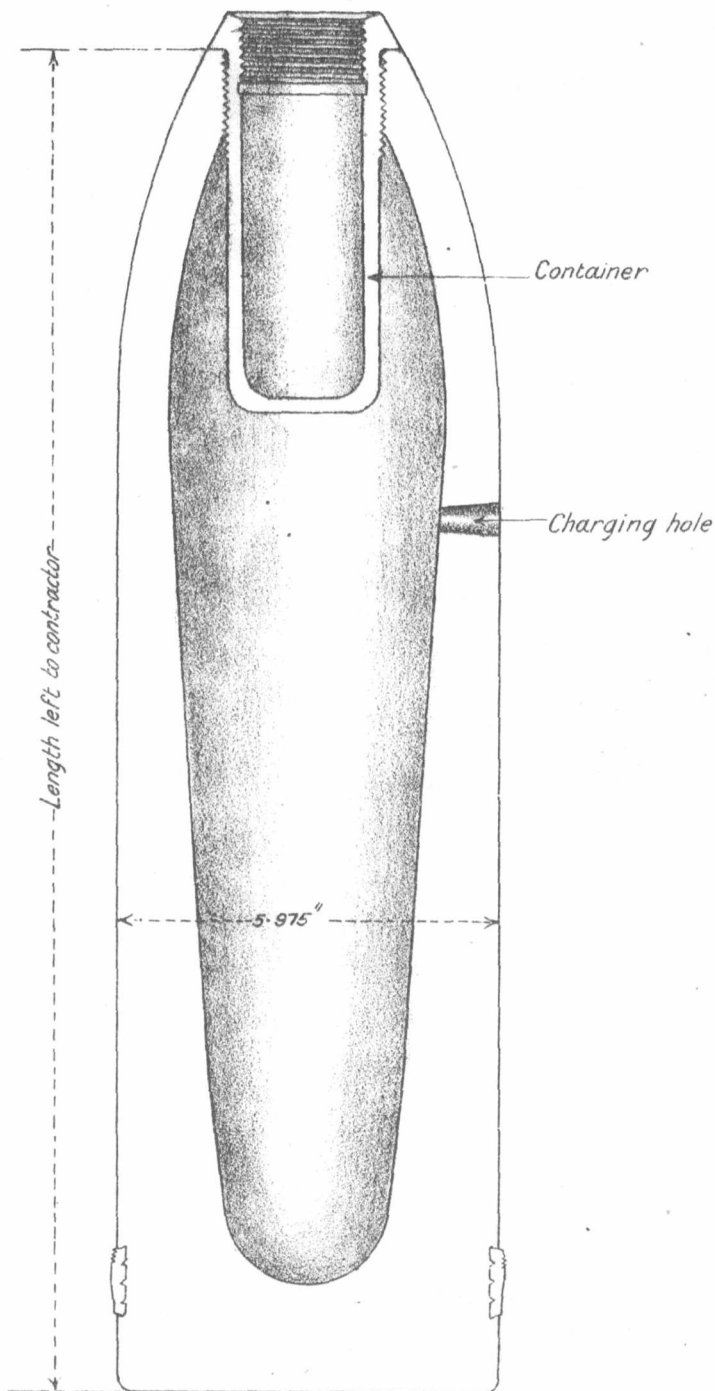

SHELL, B. L. OR Q. F. INCENDIARY, 6-INCH, MARK II.

SCALE = $\frac{1}{3}$

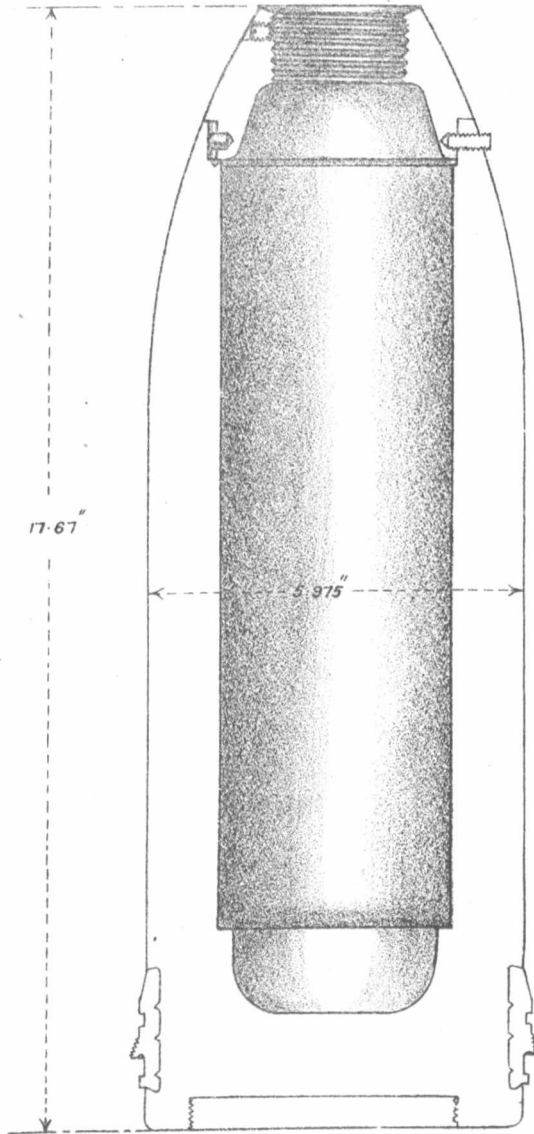

PUBLIC LIBRARY OF VICTORIA

SHELL, B. L., OR Q. F., STAR, 6-INCH, MARK VI.

SCALE = $\frac{1}{3}$

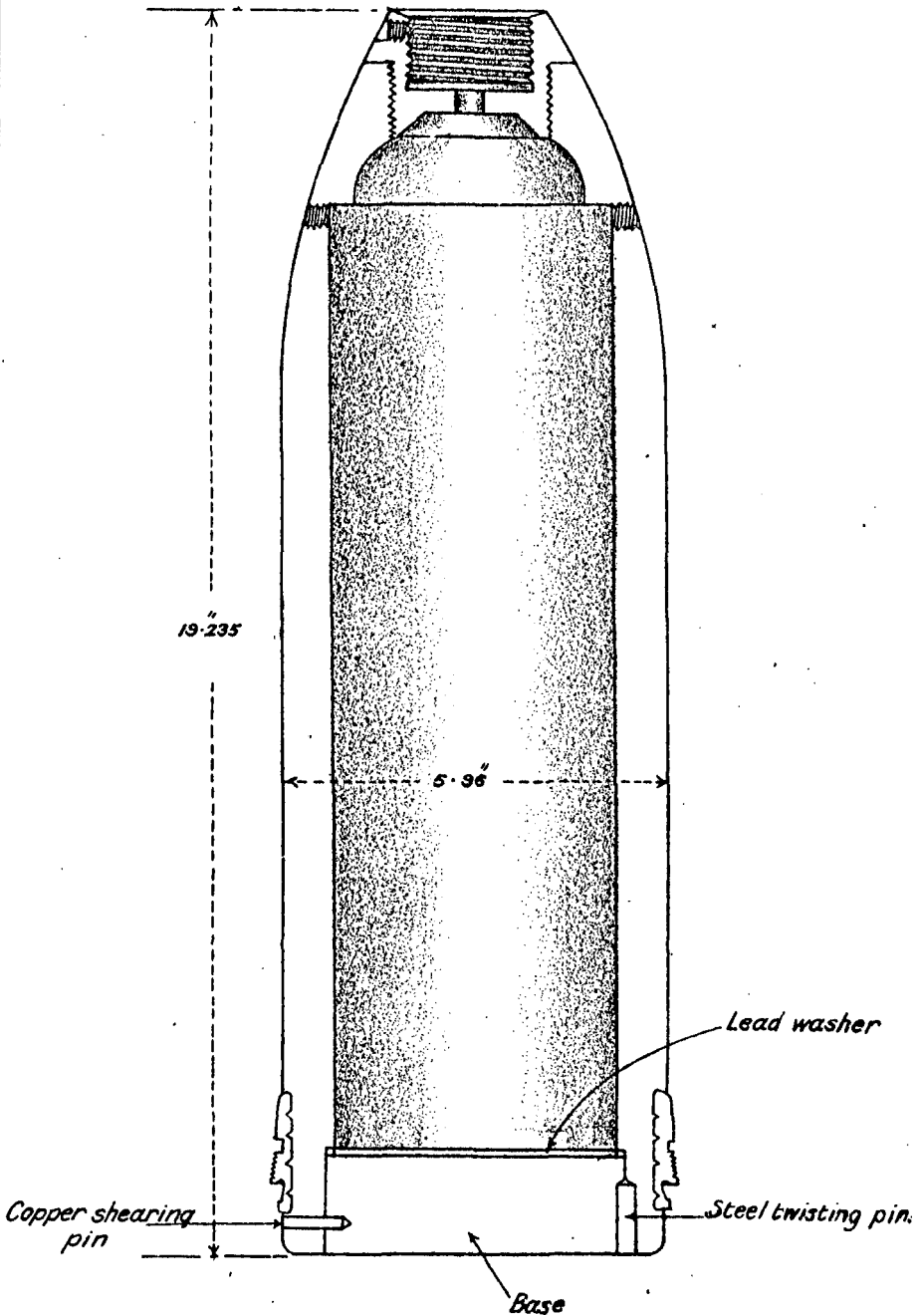

FUSE, PERCUSSION, BASE, LARGE, N° 16, MARK IV.

FULL SIZE.

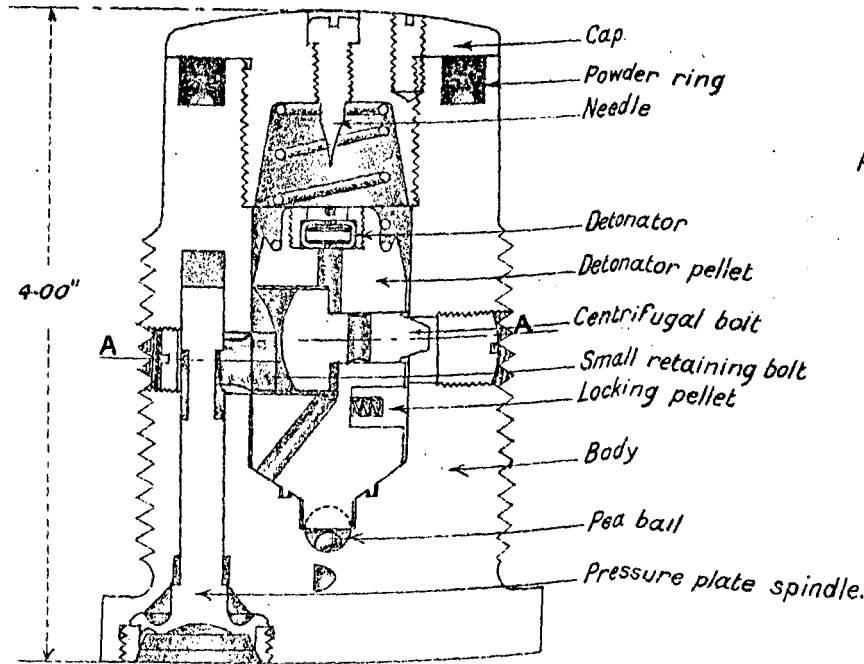

SECTION AT B.B.

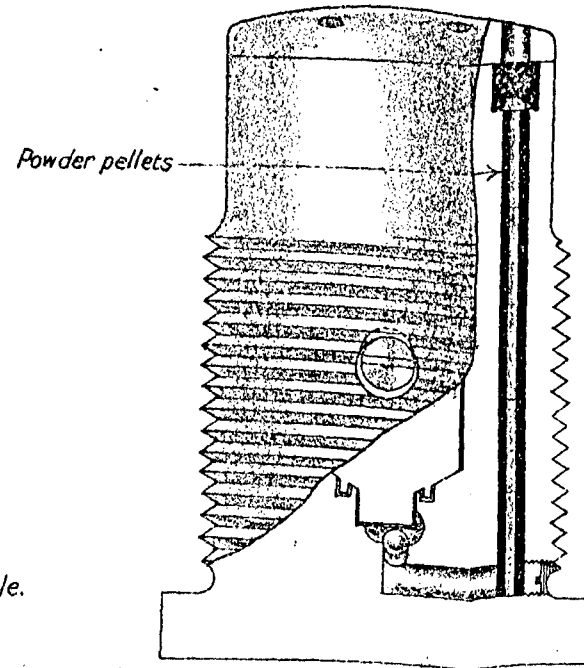

FUZE N° 16
PART SECTION AT C.C.

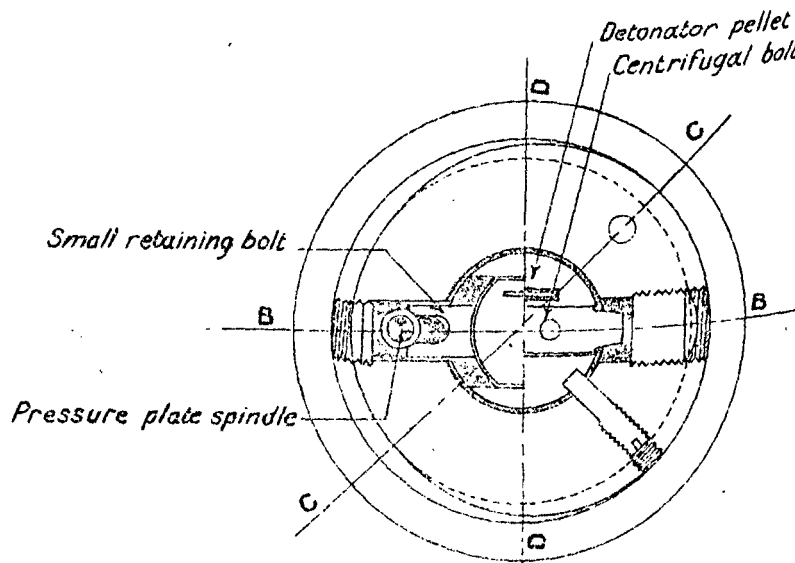

SECTION AT A.A.

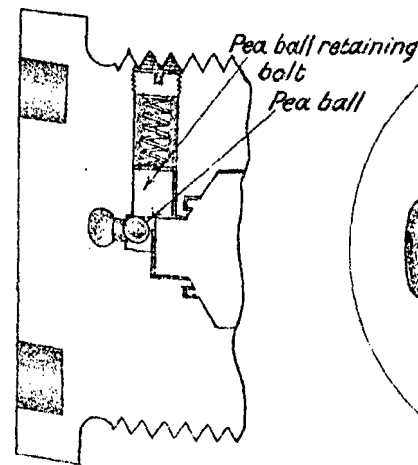

PART SECTION AT D.D.

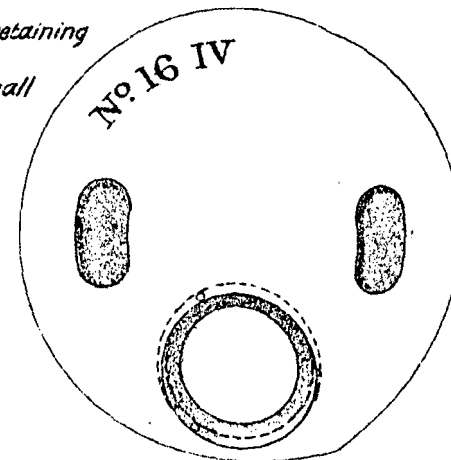

PLAN OF BASE.

FUZE, PERCUSSION, N^o 101 E, MARK II.

ROYAL ARTILLERY LIBRARY

FULL SIZE.

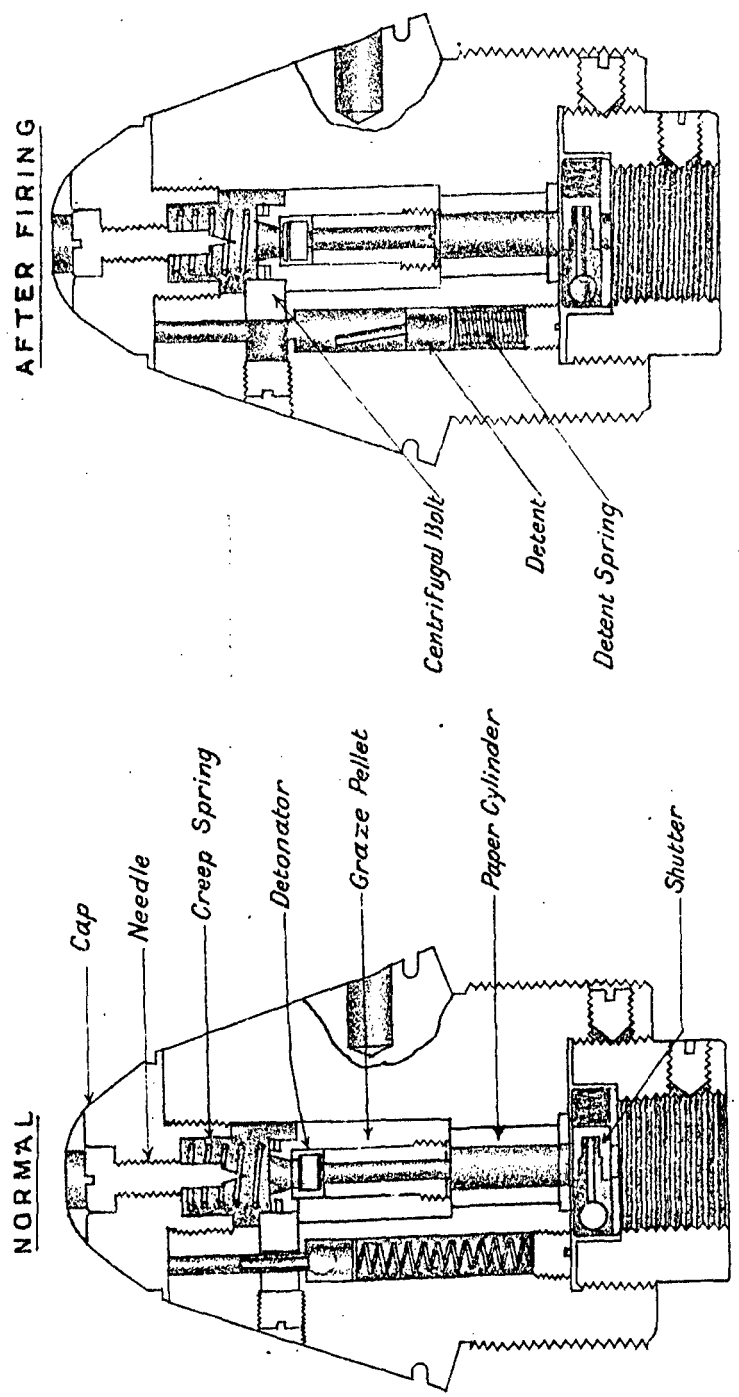

FUZE, PERCUSSION. N° 101^E, MARK II.

FULL SIZE.

DURING FLIGHT

ON GRAZE

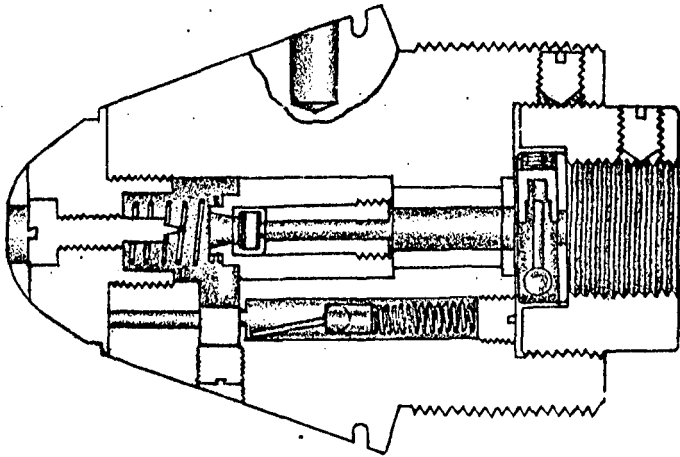
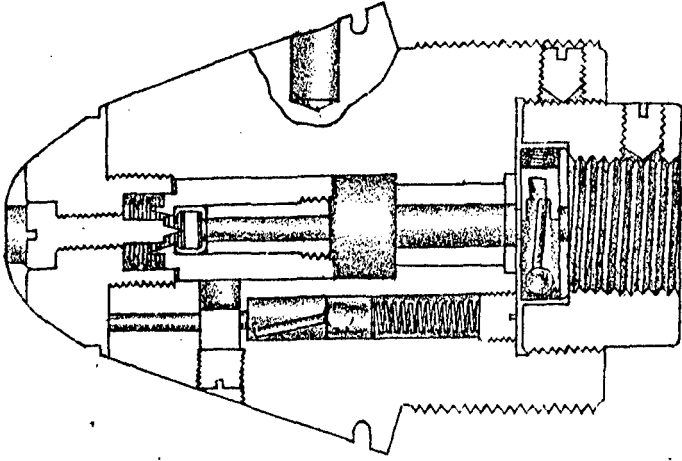

FUZE, PERCUSSION, WITH CAP, N° 106 E MARK IV.

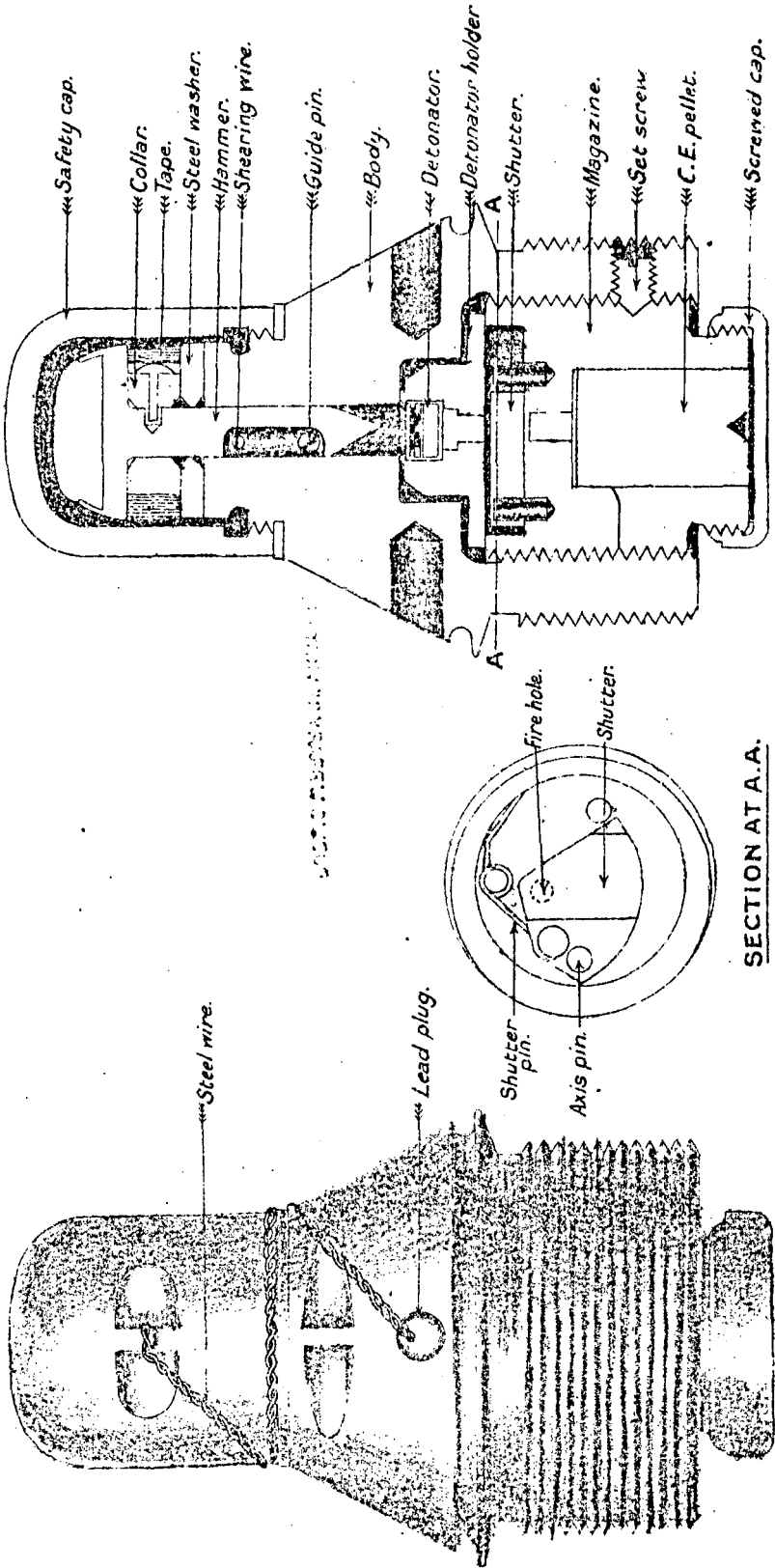

SECTION AT A.A.

FUZE, TIME AND PERCUSSION. N° 82, MARK IV.

SCALE FULL SIZE

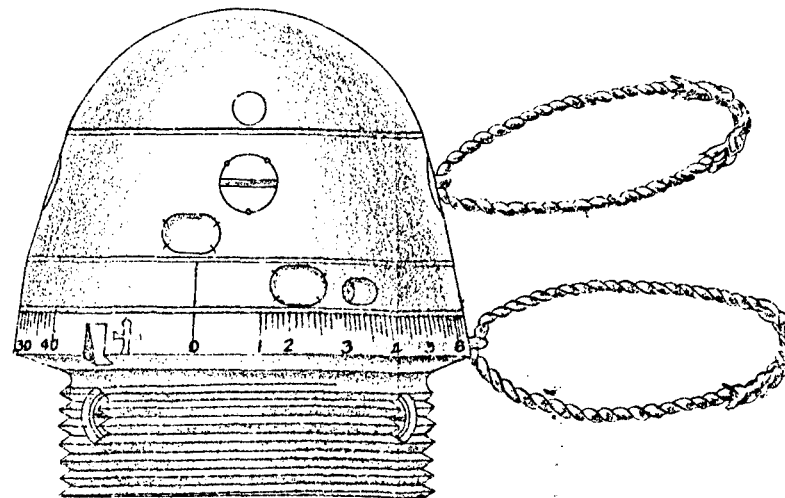
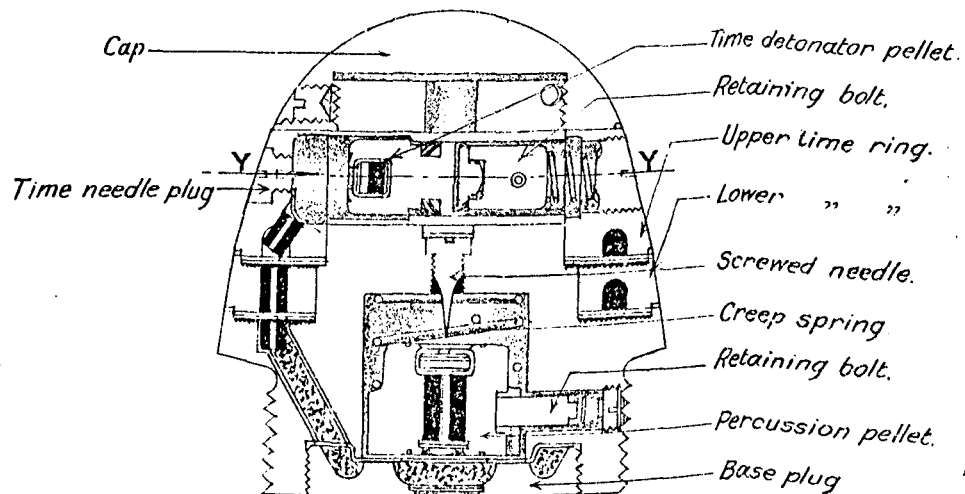

ELEVATION
FUZE SET AT 0.

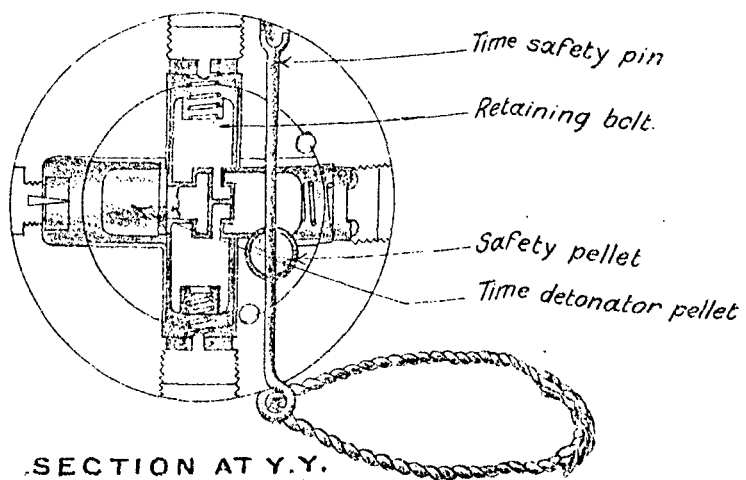

SECTION AT Y.Y.

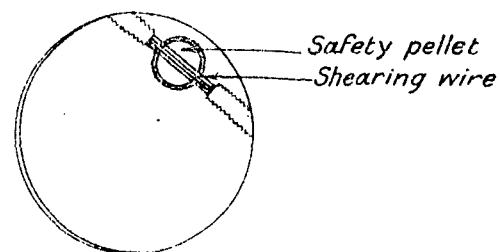

SECTION THRO' SHEARING WIRE
& SAFETY PELLETT.

CARTRIDGE, B.L. 6-INCH 26-CWT. HOWITZER, 4lb. 11½ ozs. CORDITE.

M.D. OR R.D.B. SIZE 8, MARK II.

SCALE = 1/2.

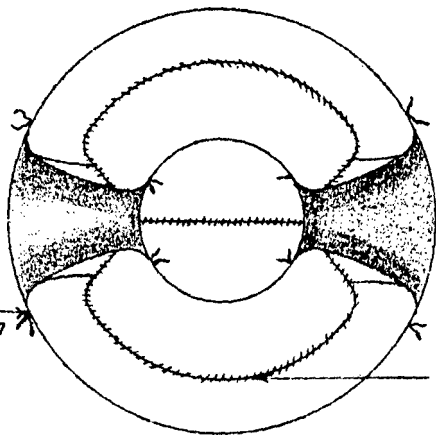
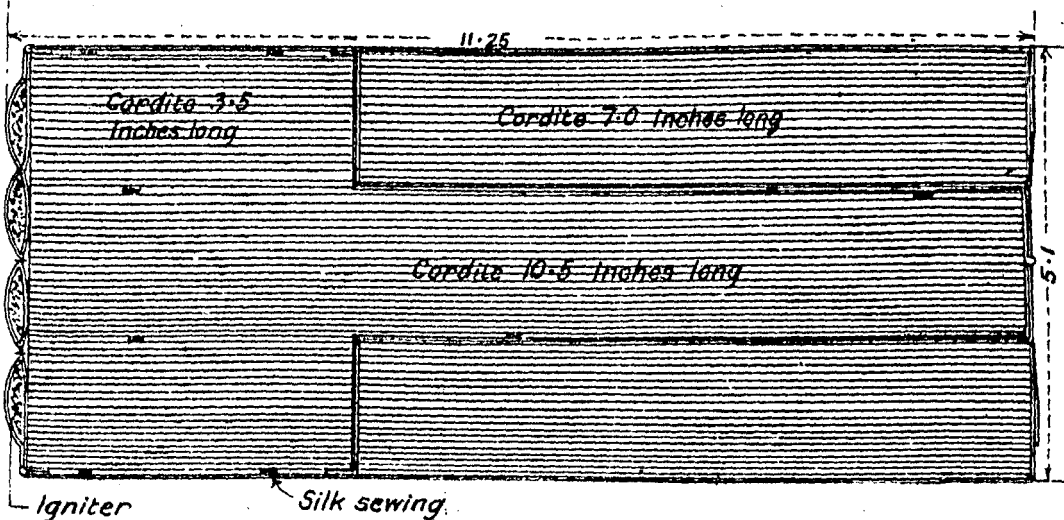

Nos 2 & 3 sections stitched to core in 4 places, 2 on top and 2 at bottom.

Ends of bags turned over and sewn.

TUBE, PERCUSSION, S.A. CARTRIDGE, MARK I.

SCALE=2/1.

