

SUPPLIED FOR THE PUBLIC SERVICE.

HANDBOOK

FOR

HOTCHKISS 6-PR. AND 3-PR.

QUICK-FIRING GUNS.

1915.

BY COMMAND OF THE LORDS COMMISSIONERS OF THE ADMIRALTY.



ADMIRALTY,
G. BRANCH,
G. 7887/1911.
Sta. 64/15.

LONDON:

PRINTED UNDER THE AUTHORITY OF HIS MAJESTY'S
STATIONERY OFFICE

BY EYRE AND SPOTTISWOODE, LTD., EAST HARDING STREET, E.C.,
PRINTERS TO THE KING'S MOST EXCELLENT MAJESTY.

To be purchased, either directly or through any Bookseller, from
WYMAN AND SONS, LIMITED, 29, BREAMS BUILDINGS, FETTER LANE, E.C., and
54, ST. MARY STREET, CARDIFF; or
H.M. STATIONERY OFFICE (SCOTTISH BRANCH), 23, FORTH STREET, EDINBURGH; or
E. PONSONBY, LTD., 116, GRAFTON STREET, DUBLIN;
or from the Agencies in the British Colonies and Dependencies,
the United States of America and other Foreign Countries of
T. FISHER UNWIN, LONDON, W.C.

1915.

NOMENCLATURE.

THE GUN.

Plate I.

Principal Parts.—(1) A, tube; (2) jacket; (3) locking ring; (4) and (5) wedge mortice; (6) wedge guides; (7) extractor guide.

Interior.—Holes in Breech.—(Right side) crank journal; (left side) shoulder-piece fixing screw seat, screw stop wedge seat, stud steadying shoulder-piece seat; (rear face) bracket, tangent sight screw holes; (bottom) trigger-guard screw holes.

Plate II.

Breech Movement.—(8) Crank; (9) crank stud; (10) crank stud groove; (11) crank handle; (13) stop screw for wedge; (14) stop screw groove; (15) wedge plate.

Firing Mechanism.—(16) Hammer; (17) firing pin; (18) rocking shaft; (19) main spring; (20) hammer stirrup; (21) main spring rest; (22) trigger-sear; (23) trigger-sear spring; (24) trigger; (25) cock notch; (26) cocking toe; (26a) re-cocking handle; (27) cocking cam; (28) trigger guard, and spring retaining trigger.

Extraction.—(29) Extractor; (31) extractor stud; (32) extractor stud groove.

Plate III.

Accessories, Shoulder-piece.—(33) Shoulder-piece fixing screw; (34) stud steadying shoulder-piece; (35) shoulder-piece buffer tube; (36) shoulder-piece handles; (37) deflector.

Sights.—(38) Fore sight; (39) tangent sight; (40) bracket tangent sight; (41) rack and pinion; (42) deflection leaf; (43) tangent screw.

Supplies.—(44) Oil can; (45) tommy for dismounting; (46) screw-driver; (47) hand extractor; (49) brush sponge, with rod.

The Body.—The body of the Hotchkiss 3-pr. and 6-pr. quick-firing guns consists of three pieces of oil tempered steel: the tube, extending from the face of the muzzle to the front face of the wedge, comprising the whole length of bore; the jacket, which is shrunk over the rear part of the tube and which carries both the trunnions and the wedge; the locking-ring, a screwed collar connecting the tube and jacket and which carries the fore sight. By this construction the tube bears the main transverse stresses, the jacket bears all the longitudinal stresses, the locking-ring ensures against the displacement of the tube and jacket.

The Rifling.—The bore is rifled with a right-handed twist; that of the 3-pr. is uniform in pitch, and that of the 6-pr. increasing. The lands of both guns are very narrow in proportion to the grooves, and are twenty in number in the 3-pr. and twenty-four in the 6-pr.

The Wedge (4).—The wedge is a square hollowed steel block with rounded corners, having a vertical movement in a mortice cut completely through the jacket. The front face of the wedge is perpendicular to the axis of the bore, whilst the rear face is slightly inclined. The front upper corner is cut back to allow free movement to the extractor. In the hollowed part of the wedge is contained the firing mechanism.

The Wedge Plate (15).—That part of the front face of the wedge which covers the bottom of the bore consists of a removable hard steel face dovetailed into the face of the block and secured by two screws. This wedge plate has a removable steel bush with a hole in the centre through which the firing pin acts on the cap of the cartridge.

By the movement of the wedge the breech is opened or closed, the empty cartridge case is extracted, and the firing mechanism is cocked.

The Crank (8).—The wedge is moved and also held fast when closed by the crank, which has a small stud (9) and roller in its end travelling in a groove (10) in the wedge. The crank is journalled in the right cheek of the mortice and carries on its stem the crank handle (11) and cocking cam (27).

Catch retaining Crank Handle.—A catch retaining crank handle (27a) is fitted on the right side of the gun at the breech, in such a position as to engage on the under side of the cocking cam, when the breech is in the closed position. It consists of a steel plunger and a spiral spring contained in a steel bracket. The bracket is secured to the gun by a feather and two screwed rivets.

The Hammer (16).—The hammer is mounted in the middle line of the wedge and carries a detachable point or firing pin (17), which acts on the cap of the cartridge through a hole in the wedge plate.

In the newer type of hammer the firing pin is dropped into the dovetailed holder. It is mounted on a rocking shaft (18), which has a toe (26) on the outside of the breech. When the crank is turned to lower the wedge, a cam (27) mounted on the crank stem is brought against the cocking toe of the rocking shaft, thus throwing the hammer back and cocking it. It is also fitted with a handle (26a) for re-cocking after a missfire.

In the latest pattern rocking shaft Mark IV., the re-cocking handle is forged solid with the shaft and has been slightly altered in shape for convenience in handling.

The Trigger-sear (22).—The hammer is held at a full cock by means of a trigger-sear actuated by a spring (23), both being secured in the bottom of the wedge. The end of the sear catches in a cock notch (25) on the axis of the hammer.

The Trigger (24).—A loose trigger is carried in a trigger guard (28) secured to the rear of the breech; when the wedge is closed this trigger is brought in contact with the sear, so that by pulling it the sear is pressed down until its end slips clear of the cock notch, allowing the hammer to fly forward and fire the gun.

Spring retaining Trigger.—In order to prevent the gun being fired prematurely, when on the recoil mounting, a "spring retaining trigger" has been introduced, and is to be fitted to the trigger guard, being secured by two fixing screws. With this spring in position the "pull-off" is increased to between 30 and 40 lbs. It must be distinctly understood that the "spring retaining trigger" should only be kept in the gun when it is on a *recoil mounting*, and when mounted on a *frame stand* the spring should be removed and put away with the spare parts.

The Main Spring (19).—The main spring is double branched and is so fitted as to make both of its branches work on the hammer on opposite sides of the axis of rotation, thus gaining the full power of the spring with almost frictionless rotation. One branch of the spring lies in a rest (21) on one side of the axis, and the other end hangs in a stirrup (20) on the other side. This stirrup also holds the rocking shaft in place.

The Extractor (29).—The extractor is a single piece of steel working in a longitudinal groove (7) in the left cheek of the mortice. Its forward end is shaped into a hook to grasp the

head of the cartridge. On the same side of the extractor as the hook is a small stud (31) which travels in a groove (32) in the wedge, thus giving motion to the extractor.

A strengthened extractor has been fitted in newer guns.

The Shoulder-piece.—The shoulder-piece (which is only issued for guns mounted on *frame stands*) is attached to the left side of the gun by three fastenings—the top screw for the wedge (13), the shoulder-piece fixing screw (33), and the stud steadying shoulder-piece (34). On the vertical arm of the shoulder-piece is fixed a buffer (35) of rubber tubing, which prevents the shock of discharge being felt. The upper end of the tubing is protected by a brass cap. The lower end of the arm is provided with handles (36) to facilitate holding the gun. In order to prevent the extracted cartridge cases from falling on the feet, a deflector (37) is attached to the arm of the shoulder-piece. In the case of guns on *recoil mountings* the shoulder-piece fixing screw (33) and the stud steadying shoulder-piece (34) are both removed and the holes fitted with preserving screws, as if left in the gun in the case of the 6-pr. the fixing screw would foul the shoulder-piece of mounting on recoil.

The Stop Screw for Wedge (13).—When the wedge is run down, it is prevented from dropping clear out of its mortice by a stop screw for the wedge (13), screwed through the left cheek of the mortice, its end travelling in a groove (14) in the left face of the wedge.

The Trigger Guard (28).—The trigger guard secured to the right lower side of the breech carries the trigger (24) and also aids in holding and handling the gun.

The Sights.—The sights are of the usual "H" form graduated in the case of the 6-pr. to 4,000 yards, and for the 3-pr. to 3,400 yards. The speed scale on the tangent sight is marked up to 30 knots each way.

THE ACTION OF THE MECHANISM.

The gun having been fired, the action of the mechanism in re-loading is as follows:—

Cocking.—Opening.—Extracting.—The breech is opened by pulling the crank handle to the rear. As the crank handle commences to move the crank stud is carried backward in the part of its groove which is concentric with the axis of the crank, therefore the wedge does not move; during this time the cocking cam acts on the cocking toe and cocks the hammer. The crank stud passing on into the inclined part of its groove, the wedge commences to descend. The extractor

actuated by the movement of the wedge, commences to move very slowly back with a powerful leverage, starting the cartridge case from its seat. When the wedge has descended so far as to unmask the bore, the change in direction of the extractor stud groove causes the extractor to take a quick violent motion to the rear, throwing the cartridge case entirely out of the gun. The wedge is at this point stopped in its descent by the stop bolt.

Loading.—The gun is ready for loading.

Closing.—Closed.—The new cartridge having been entered in chamber, is pushed home until the rim of the case takes against the hook of the extractor; the wedge is closed by a reverse movement of the crank handle. As the wedge rises, its inclined upper corner pushes the cartridge and extractor close home. When the wedge is entirely up, its face bears tightly against the base of the cartridge and the crank has passed the vertical position and rests against the body of the gun, so that the wedge is held secure in three ways: its own weight pressing on the crank past the centre, by the reaction of the crank and handles in firing, and by the catch retaining crank handle.

Ready.—Firing.—When the breech is closed the cocking cam is in position to allow the cocking toe, and with it the hammer, to act in firing. The top branch of the trigger also rests against the sear. On pulling the trigger its top branch presses down upon the sear, releases it from the cock notch, and the hammer flies forward striking the cap of the cartridge.

NOTE.—Care should be taken to see crank handle properly forward before firing, otherwise the force of the main spring is partially expended in bringing the crank handle into the correct position, thus tending to cause missfires.

Safety.—It is impossible to fire the gun before the breech is entirely closed, for three reasons, viz.: The firing pin is not in line with the cap; the trigger will not act on the sear; the cocking toe will catch on the cocking cam before the firing pin can touch the cap.

It is impossible for the breech to fly open, for three reasons (*see Closed*).

It is impossible to bring a shock on the cap in closing the breech, as the face of the wedge *slides along* the base of the cartridge, thus giving perfect security in loading and unloading.

CARE AND CLEANING REQUIRED.

The guns require no special care beyond that of being kept clean, free from rust, and undefaced.

Brick dust or gritty substances must never be used on any part of the gun.

The parts of the mechanism must never be scraped with knives or metal, or be defaced or roughened in any way.

All parts of the gun must be kept lightly oiled as a protection from rust.

Always, after firing, the gun should be thoroughly cleaned. To do this, dismount the mechanism completely and wash every part thoroughly with warm fresh water soap suds; mechanism, wedge, mortice and barrel should all be treated alike.

After thoroughly scrubbing all parts, dry them carefully and let all stand for a short time to air and dry off the moisture.

After drying, rub all parts over with a well-oiled rag.

Mount the mechanism.

Keep the gun covered whenever there is a chance of getting grit or salt water on it.

Inspect and re-oil once a week. In re-oiling always first wipe off all the old oil which has become clogged with dust and grit.

DIRECTIONS FOR MOUNTING AND DISMOUNTING.

The Shoulder-piece.—Turn the top screw for wedge (13) and the shoulder-piece fixing screw (33) a quarter turn with the tommy; the shoulder-piece is then loose and will come off the gun.

The Wedge.—The breech being closed, partially unscrew the top screw (13) by backing it about four turns. Start the crank handle back and ease the wedge down out of its guides, holding it with the hands as it comes out of the mortice.

The mechanism may be dismounted with the breech block either in or out of the gun. *First uncock the hammer*; if the breech is closed and the gun not loaded, this will be done by pulling the trigger; if the breech is open or the wedge is out of the gun, it will be done by pressing down on the sear.

The Main Spring.—The Hammer.—Insert the point of the screw-driver in the seat of the bend of the main spring, so that the fulcrum side of the blade of the screw-driver will be flat on the branch of the spring (*see Plate IV.*); press down and slip the stirrup (20) off the end of the spring. Take out the main spring. Turn the stirrup to a horizontal position, so as to unlock the rocking shaft (18). Pull out the rocking shaft and remove the hammer.

The Trigger Gear.—With the point of the screw-driver back out the sear spring, which is dovetailed in its seat (*see Plate IV.*).

Take off the sear.

The Crank.—Take out the keep screw in the hub of the crank handle and pull the latter off the stem of the crank. Take out the crank.

The Extractor.—Withdraw the extractor from its groove. Proceed in the reverse way in mounting; *the hammer must be at full cock when inserting the rocking shaft*, and if to be mounted on a frame stand the "spring retaining trigger" should be left out.

THE NON-RECOIL MOUNTING, OR ELASTIC FRAME STAND.

NOMENCLATURE.

Plate V.

(1) Cap squares; (2) cap square clamping screws; (3) pivot clamping screw; (4) pivot; (5) socket; (6) elastic stand; (7) shield; (8) shield stays; (9) clamp.

DESCRIPTION.

The Pivot and Socket.—The gun-metal pivot is fork-shaped, and supports the gun entirely by its trunnions. The cap squares are screwed down instead of being fitted in the ordinary manner, as, in order to prevent damage to the metal through the shock of recoil, the trunnions must fit exactly all around in their bearings. The pivot fits into a gun-metal socket, with just sufficient play to allow it to rotate freely. The two parts together form an universal joint for the gun, giving it free play for aiming in any direction.

The Elastic Stand.—The elastic stand is formed of the socket, about which are secured eight iron legs, which diverge and are attached to a D-shaped base ring, so that the gun may be mounted close out to a rail or bulwark. The ten bolts which fasten the stand down to the deck pass through the base ring and also through the legs.

The gun is secured by means of three clamps, one bearing on the pivot, the other two gripping the trunnions.

Several cases having occurred of fractures developing in the pivot below the trunnion bearings, care should be taken to carefully examine these mountings on all occasions before firing.

RECOIL MOUNTINGS, 3-PR. MARK I. AND 6-PR. MARK I.

NOMENCLATURE.

Plates VI. and VII.

Nomenclature.—(1) Base plate; (2) clip ring; (3) revolving bracket; (4) pivot bolt; (5) carriage; (6) trunnion boxes; (7) hydraulic cylinders; (8) spring cylinders; (9) piston; (10) piston rods; (11) stuffing boxes; (12) clamping arc; (13) clamps; (14) shoulder-piece; (15) deflector; (16) lanyard; (17) trigger guard; (18) firing lever; (19) 6-pr. only, attaching band.

DESCRIPTION.

This mounting is designed for use in torpedo boats, steam launches, or on decks whose beams are of too light a scantling to resist the stresses obtained with the non-recoil mounting. It is arranged to be trained and fired directly from the shoulder. At all angles of elevation and depression, the axes of the bore and the recoil cylinders are in the same plane, so that all destructive shocks on mounting and platform are absorbed by the hydraulic cylinders.

This mounting has superseded the non-recoil mounting in all recent ships, as it brings much less stress on the deck on firing.

The Base Plate.—The base plate is a hollow wrought iron forging closed on top, which supports the moving parts of the mounting. A circular recess in the upper surface receives the pivot bolt. The lower part is shaped to fit the holding down ring.

A lightened pattern of base plate has been introduced for the built up mounting referred to below.

The Clip Ring.—The clip ring is a bronze flange ring which holds the base plate and revolving bracket together whilst permitting the latter to rotate in training.

The Revolving Bracket.—The revolving bracket is a fork-shaped steel casting, with bearings for the trunnions of the carriage. It is tapped in the centre to receive the pivot bolt which supports the whole system.

The latest pattern of revolving bracket is built up of cast-steel plates, and is lighter than the older pattern. It consists of the bottom plate tapped in the centre to receive the pivot bolt, and of two brackets each carrying a bronze casting with a bearing for the trunnion of the carriage. The brackets are secured to the bottom plate by angle irons.

The pivot bolt can be adjusted without dismounting the carriage.

The Carriage.—The carriage is a single bronze casting, which supports the gun in trunnion boxes.

A later lightened pattern has been introduced, together with the built up revolving bracket; considerable weight is saved by cutting holes in the casting where permissible.

The Trunnion Boxes.—The trunnion boxes are steel castings, which rest on the carriage to which they are secured by stout clips.

The piston rods are screwed into the front end of the trunnion boxes and the spring acts on their rear side; in the 3-pr. mounting the trunnion boxes merely bear against the front end of the spring cylinder; in the 6-pr. mounting a bracket forming part of the trunnion box extends downwards, and is attached to the rod of the spring cylinder. In the 6-pr. mounting a band is placed round the gun behind the trunnions, and is bolted to the rear sides of the trunnion boxes.

To make the 6-pr. mounting interchangeable among the three natures of guns—Hotchkiss and Nordenfelt Marks I. and II.—different sets of trunnion boxes and attaching band are made, each of which are capable of working in the carriage.

The Cylinders.—The hydraulic and spring cylinders are part of the casting which forms the carriage. The former are of the coned type, and are provided with stuffing boxes for the passage of the piston rods. The pressure in the two is equalized by a connecting channel passing through the front part of the carriage. The spring cylinders contain heavy coiled springs under an initial compression; in the 3-pr. mounting the cylinder is telescopic, the rear or outer part being made in the casting of the carriage, while the front or inner part is removable and slides within the fixed part; in the 6-pr. mounting the whole cylinder is formed in the casting of the carriage; a steel rod runs through it having a cap attached at its front end, and the rear end being attached to the bracket of the trunnion box, the spring is thus compressed between the cap and the rear end of the cylinder. The energy of recoil is absorbed by the hydraulic cylinders, and the gun is immediately returned to the firing position by the springs.

The Shoulder-piece.—The shoulder-piece, similar to but not interchangeable with, the one used for the non-recoil mounting, is bolted to the left cheek of the carriage instead of to the gun itself.

The shoulder-piece of the 6-pr. mounting is reversible to render it applicable both to Nordenfelt guns which are sighted on the left, and to the Hotchkiss gun which is sighted on the right.

A lightened shoulder-piece is supplied with the 6-pr. lightened mountings, weight being saved by cutting oval-shaped holes out of the web.

The Lanyard and Firing Bolt.—The gun is fired by means of a firing bolt placed over the trigger and passing through the pistol grip; in the 3-pr. mounting a wire lanyard is attached to the rear end of the bolt and passes through a hole in the deflector, a “Turk’s head” being worked on it on the fore side of the deflector to prevent the gun being fired unless it is right out in the firing position; in the 6-pr. and later 3-pr. an adjustable wire lanyard attaches the firing bolt to a firing lever which is attached to the deflector. A metal guard is placed round the trigger to prevent the gun being fired from the finger. The firing bolt must move freely in the hole through the pistol grip, so as to ensure its going forward as the breech is closed, otherwise there is a possibility of the gun being fired prematurely. To assist the firing bolt forward a spring has been fitted underneath the trigger, which should be in place when the gun is on the recoil mounting.

NOTE.—3-pr. recoil mountings are fitted with a firing lever as in 6-pr.

RECOIL MOUNTINGS, 3-PR. MARK I*. AND 6-PR. MARK I*.

Plate VIII.

These differ from the Recoil Mountings Mark I., in that they are fitted with a telescopic sight on the left of the gun and an automatic brake on the right of the gun.

The Sight.—The sight bracket is secured to the carriage by a large bolt screwing into the left trunnion, and further secured in the 6-pr. mounting by a bracket on the rear end of the recoil cylinder, and in the 3-pr. mounting by a bracket on the spring box. The telescope used is of 2 inch diameter, 6 power illuminated; Pattern 1697 A.

The Shoulder-piece.—The shoulder-piece is bent and is secured to the left of its bracket instead of in rear to allow the gunlayer to see through the telescope.

The Firing Lever.—The firing lever is carried on a bracket on the right of the deflector instead of being directly secured to the deflector.

The Automatic Brake.—On the right side of the mounting an automatic brake is fitted to clamp the gun in elevation on recoil. A crank is fitted on the screwed shaft of the elevating clamp and is operated by a rod connection to the recoiling part of the mounting. Separating the crank from the arc of the elevating clamp are two Bellville washers. On firing, the crank being forced to the rear, moves outwards on its screwed shaft, thus binding the clamping arc and so clamping the gun.

MOUNTINGS CONVERTED FOR HIGH ANGLE FIRE.

Plate IX.

A large number of Mark I^o. 3-pr. and 6-pr. mountings have been converted for high angle fire by removing the original side plates of the built-up revolving brackets and substituting new and higher plates which allow of an elevation of 60° being given to the gun.

To strengthen the bracket and prevent the side plates from opening out they are connected by three steel stays as shown in *Plate IX*. Since the arrangement of the new side plates throws the trunnion axis to the rear of the vertical pivot bolt instead of directly above it, balance is restored by fitting a counterpoise of pig iron ballast on the front of the revolving bracket. The night sight battery is conveniently shipped on top of this.

An open sight is fitted on the left trunnion and the shoulder piece slightly modified to allow of attaining the maximum elevation.

INSTRUCTIONS FOR ASSEMBLING.

1. Place spring and metal stud of training clamp into bearing, and secure by keep screw. Place revolving bracket on base plate.

2. Place clip ring in position, and seeing key on bracket takes in keyway of ring, secure by two bolts.

3. Screw in pivot bolt and adjust so that revolving bracket revolves freely, then secure by keep screw.

4. Place carriage in bearings on revolving bracket, and place cap square and key.

5. Place elevating arc and stop stud, and screw clamping screw with washer into carriage. Place clamp lever so that in clamping it will be uppermost, and will bring up against stop when unclamping.

6. Insert training clamp screw into bearing and place lever uppermost.

7. Screw stuffing boxes into rear end of hydraulic cylinders, seeing leather washers in place.

8. Pass piston rods through cylinders, stuffing boxes, and glands.

9. Place trunnion boxes on carriage, screw in piston rods, and secure by split pin.

10. Push trunnion blocks to the rear, pack stuffing box, and set up gland.

11. Screw cylinder caps on fore ends of cylinders, placing washer.

12. 3-pr.—Place spring box through spring cylinder, place spring in cylinder and screw on cylinder cap.

6-pr.—Place spring in cylinder, place run-out rod, and attach it to trunnion box bracket.

13. Place gun in trunnion blocks, place cap squares, and secure by split pin. In 6-pr. place attaching band.

14. Give gun extreme depression, fill both cylinders, and replace air plugs.

15. Attach shoulder-piece to carriage and secure by two bolts.

ACCIDENTS.

Jammed Cartridge.—If, in loading, a cartridge jams and will not let the wedge close, *never attempt to drive it home by forcing the wedge*; unload at once, put the cartridge aside and try another.

Non-extraction.—If for any reason the cartridge case or cartridge will not extract, catch the head with the hand extractor and pull it out. If this fails, ram it out from the muzzle.

Broken Extractor.—If the nib of the extractor breaks, back the stop screw clear of the wedge, lower the wedge until the extractor slot is clear, pull out the extractor and insert the spare one. *Do not insert the spare extractor with a cartridge already in the gun*, as the hook will come on the wrong side of the cartridge head.

Broken Mechanism.—If a firing pin, main or sear spring breaks, take out the broken part and put in the spare one.

Missfires.—When a cartridge missfires, a second blow is to be given by re-cocking with the re-cocking handle. Should it missfire at the second attempt, after waiting a pause of 15 minutes, the breech is to be opened carefully, the cartridge withdrawn, and, if the cap has been struck, thrown overboard. If missfires repeatedly occur, remove the wedge at once and feel the firing pin to see if it is broken. If it is not, and everything looks right, change the main spring before putting the wedge back.

Missfires have occurred through the hole in the hammer for the rocking shaft becoming worn. When this is the case, and the gun is fired, tangential force, as the hammer flies forward, takes up the wear, and the firing pin in consequence hits the top of the firing hole.

When it is found that much wear has taken place the hammer should be shifted.

Chamber disfigured.—If, after firing, the cartridge case sticks after partial extraction, feel for a burr about the edge of the chamber; careless loading may cause the hard point of the shell to knock up a burr just sufficient to clinch the case on firing. If such exists it must be filed off smooth.

Before assembling the main spring it should be gauged by the gauge supplied on the lid of spare part box.

It should be noted that 3-pr. and 6-pr. main springs cannot be relied on to give identical results in different guns.

TABLES OF WEIGHTS AND MEASUREMENTS.

GUNS.

| | | 3-pr. I. | 6-pr. I. | 3-pr. I*. | 6-pr. I*. |
|--|------|----------|----------|-----------|-----------|
| Diameter of bore between lands. | in. | 1.85 | 2.244 | — | — |
| Diameter of bore between grooves. | " | 1.88 | 2.268 | — | — |
| Equivalent diameter of cross section. | " | 1.87 | 2.256 | — | — |
| Maximum diameter of chamber. | " | 2.283 | 2.709 | — | — |
| Length of chamber to base of shell. | " | 15.638 | 12.943 | — | — |
| Length of bore in calibres | " | 40 | 40 | — | — |
| Total length of gun | " | 80.63 | 97.63 | — | — |
| Extremelength, including shoulder-piece. | " | 100.40 | 118.89 | 100 | 116.3 |
| Length of rifle bore | " | 58.347 | 76.91 | — | — |
| Number of grooves | " | 20 | 24 | — | — |
| Angle of rifling | deg. | 5.40 | 1 to 6 | — | — |
| Diameter of trunnions | in. | 2.75 | 3.346 | — | — |
| Distance between shoulders of trunnions. | " | 6.69 | 9.252 | — | — |
| Axis of trunnions from face of breech. | " | 23.23 | 24.80 | — | — |
| †Radius of sights | " | 37.48 | 37.2 | 17.905 | 17.905 |
| †Weight of telescope | lb. | — | — | 5½ | 5½ |
| Weight of wedge | " | 39 | 59 | — | — |
| Weight of shoulder-piece | " | 45 | 54½ | 52 | 57 |
| Total weight of gun (with shoulder-piece). | " | 514 | 803 | — | — |

† Sights are supplied with the gun for 3-pr. I. and 6-pr. I.
 " " " " " mounting for 3-pr. I* and 6-pr. I*.

TABLE SHOWING CONTENTS OF BOX, SPARE PARTS AND IMPLEMENTS, MARK II., 3- AND 6-PR. Q.F. HOTCHKISS.

| Article. | 6-pr. | 3-pr. |
|----------------------------|-------|-------|
| Brush, sponge, without rod | 1 | 1 |
| Brushes, plate, wedge | 2 | 2 |
| Can, oil | 1 | 1 |
| Driver, screw | 1 | 1 |
| Extractor | 1 | 1 |
| Extractor, hand | 1 | 1 |
| Gauge, main spring | 1 | 1 |

| Article. | 6-pr. | 3-pr. |
|---|-------|-------|
| Hammer, firing, with firing pin | 1 | 1 |
| Pins, firing | 6 | 6 |
| Screw, pivot, trigger | 1 | 1 |
| Screw, set, cradle handle | 1 | 1 |
| Screw, stop wedge | 1 | 1 |
| Screws, fixing, trigger guard or bracket, trigger piece | 3 | 3 |
| Sights, fore | 1 | 1 |
| Sights, tangent | 1 | 1 |
| Spring, crank handle and screw | 1 | 1 |
| Spring, trigger, retaining, with two fixing screws | 1 | 1 |
| Springs, main | 4 | 4 |
| Spring, trigger sear | 2 | 2 |
| Tommy | 1 | 1 |
| Trigger sear | 1 | 1 |
| Plate wedge | — | 1 |
| Screws, fixing, plate-wedge | — | 2 |

TABLES OF WEIGHTS AND MEASUREMENTS.

MOUNTINGS AND ACCESSORIES.

| | | 3-pr. I. | 6-pr. I. | 3-pr. I*. | 6-pr. I*. |
|---|------|----------|----------|-----------|-----------|
| Weight of pivot for fixed stand | lbs. | 150 | 242 | — | — |
| Weight of fixed stand | " | 651 | 832 | — | — |
| Total weight of gun and mounting (without shield). | " | 1,307 | 1,877 | — | — |
| Weight of recoil carriage (without shield or base plate). | " | 448 | 560 | — | — |
| Weight of do., lightened and built up. | " | 378 | 491 | 427 | 472 |
| Weight of base plate | " | 84 | 84 | — | — |
| Weight of do., lightened | " | 54 | 56 | 56 | 56 |
| Weight of accessories for mounting. | " | 51 | 58 | — | — |
| Mean height of trunnions above deck. | ft. | 4.43 | 4.43 | — | — |
| Weight of chest with spare parts. | lbs. | 24 | 30 | — | — |
| Weight of loaded ammunition box. | " | 128 | 128 | — | — |
| Number of rounds in box | — | 16 | 11 | — | — |
| Weight of sight brackets | lbs. | — | — | 41 | 41 |
| Total weight of mounting, cradle and sights (but not including gun, holding down ring, shield and telescope). | " | 448 | 532 | 570 | 628 |

HOTCHKISS QUICK FIRING GUN.

BODY OF GUN.

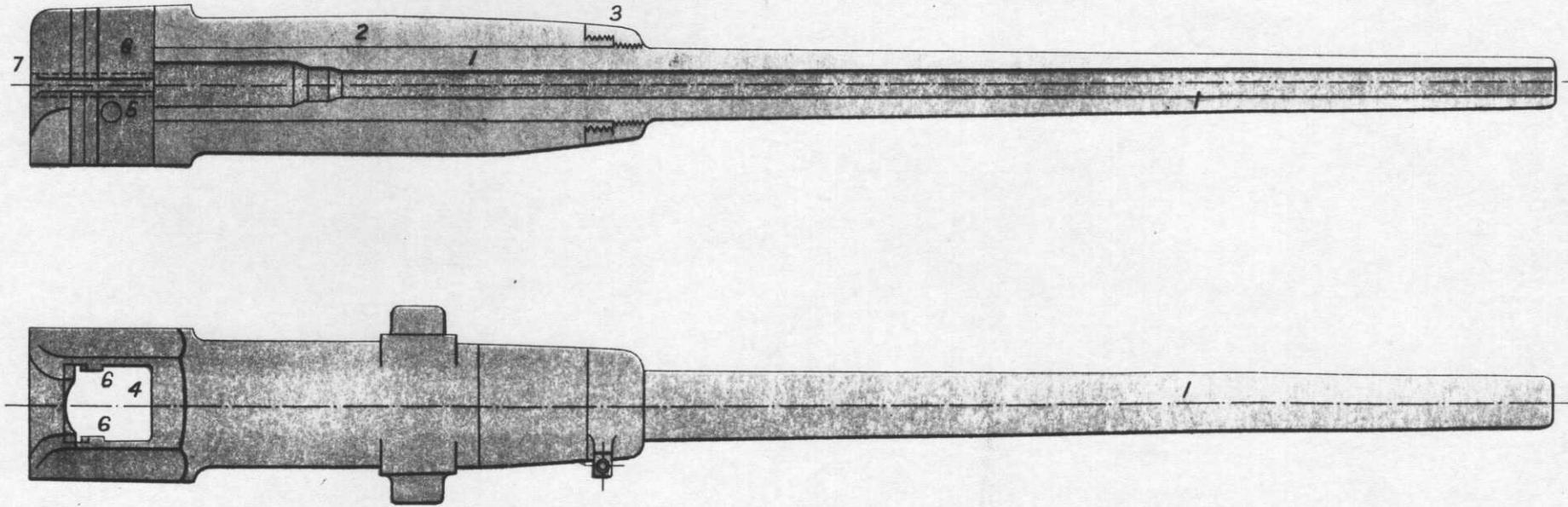

HOTCHKISS QUICK FIRING GUN.

BREECH ACTION.

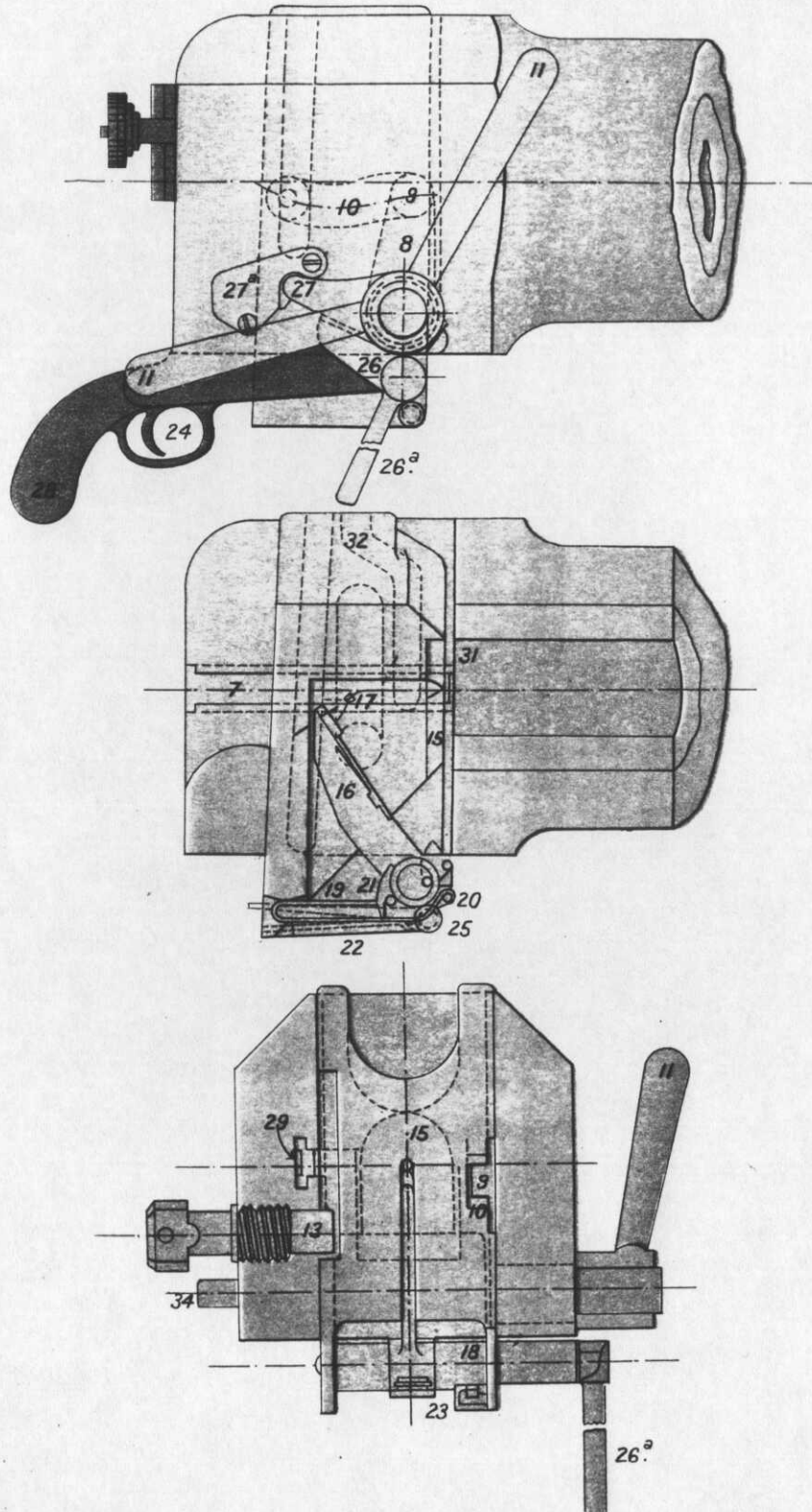

HOTCHKISS QUICK FIRING GUN.

ACCESSORIES.

Stock and Sights

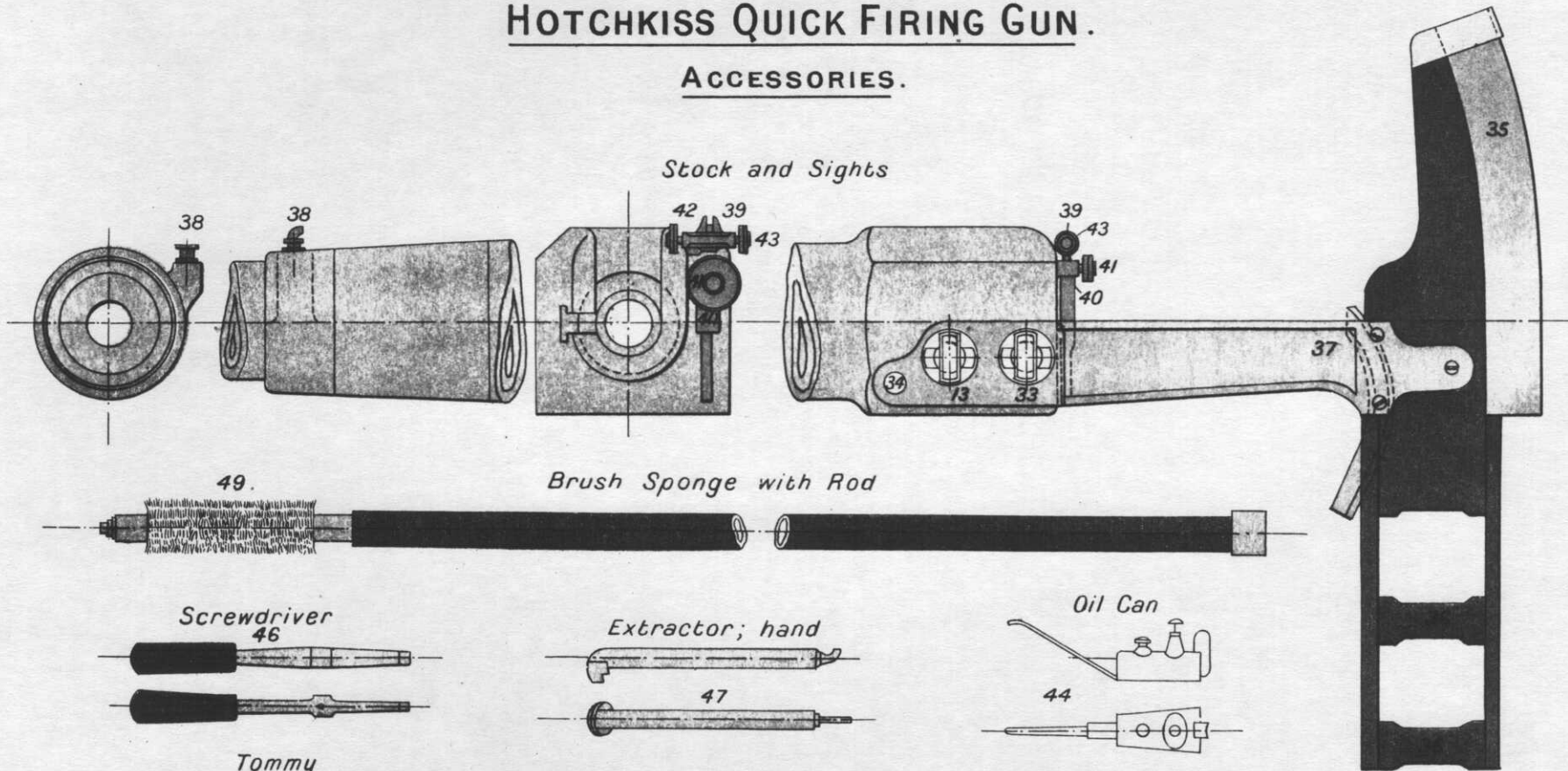

HOTCHKISS QUICK FIRING GUNS.

FIG. 1.
TRIGGER SEAR SPRING.

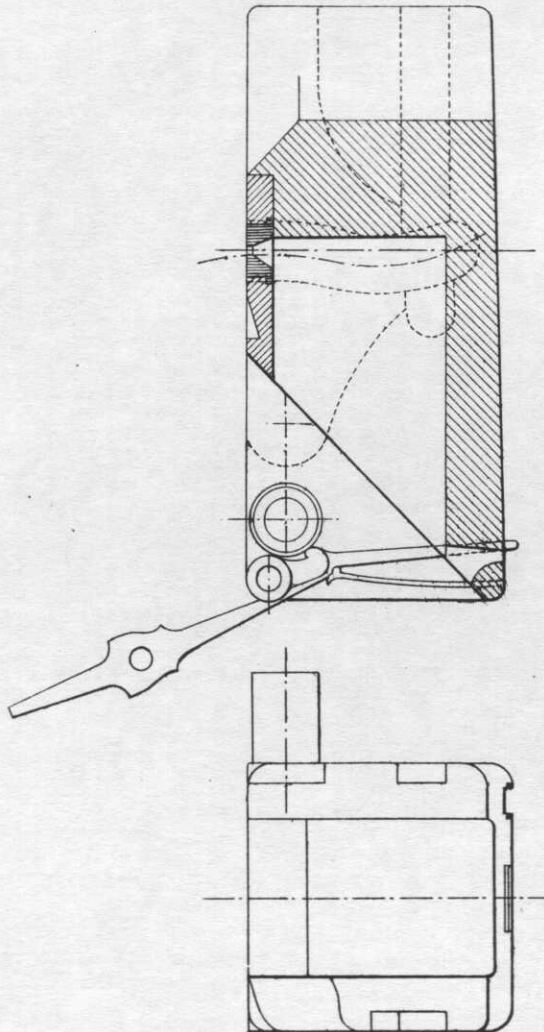
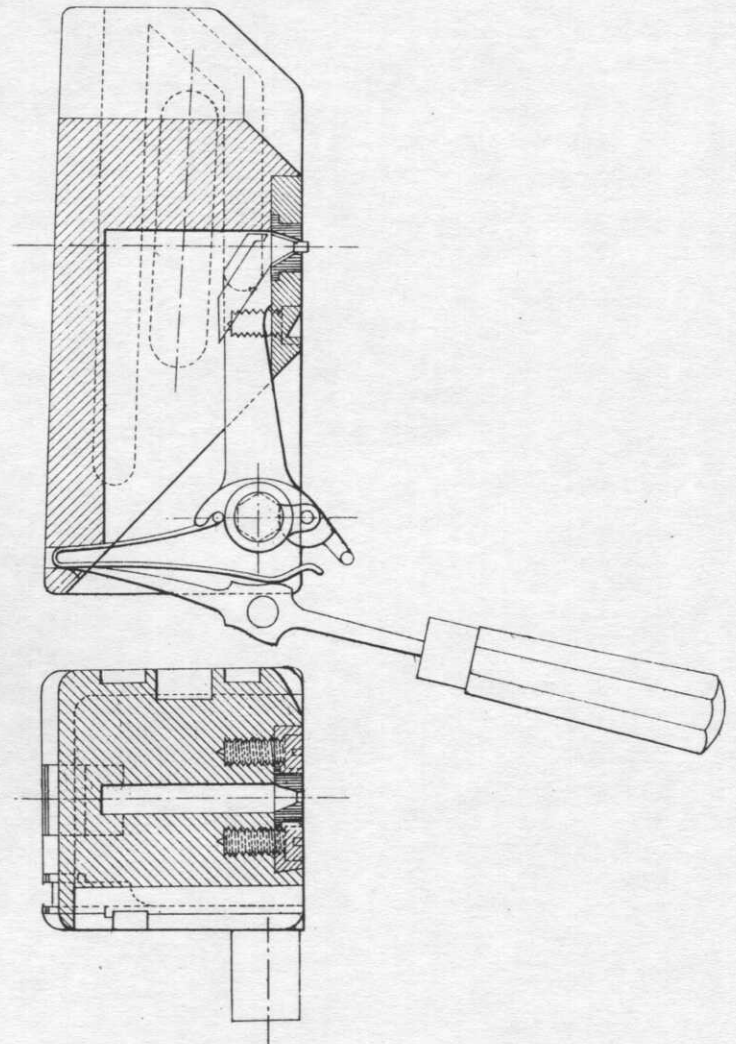
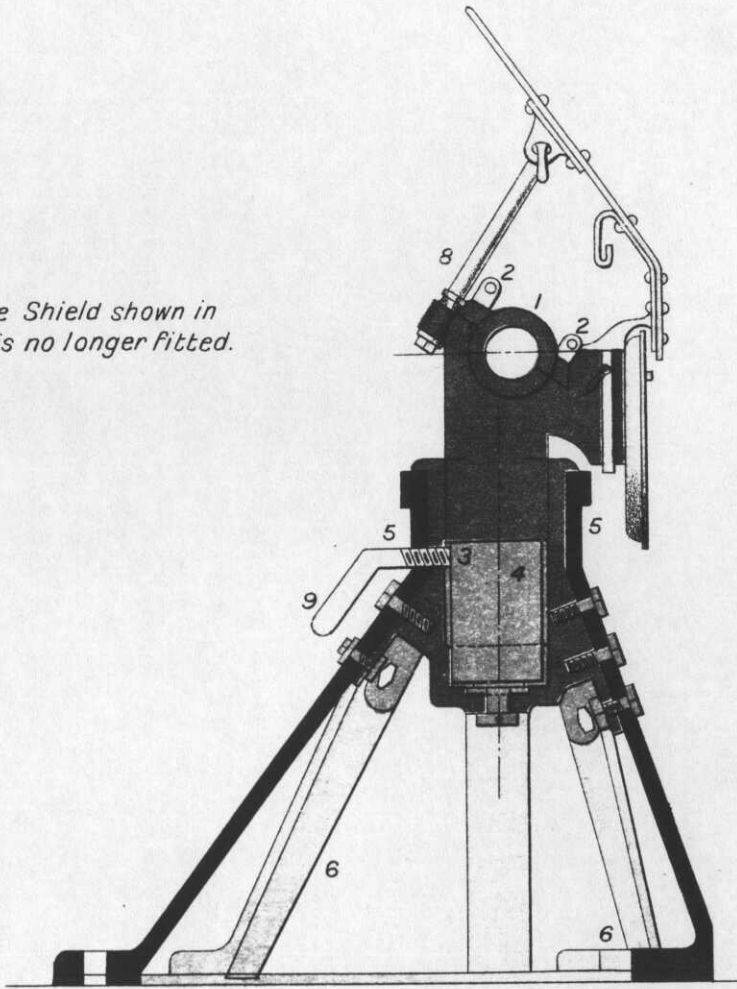

FIG. 2.
MAIN SPRING.



NON-RECOIL MOUNTING

Note: The Shield shown in Section is no longer fitted.



SECTION THROUGH A. B.

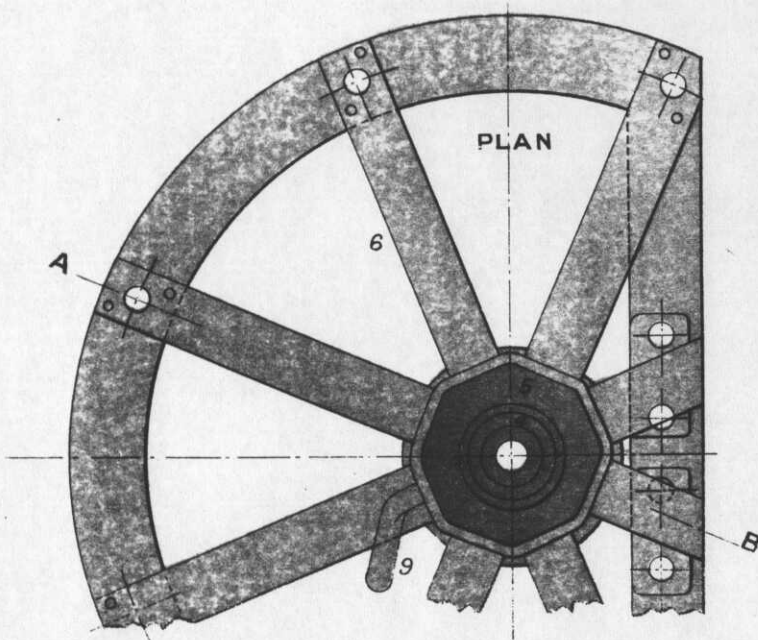

RECOIL MOUNTING MARK I FOR 3 PR Q.F. GUN.

SCALE $\frac{1}{10}$ "

FIG. 1
ELEVATION

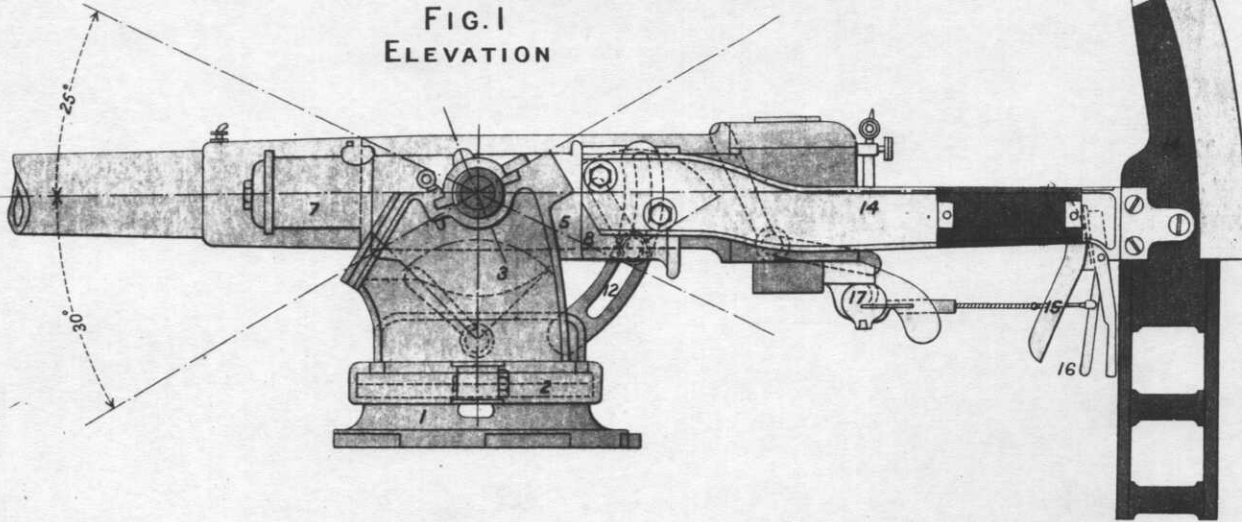
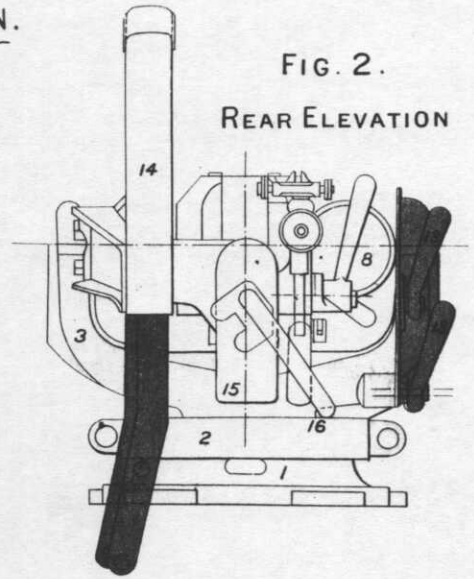

FIG. 2.
REAR ELEVATION



SECTION THROUGH CYLINDERS.

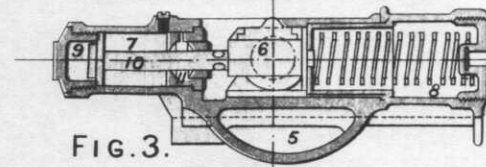

FIG. 3.

SECTION THROUGH TRUNNIONS

FIG. 4.

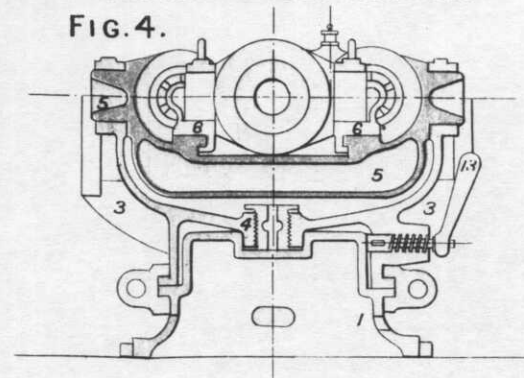
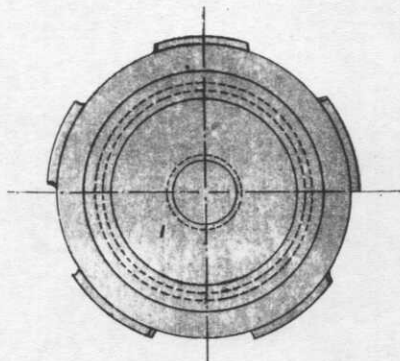
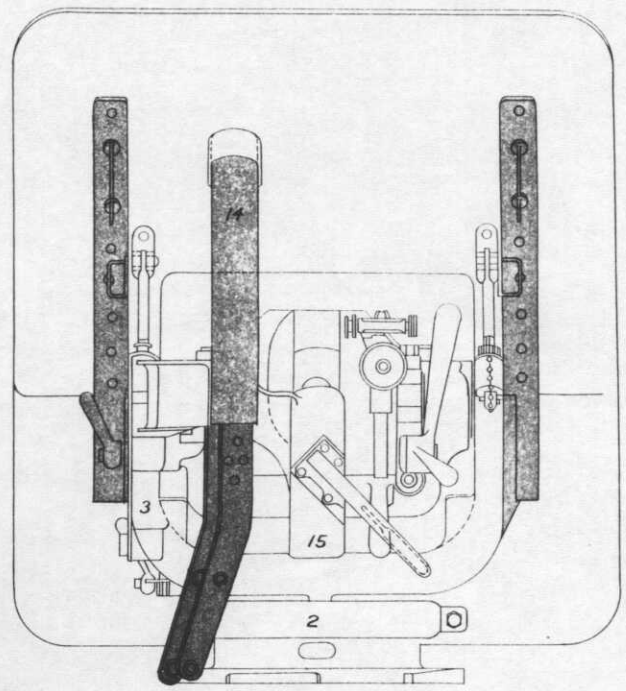

FIG. 5.



PLAN OF BASE PLATE

FIG. 2.



REAR ELEVATION

FIG. 1

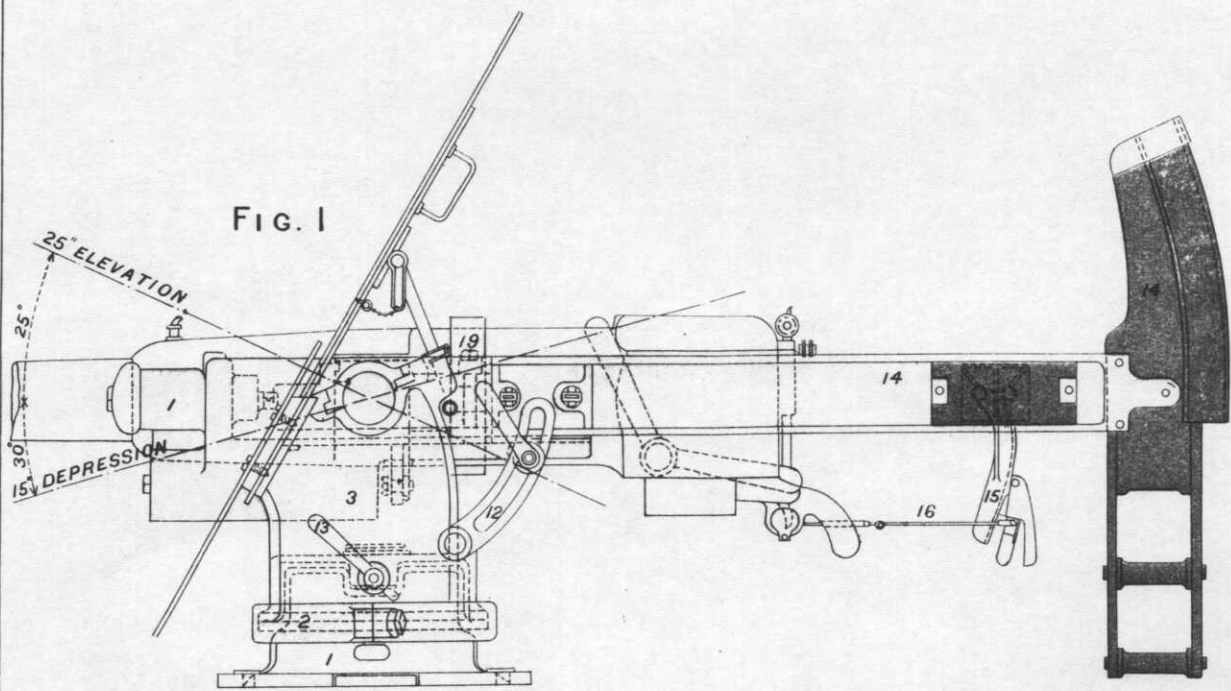

ELEVATION

RECOIL MOUNTING MARK I FOR 6 PR Q.F. GUN

SCALE, 1/10"

FIG. 3.

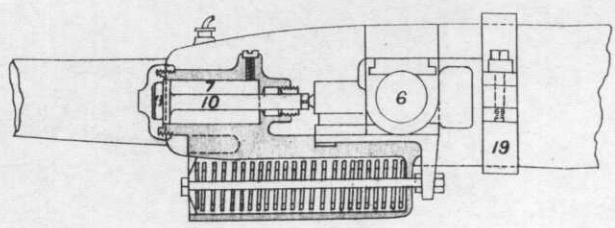

SECTION THROUGH CYLINDERS.

FIG. 4.

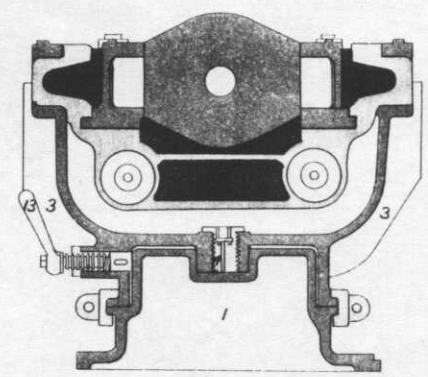

SECTION THROUGH TRUNNION

FIG 5

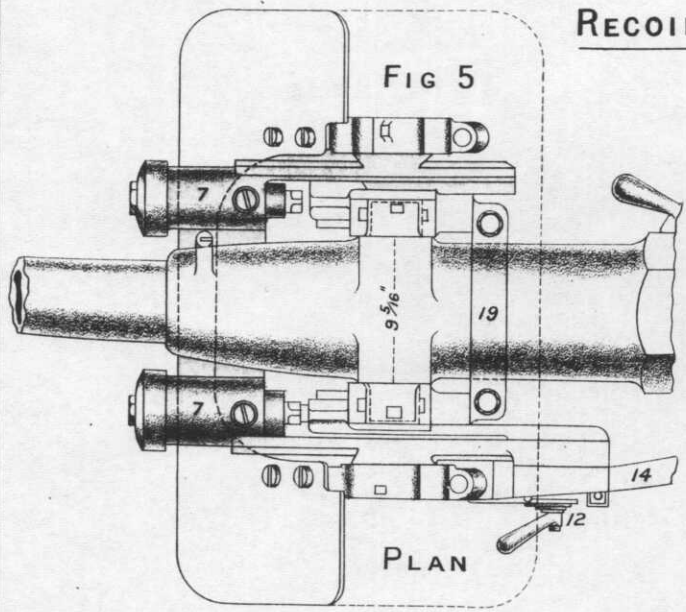

PLAN

Note: The Shields shown in Figs. 1, 2, & 5 are no longer fitted.

RECOIL MOUNTING MARK I* FOR 3 P^R Q.F. GUN.

FIG. 1.
PLAN.

SCALE 1/10"

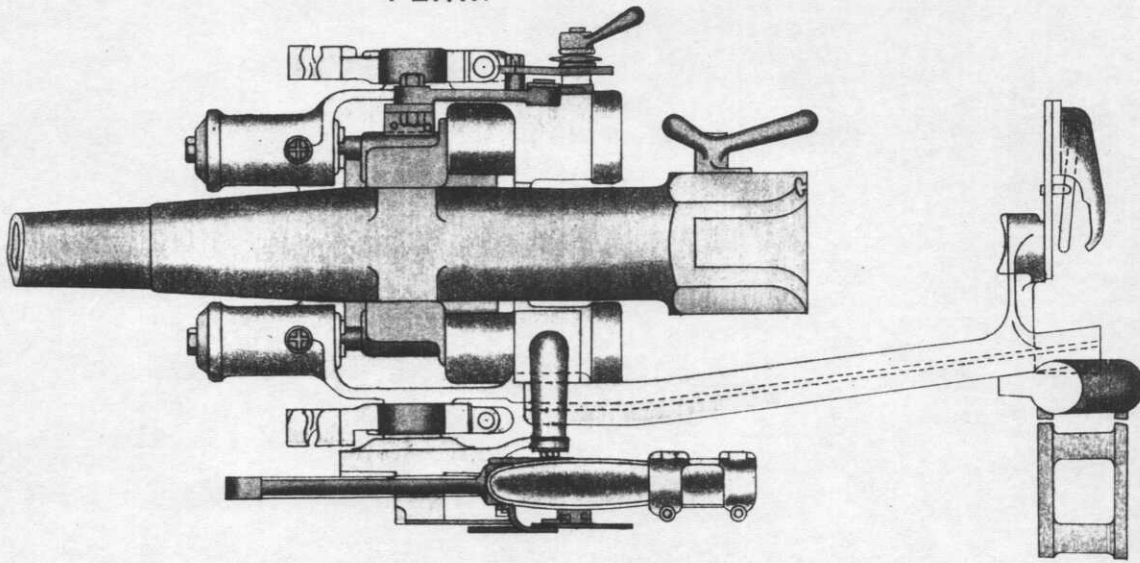

FIG. 3.
REAR ELEVATION.

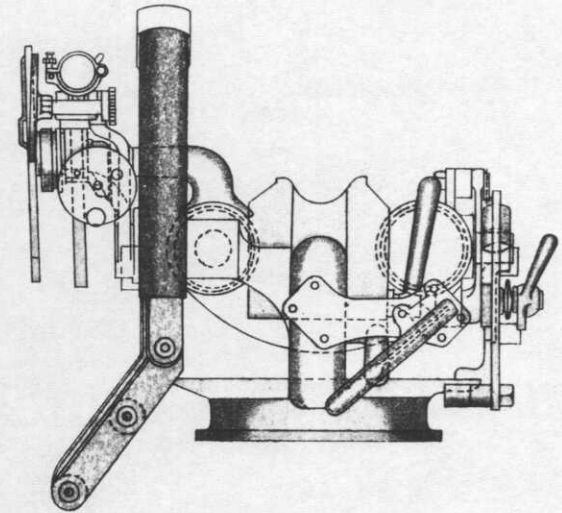

FIG. 2.
ELEVATION.

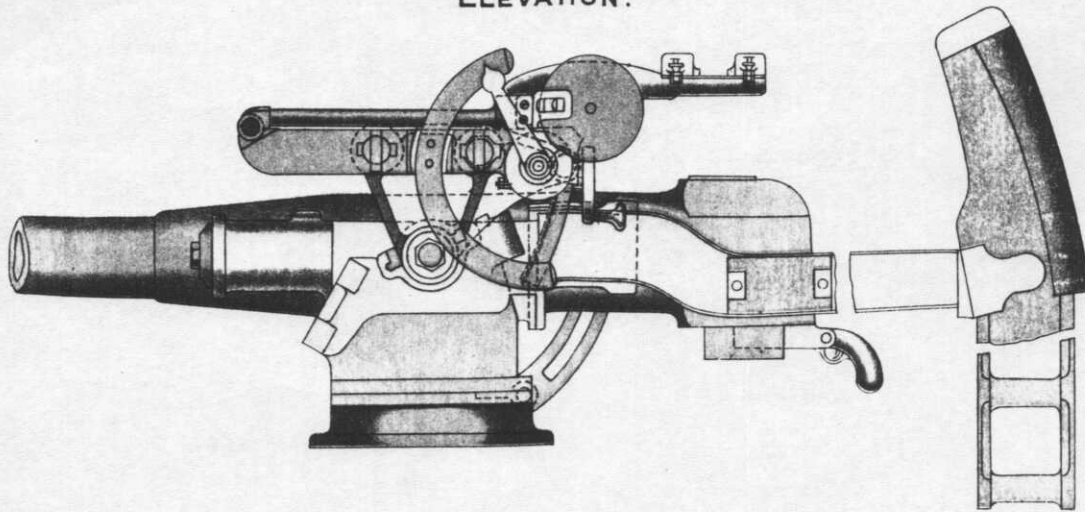
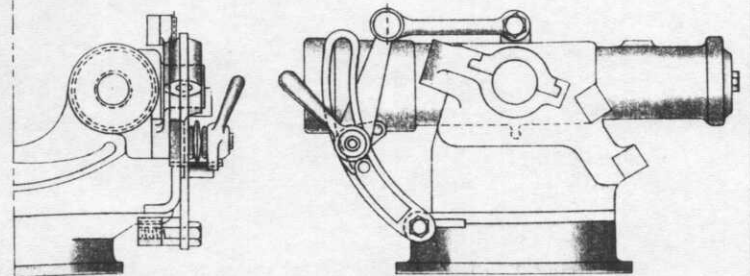

FIG. 4. ELEVATING CLAMP.

REAR ELEVATION.

ELEVATION.



MARK I * 6 P^R. MOUNTING CONVERTED FOR HIGH ANGLE FIRE.

Scale $\frac{1}{10}$

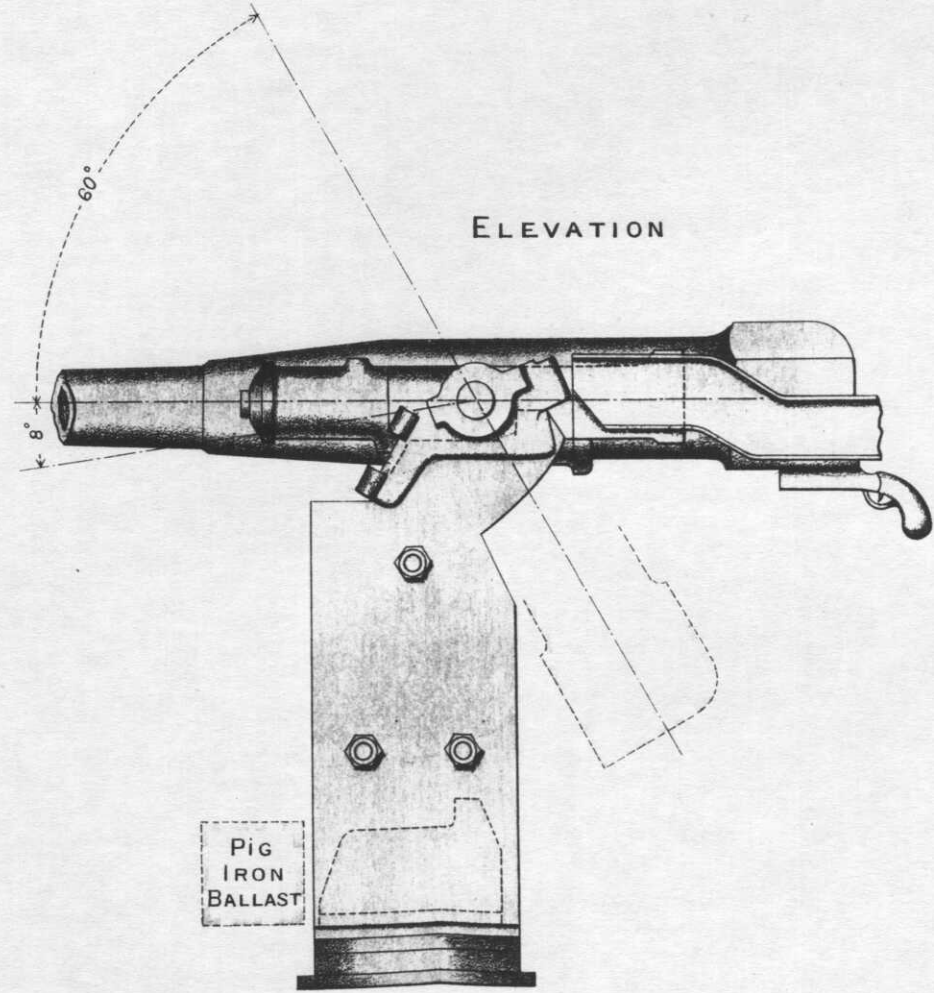

REAR ELEVATION

